

# Assembly Instructions - External Wall Plate

Models: WSP 716-GS, WSP 716-GB,  
WSP 724-GS, WSP 724-GB

**IMPORTANT!** Read entire instruction sheet before you start installation and assembly.

**MAXIMUM LOAD CAPACITY:**  
200 lb (91 kg)

## ⚠ WARNING

- Wall or mounting structure must be capable of supporting a minimum static load of 600 lb (272 kg).

**WSP 716-GS, and WSP 716-GB** for studs on 16" (406 mm) centers, contains four cable management ports.

**WSP 724-GS, and WSP 724-GB** for studs on 16", 20" and 24" (406 mm, 508 mm, 610 mm) centers, contains four cable management ports.

### PARTS LIST

MODEL #	PARTS LIST		PART #	QTY.	DESCRIPTION
	WSP 724-GB	WSP 716-GB			
✓	✓		A 024-P1043	1	wall plate 16" centers
		✓	024-P1042		wall plate 24" centers
✓	✓		B 510-9108	10	1/4-20 x 1/2" phillips screw
✓	✓		C 520-9521	12	1/4-20 x 2 1/2" phillips screw
✓	✓		D 560-9708	12	toggler
✓	✓		E 540-1063	22	washer

### PARTS LIST

MODEL #	PARTS LIST		PART #	QTY.	DESCRIPTION
	WSP 724-GS	WSP 716-GS			
✓	✓		A 024-C4043	1	wall plate 16" centers
		✓	024-C4042		wall plate 24" centers
✓	✓		B 520-9511	10	1/4-20 x 1/2" phillips screw
✓	✓		C 520-9522	12	1/4-20 x 2 1/2" phillips screw
✓	✓		D 560-9708	12	toggler
✓	✓		E 540-2056	22	washer

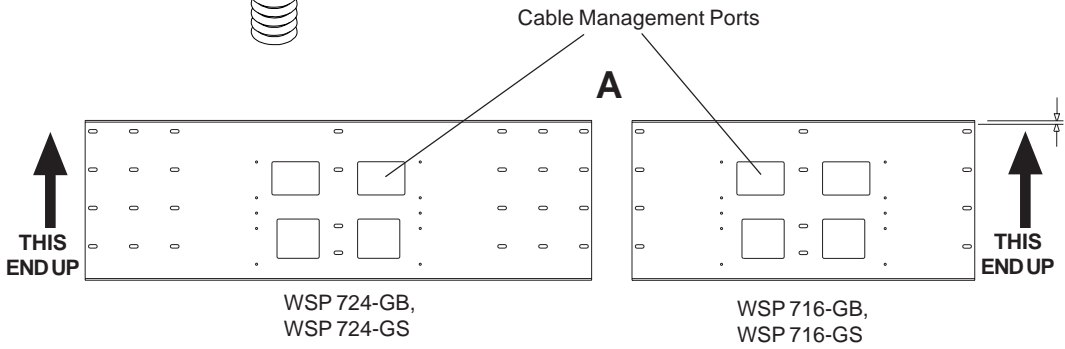
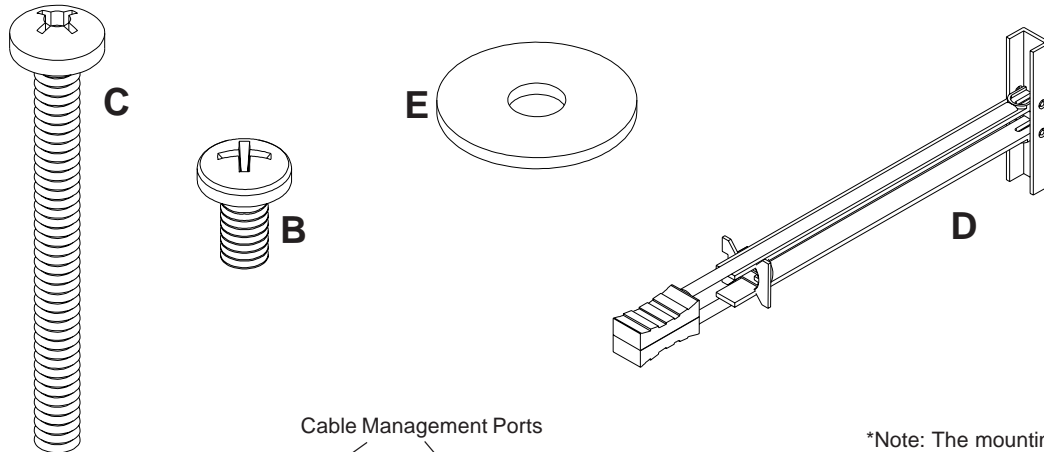

\*Note: The mounting hole which is closest to the lip of the plate indicates the up position.

**Note:** Wall plate may appear slightly different than illustrated.

- 1** Wall plate (A) can be mounted to three studs that are 16" apart on center for WSP 716 models and 16", 20" or 24" on center for WSP 724 models. Use a stud finder to locate the edges of the studs. Use of an edge-to-edge stud finder is highly recommended.

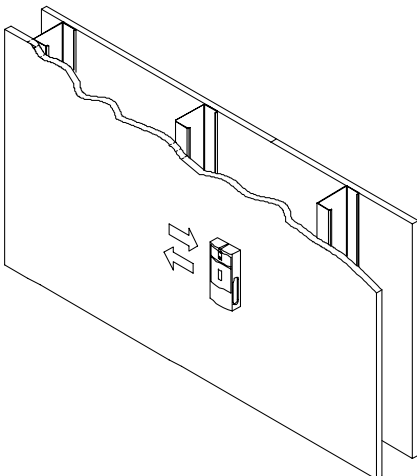

- 2** Based on their edges, draw a vertical line down each stud's center. Place wall plate on wall as a template. Level plate, and mark the center of the twelve mounting holes. Make sure that the mounting holes are on the stud centerlines. Drill twelve 1/2" holes through drywall and metal studs. **Note:** It may be necessary to drill 5/32" pilot holes prior to drilling 1/2" holes.

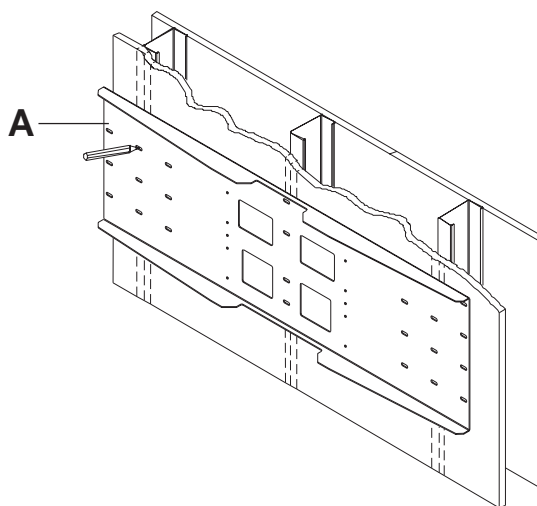
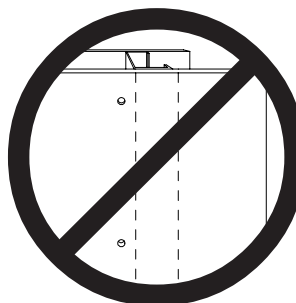

figure 1

## ⚠ WARNING

- Product must be mounted through drywall that has a minimum thickness of 1/2" and into metal studs, 26 gauge or heavier.
- Make sure that togglers are anchored into the center of the studs as shown in figure 1. The use of an "edge to edge" stud finder is highly recommended.



**3** Drill 1/2" (13mm) dia. holes through drywall and studs at locations corresponding to wall plate. Insert togglers (D) as shown below...

**3-1** Pivot end of toggler (D).

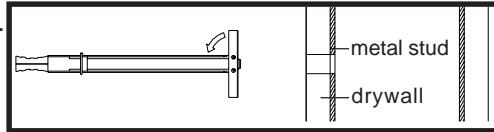

**3-2** Push into hole.

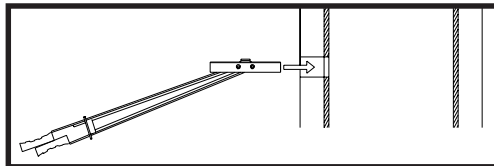

**3-3** Rotate toggler (D) clockwise to wedge it against inside walls of metal stud.

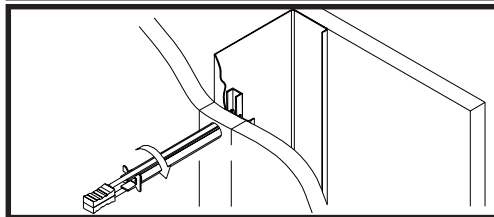

**3-4** Slide plastic cap forward while pulling back firmly on ring.

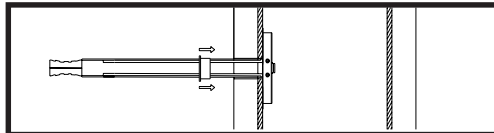

**3-5** Break off excess.

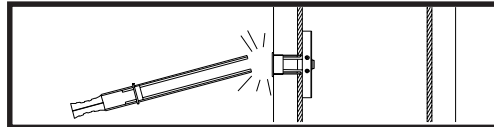

**3-6** Align wall plate with hole in wall and fasten using 1/4-20 x 2 1/2" screw (C).

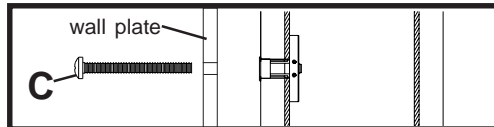

**4** Fasten wall plate to wall using twelve 1/4-20 x 2 1/2" phillips screws (**C**) and twelve washers (**E**) as shown below.

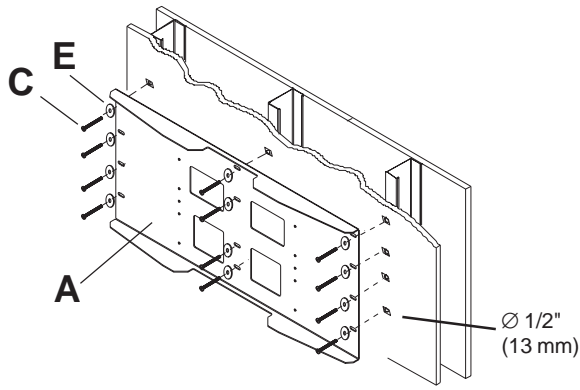

**WSP 716**

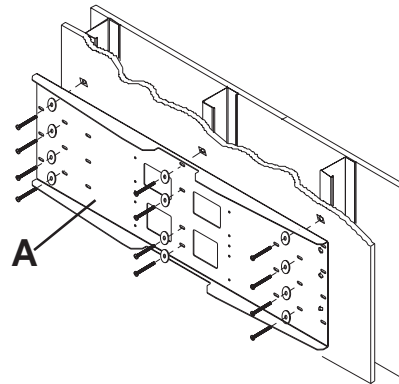

**WSP 724**

**5** See below for proper holes to attach mount to wall plate. Attach wall mount to wall plate (**A**) using 1/4-20 x 1/2" screws (**B**) and washers (**E**) as indicated below.

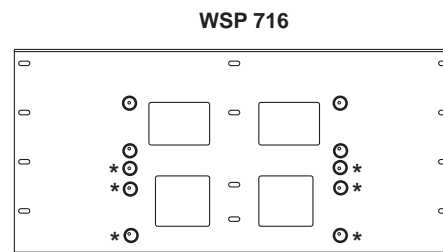
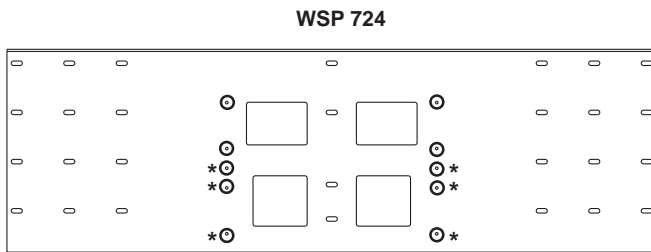

PLA 50 = \*

PLA 60, PLAV 60, PLAV 70 = O