

MXV Dual Monitor Arm with C-Clamp (top mount)

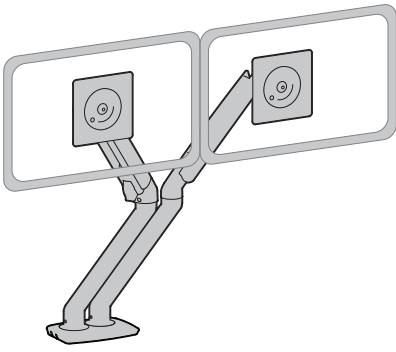

Dimensions

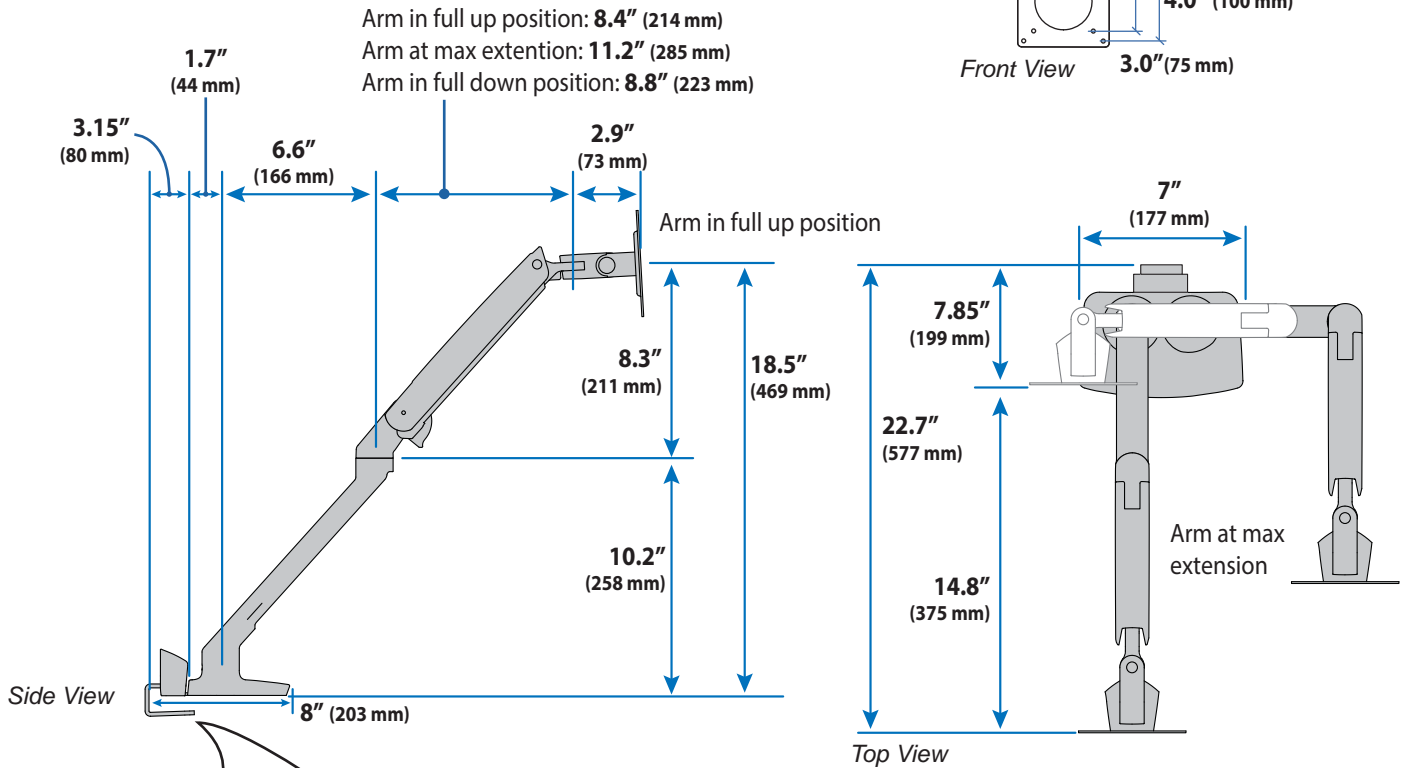

Monitor Interface Bracket

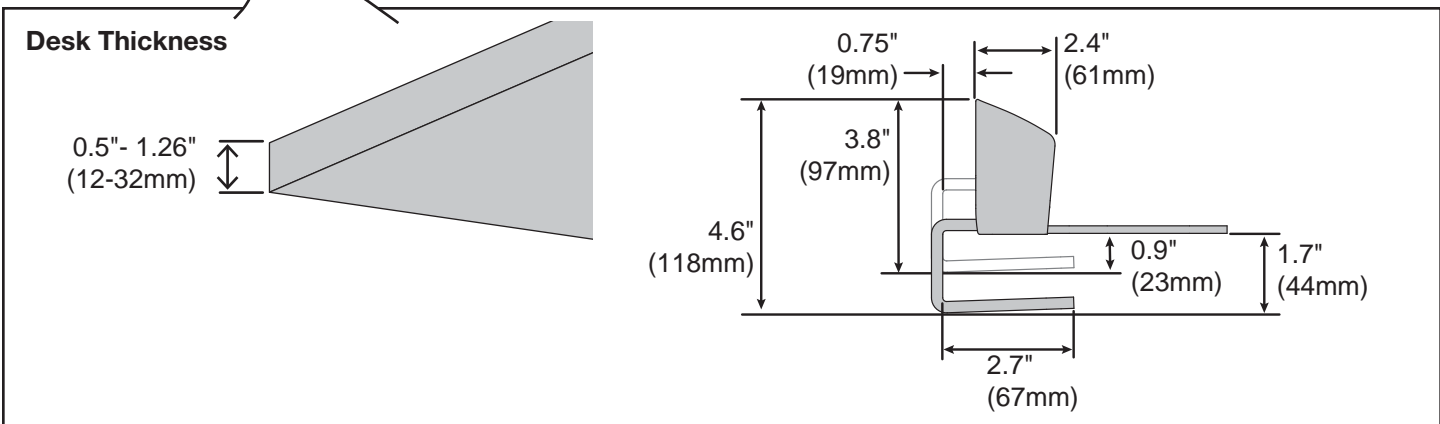
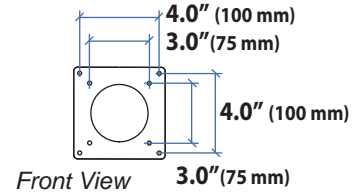

© 2017 Ergotron, Inc. rev. 05/04/2017 DIM-MXVdual-TopCclamp Content is subject to change without notification

Americas Sales and Corporate Headquarters

St. Paul, MN USA
 (800) 888-8458
 +1-651-681-7600
 www.ergotron.com
 sales@ergotron.com

EMEA Sales

Amersfoort, The Netherlands
 +31 33 45 45 600
 www.ergotron.com
 info.eu@ergotron.com

APAC Sales

Tokyo, Japan
 www.ergotron.com
 apaccustomerservice@ergotron.com

Worldwide OEM Sales

www.ergotron.com
 info.oem@ergotron.com



MXV Dual Monitor Arm with C-Clamp (top mount)

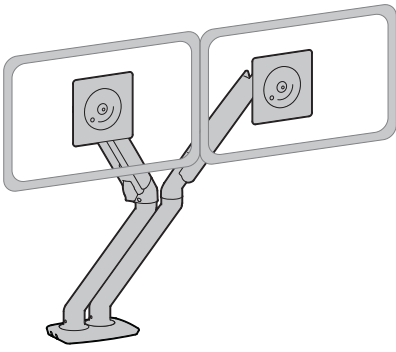

Dimensions

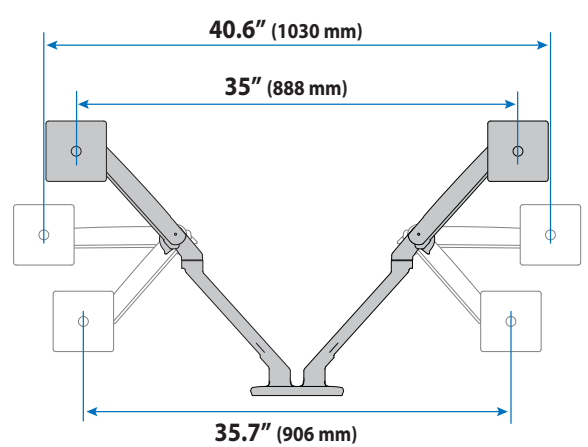
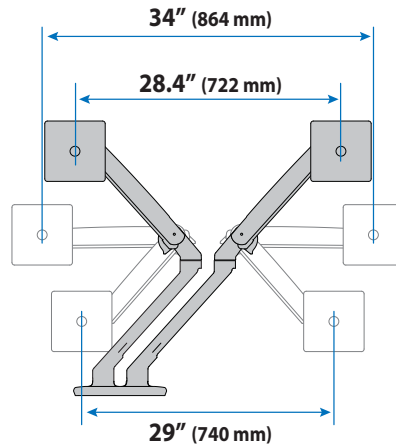
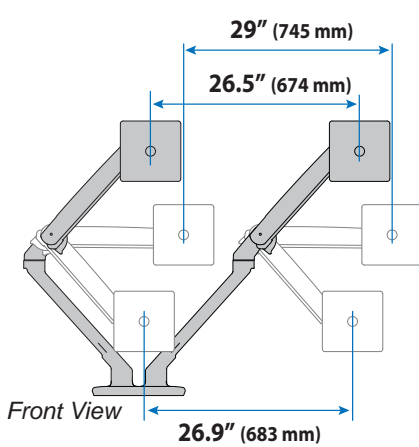
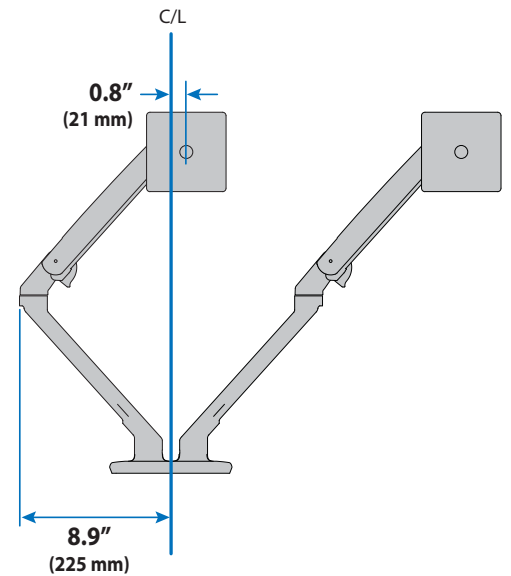
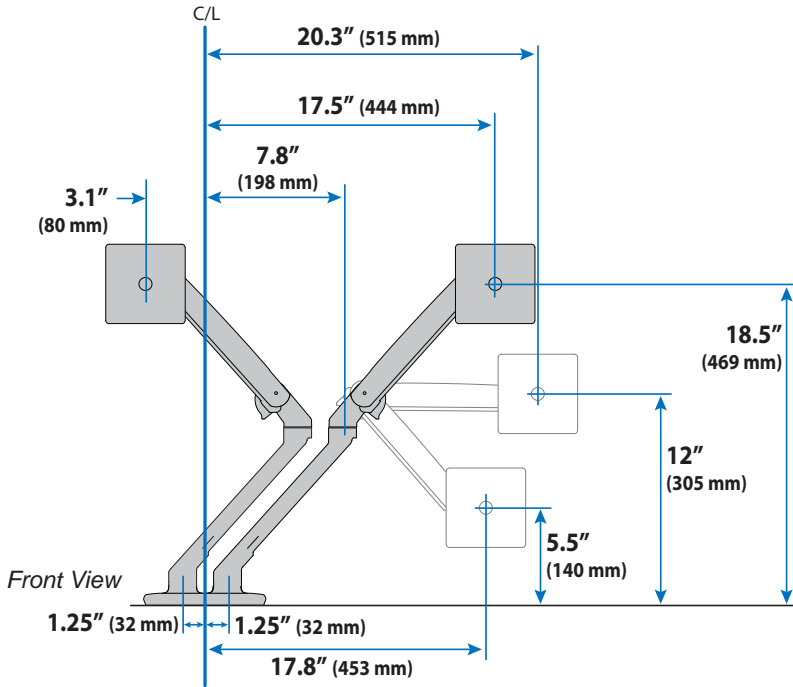

© 2017 Ergotron, Inc. rev. 05/04/2017 DIM-MXVdual-TopCclamp Content is subject to change without notification

Americas Sales and Corporate Headquarters

St. Paul, MN USA
(800) 888-8458
+1-651-681-7600
www.ergotron.com
sales@ergotron.com

EMEA Sales

Amersfoort, The Netherlands
+31 33 45 45 600
www.ergotron.com
info.eu@ergotron.com

APAC Sales

Tokyo, Japan
www.ergotron.com
apaccustomerservice@ergotron.com

Worldwide OEM Sales

www.ergotron.com
info.oem@ergotron.com



MXV Dual Monitor Arm

with C-Clamp (top mount)

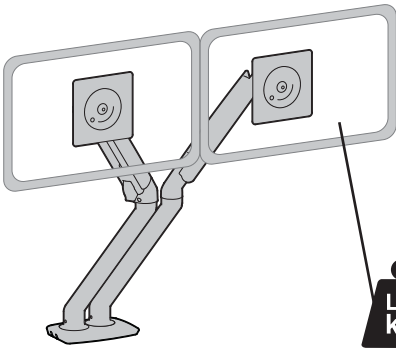

Weight Capacity per Monitor:
≤ 20 lbs. (9.1 kg)

Monitor depth greater than 2.5" (64 mm) may diminish capacity.
 Call Ergotron for more information.

Range of Motion

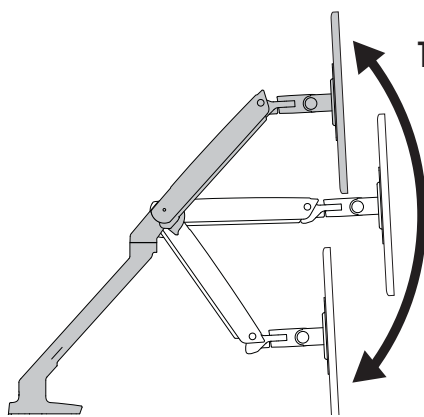

12.6" (320 mm)

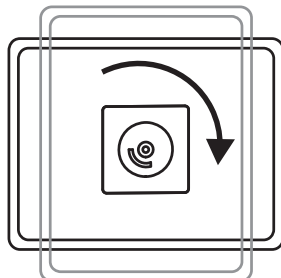
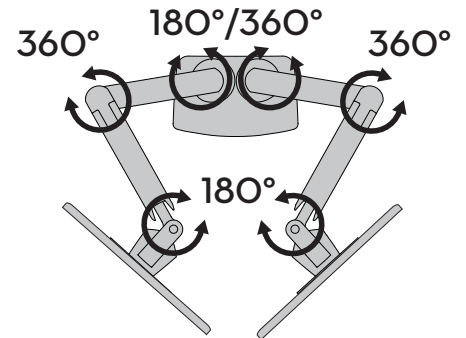
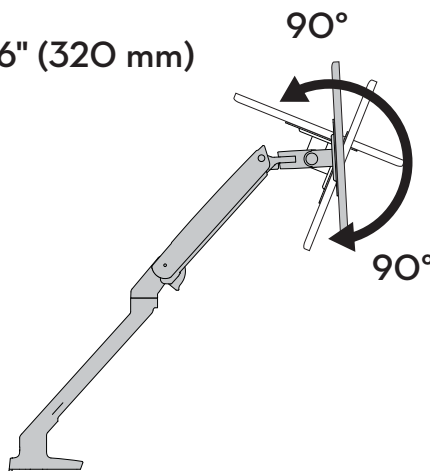

Front View

Portrait/Landscape Rotation.

Americas Sales and Corporate Headquarters

St. Paul, MN USA
 (800) 888-8458
 +1-651-681-7600
 www.ergotron.com
 sales@ergotron.com

EMEA Sales

Amersfoort, The Netherlands
 +31 33 45 45 600
 www.ergotron.com
 info.eu@ergotron.com

APAC Sales

Tokyo, Japan
 www.ergotron.com
 apaccustomerservice@ergotron.com

Worldwide OEM Sales

www.ergotron.com
 info.oem@ergotron.com