

Model 7011-8252

Specifications

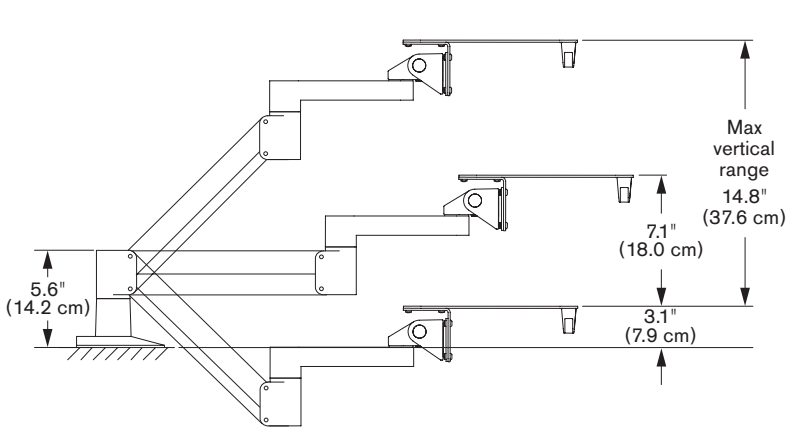

SIDE VIEW
Vertical Range

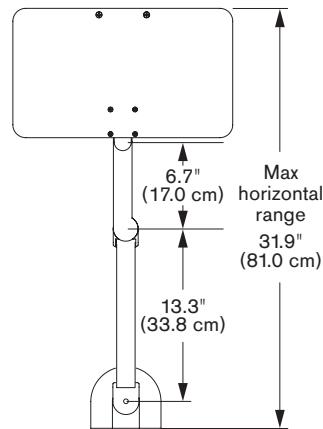

TOP VIEW
Horizontal Range

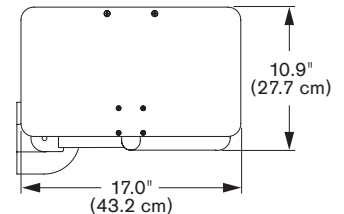

TOP VIEW
Arm Folded

CAPABILITIES

- Vertical range** 14.8" (37.6 cm) from horizontal
- Horizontal range** 31.9" (81.0 cm)
- Rotation** 360 degrees at three joints
- Notebook tray size** 17" x 10" (43.2 x 25.4 cm)
- Cable management** Cables are concealed in arm
- Mounting options** FLEXmount™, Slatwall, Wall, Thru-Desk
- Monitor weight/model number** 1 - 12 lbs (0.5 - 5.4 kg) / 7011-8252-500hy
5 - 23 lbs (2.3 - 10.4 kg) / 7011-8252-800hy

FLEXMOUNT™ CONFIGURATIONS

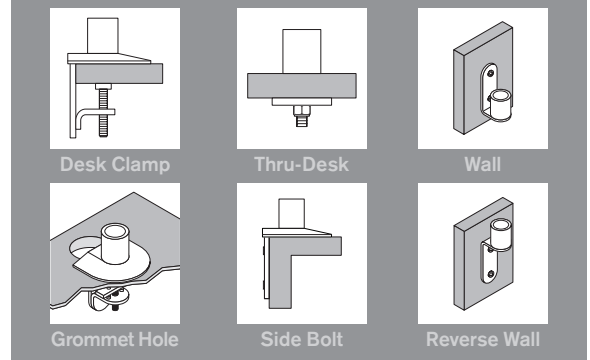

OPTIONAL ACCESSORIES

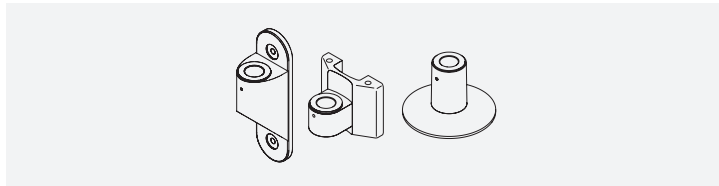

MOUNTS

Wall (8325), slatwall (8246) and thru-desk (8312).

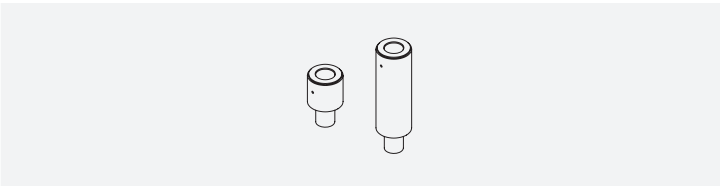

EXTENDER TUBES

Raise the height of your arm. 2" (8171-2) and 6" (8171-6) extensions available.

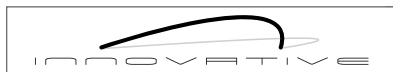

Phone: 800.524.2744 | Fax: 610.253.9521 | E-mail: sales@LCDarms.com | Web: www.LCDarms.com

This product is protected by one or more of the following U.S. Patent Nos. and other United States and foreign patents applied for: 119,345, 119,346, 1,324,842, 2,470,525, 6,076,785, 6,273,383, 6,409,134, 6,478,274, 6,499,704, 6,505,988, 6,609,691, 6,191,606, 6,719,253, 6,726,167, 6,736,364, 6,783,105, 6,854,698, 6,915,994, 6,935,883, 6,955,328, 6,983,917, 6,986,489, 7,014,157, 7,017,874, 7,048,242, 7,059,574, 7,063,296, 7,066,433, 7,066,435, 7,389,965, D435,852, D491,952, D492,893, D570,853, D575,293.