

Anthro® File-Hanging 2 Drawer Assembly Instructions



These Assembly Instructions are for the 298xx.

Before beginning assembly of your Anthro File-Hanging 2 Drawer, please take a moment to review the parts list below to verify that your shipment is complete.

Review the assembly instructions of all Anthro products you purchased and are planning to include in this installation prior to beginning this assembly.

An electric drill and 1/8" drill bit are required for this assembly.

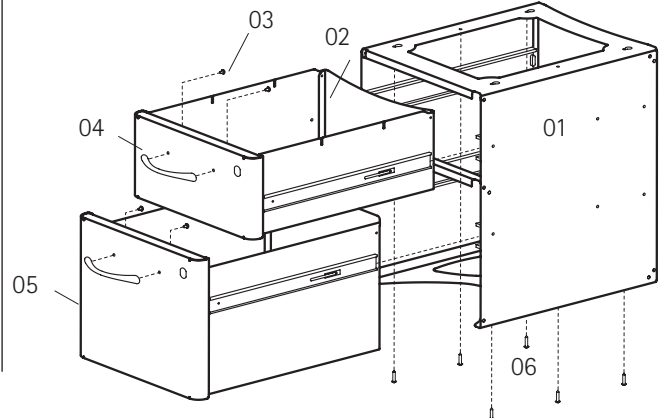

Enclosed Parts List

01- Housing Assembly	Qty. 1.....	225-5481-xx
02- 6" Hanging Drawer Body	Qty. 1.....	225-5474-xx
03- M4 x 8mm Phillips Screws	Qty. 4.....	325-A129-18-01-00
04- Drawer Pull (DP 10B)	Qty. 2.....	175-A138-10-01-03

05- 11" Hanging File Body.....	Qty. 1	225-5476-xx
06- 3/4" Wood Screws (2 extras)	Qty. 6.....	325-5106-00
Drill Template (not shown).....	Qty. 1	300-5140-00

A 5/32" Anthro Hex Driver and Phillips Screwdriver (*both not included*) will be required for this assembly.

Step 1

Pull the top drawer all the way out. Locate the drawer glides on each side of the drawer body, and then locate the lever inside each glide. Push the levers down to release the drawer body from the housing and pull the drawer body away from the housing.

Set aside the top drawer, then remove and set aside the lower drawer.

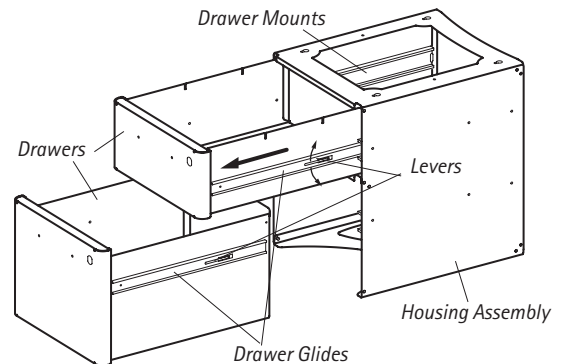

Step 2 (requires a Philips Screw Driver)

Position the drawer pulls against the front of the drawers and secure into place using the two Phillips screws.

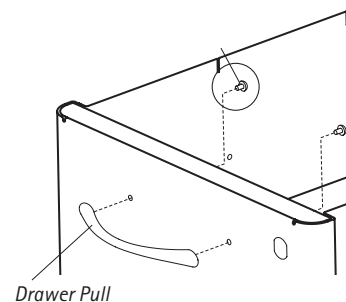

Install the Drawer Pull using the two Metric Screws.

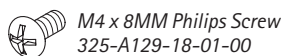

Step 3 (requires an electric drill and 1/8" drill bit)

Determine the location of your drawer unit on your assembled workstation. Locate the Drill Template. Follow its instructions to drill the holes for installing your drawer's housing assembly.

Once the holes have been drilled and the four wood screws are partially installed, align the housing assembly with the workstation so it opens to the front of the workstation and the four keyholes on the assembly line up with the wood screws. Slip the housing assembly over the wood screws (Figure 1), then slide the housing to the back of the workstation so the screws rest in the narrow end of the keyholes on the housing (Figure 2). Tighten the wood screws (Figure 3).

Install the remaining two wood screws into the center holes.

Items shown shaded are not included with this Accessory.



3/4" Wood Screw
325-5106-00



Figure 1
Insert Wood Screw
through Keyholes.



Figure 2
Push housing to the
back of the workstation



Figure 3
Fully tighten the
Wood Screws.

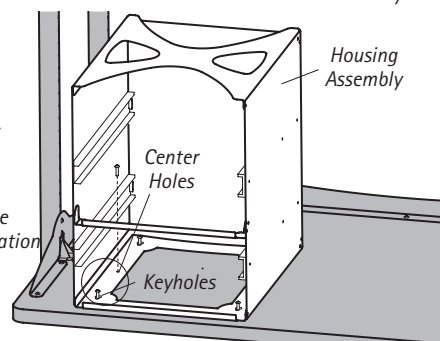

Step 4

Carefully, rotate your workstation so it's right side up.

Reinstall the drawers to the housing assembly by aligning the drawer glides (located on the drawers) with the drawer mounts (located on the housing assembly). Then firmly push the drawers all the way to the rear of your Cart.

Congratulations! Your drawer assembly is complete.

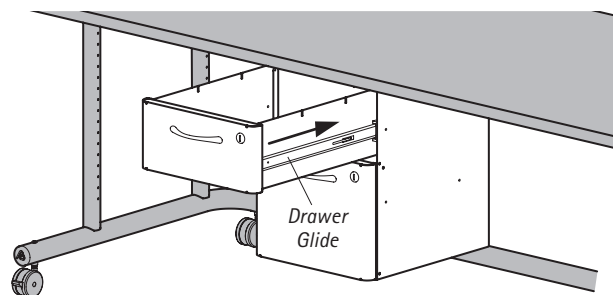

Firmly push the drawers towards the
rear of your cart.

