

# AnthroBench Leg Extensions

## Assembly Instructions



This instruction is for the 293xx and 295xx.

Before beginning assembly, review the parts listed below to verify that your shipment is complete. Items shown in gray are not included with this accessory.

Review all instructions for your assembly before you start.

SAVE THESE INSTRUCTIONS!

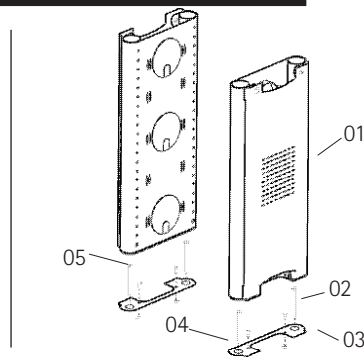

### Enclosed Parts List

01- Leg Extension	Qty. 2	(see below)
24" Leg Extension (293xx)		625-5527-xx
36" Leg Extension (295xx)		625-5528-xx
02- Base Tube Screws	Qty. 4	325-5000-00
03- Bench Extension Caps	Qty. 2	225-5376-xx
04- Keps Nuts (1/4-20)	Qty. 4	325-5130-03
05- 1/2" Button Head Screw	Qty. 4	325-5003-00

Fastener quantities listed are the minimum needed for your assembly. Your shipment may contain a few extras. A 5/32" Anthro Hex Driver, 1/4" Hex Key & 3-Way Wrench (not included) will be needed for this assembly.

Questions? 1-800-325-3841

### Step 1 (requires a 1/4" Hex Key)

Remove the Leg Covers on both Leg Assemblies. Your Bench Instructions illustrate more detail on this process if needed.

Next, remove the Leg Caps on both Leg Assemblies by removing the two Socket Cap Screws on each Leg Cap.

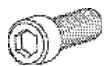

Cap Screw (not counted in the Parts List)  
325-5136-00

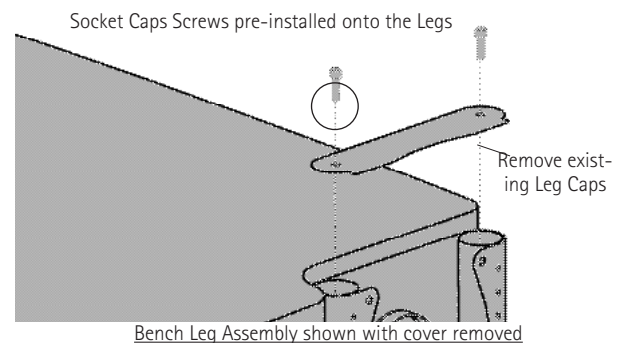

### Step 2

Orient the Bench Extension Caps on each Leg so the funnel shape is inserted down into the Leg.

Install two Base Tube Screws per Extension Cap into the Leg Tubes. **NOTE:** The Base Tube Screws will be seated below the top surface of the Extension Caps. It may be necessary to loosen the pre-installed support screws on the Leg Extension to allow the Base Tube Screws to insert freely.



Base Tube Screw  
325-5000-00

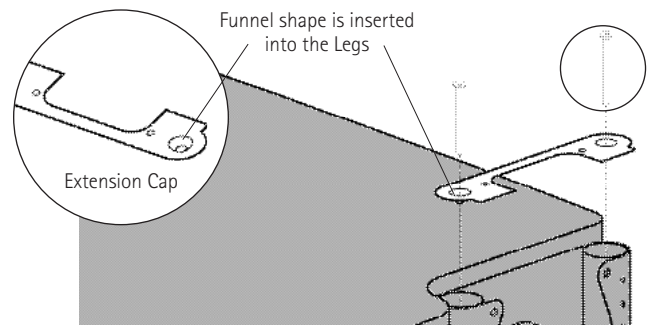

### Step 3 (requires a 3-Way Wrench)

Carefully place one Leg Extension onto a Bench Leg Assembly. Align the two holes on both the Leg Extension and Bench Leg. Insert one Button Head Screw per hole and capture it on the opposite side using a Keps Nut. Repeat procedure for remaining Leg and Leg Extension, then reinstall the Bench Leg Covers.



Button Head Screw  
325-5003-00



Keps Nut  
325-5130-03

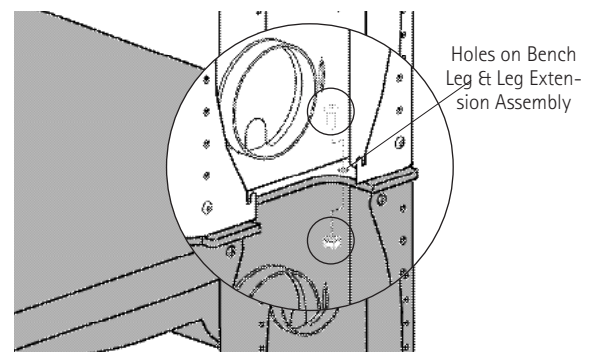

Congratulations!  
Your assembly is complete.

