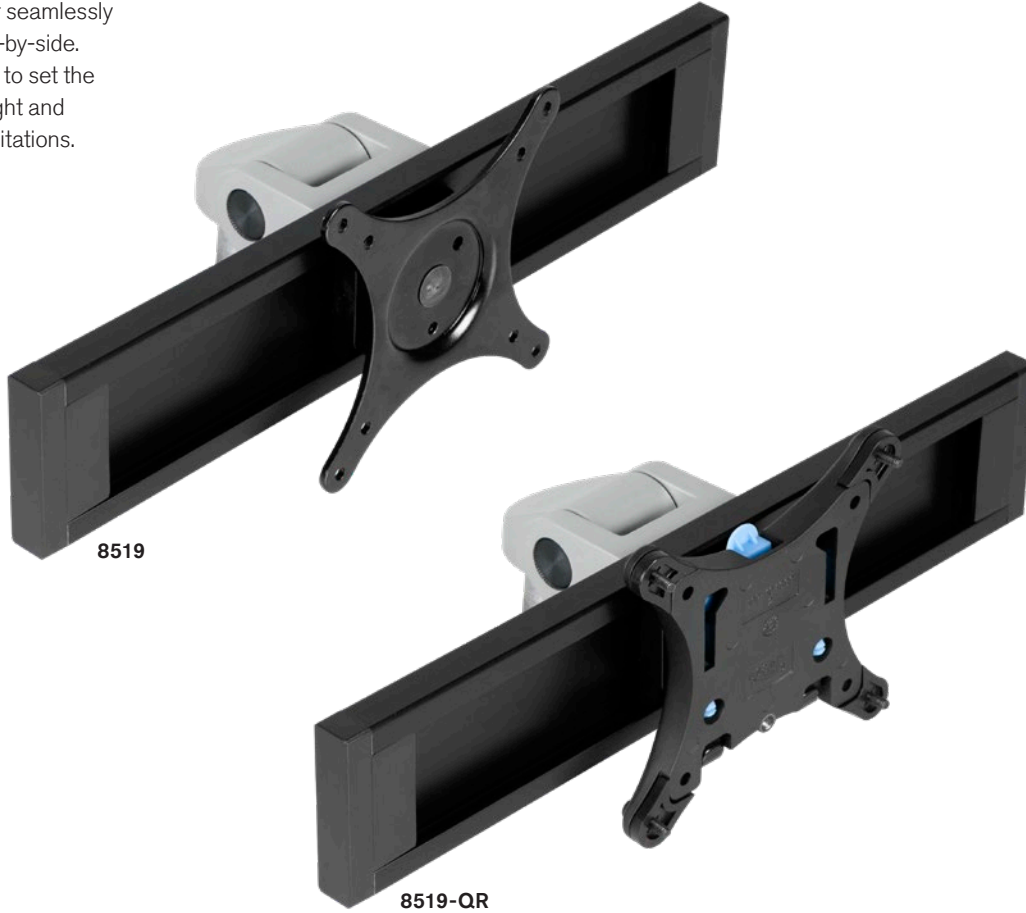

8519 / 8519-QR

Improve monitor positioning in multi-monitor configurations with our 8519 sliders. When monitor arms are adjusted forward or backward, the slider seamlessly aligns monitors size-by-side. This allows the user to set the optimal viewing height and distance without limitations.

FEATURES

- Increases the flexibility of monitor positioning.
- 9" of adjustment from left to right.
- Ideal for positioning monitors of varying sizes side-by-side.
- Allows for landscape/portrait monitor positioning.
- Monitor tilter mechanism can tilt over 200 degrees.
- Available with a quick-release VESA adapter.
- Compatible with 7000 and Staxx series monitor mounts.

AVAILABLE OPTIONS

8519	Slider with fixed 75/100mm VESA adapter
8519-QR	Slider with quick-release 75/100mm VESA adapter

FINISHES

 FLAT WHITE | color code: **248**

 SILVER | color code: **124**

 VISTA BLACK | color code: **104**



8519 CAPABILITIES

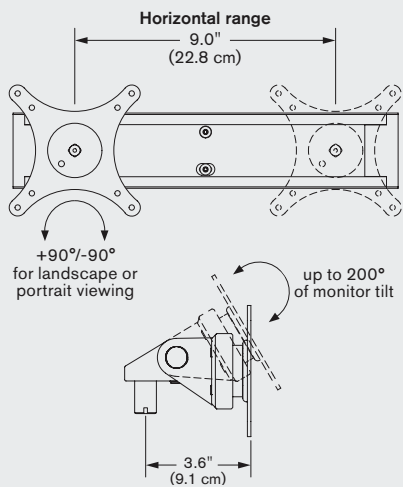

8519-QR CAPABILITIES

