

Note: Mount your adjustable keyboard arm to your worksurface and your platform to the arm using the instructions that came with that hardware.

1 Raising the Platform

- 1.1 Lift the front edge of the platform to disengage the break system.
- 1.2 Raise the Arm to your desired height.
- 1.3 Lower the front edge of the platform to lock in position.

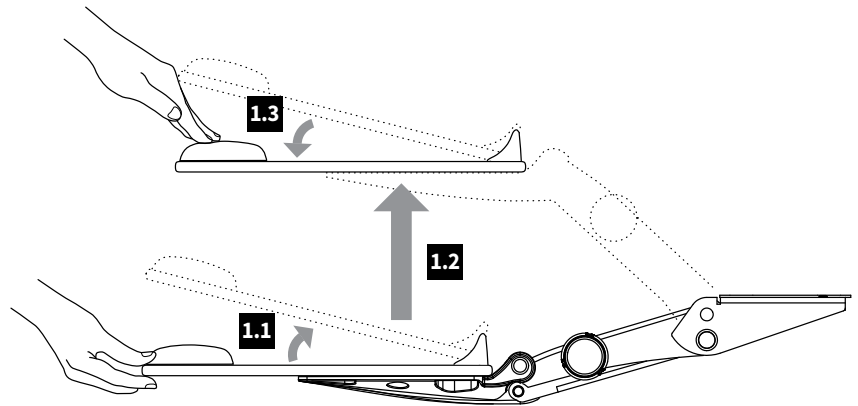

2 Lowering the Platform

- 2.1 Lift the front edge of the platform.
- 2.2 Press down on the back edge of the platform to lower to your desired height.
- 2.3 Lower the front edge of the platform to lock in position.

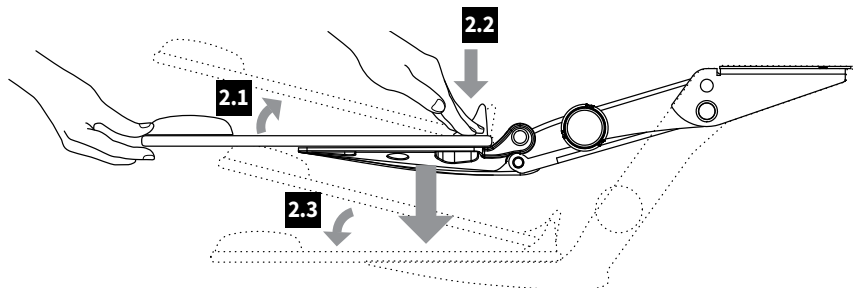

3 Adjusting Platform Tilt

- 3.1 To adjust platform toward negative tilt, turn the Tilt Knob “clockwise” until you reach a comfortable tilt angle.
- 3.2 To adjust platform toward positive tilt, turn the knob “counter-clockwise” until you reach a comfortable tilt angle.

Note: The tilt gauge located on top of the keyboard arm indicates actual tilt angle and height. A platform tilt angle between 0° to -6° is often suggested as a good base for proper wrist position.

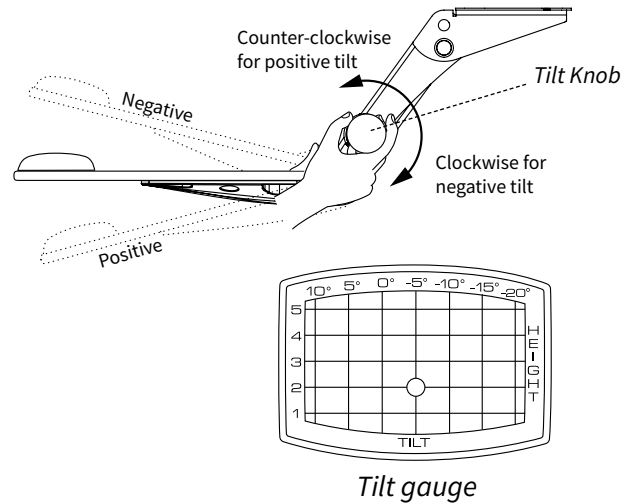

4 Arm Swivel at Track

All Workrite adjustable keyboard arms include a swivel rotation at the back of the arm at the keyboard track. To adjust swivel rotation, hold platform at both ends and rotate right or left.

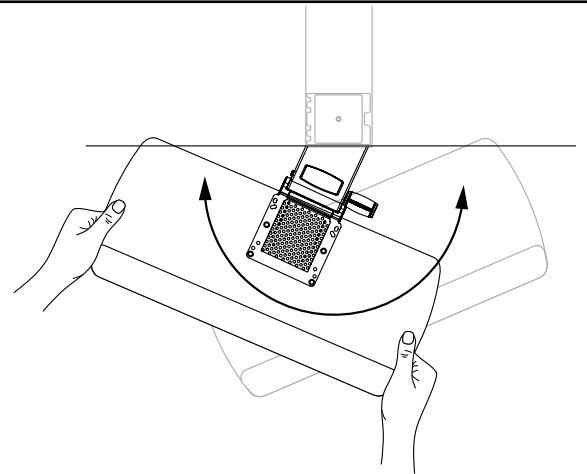

5 How to Store

Lower the keyboard platform below the worksurface and track. Push the platform to store under worksurface.

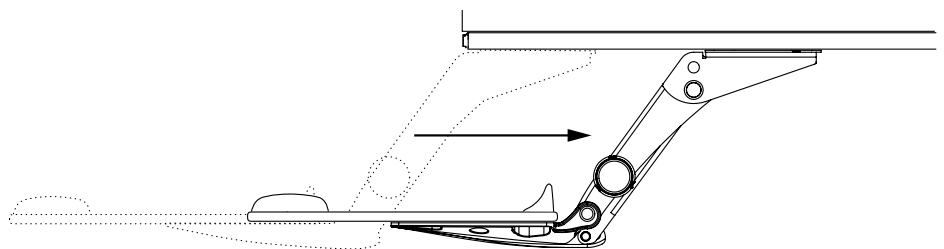

6 Consult the User Guide for your Keyboard Platform

Go to www.workriteergo.com/instructions to find your Keyboard Platform User Guide for instructions on how to set up this product for ideal ergonomic benefit.