

OV1000 | Part No. 23624

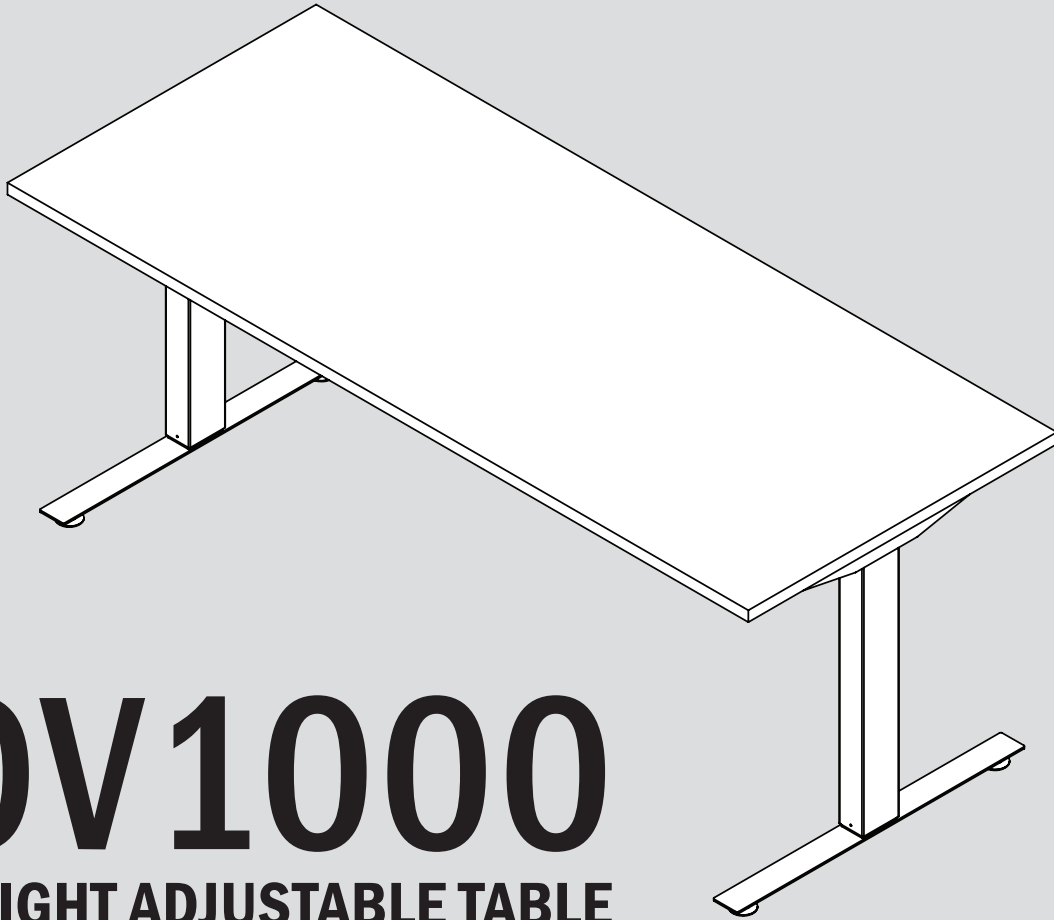

# OV1000

HEIGHT ADJUSTABLE TABLE

**USER GUIDE**

# OV1000

## HEIGHT ADJUSTABLE TABLE

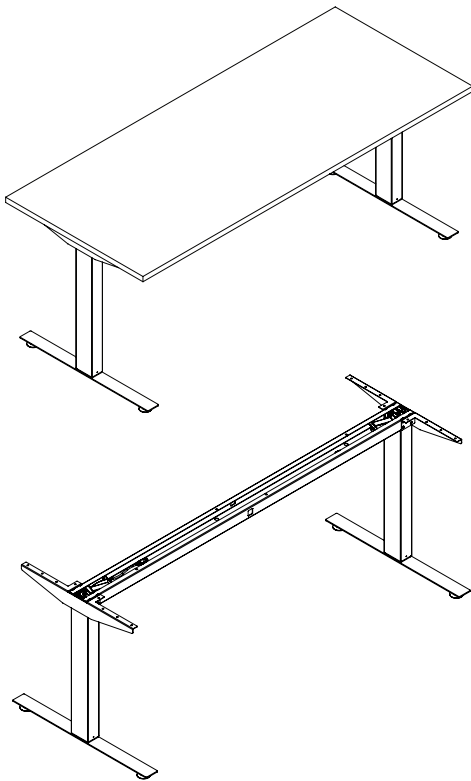

A healthier work environment starts with the option to sit or stand throughout the day. Our OV1000 table is the industry standard in height-adjustable products, and your first step towards improving the efficiency and well-being of your organization.

This kit supplies everything you need to assemble your height-adjustable table base. Just add your own work surface to personalize.

### FEATURES

- Meets BIFMA X5.5 standards
- UL 962 approved
- Adjustable frame
- Six color options
- Holds up to 200 lb. load (two-leg) or 250 lb. (three-leg)

# TABLE OF CONTENTS

<b>Parts Diagram</b>	4-8
Full Length	4
Independent	5
Independent with HAT Channel	6
Three-Leg: 90 Degree	7
Three-Leg: 120 Degree	8
<b>Safety Information</b>	9-10
<b>Assembly Instructions</b>	11-17
<b>Operation</b>	18-19
Initialization and Reset	18
Handswitch Operation	18
Programmable Handswitch Operation	18
- Change the Height Unit	19
- Adjust Height Display	19
- Save Memory Position	19
- Recall Memory Position	19
<b>Troubleshooting</b>	20-21
Unit Errors	20
Handswitch Errors	21
<b>Technical Data</b>	22
<b>Warranty</b>	23
<b>Standards &amp; Certifications</b>	23

This manual explains how this sit-stand desk is assembled, used, and maintained. All sit-stand tables are subjected to functional and quality tests before leaving our facility.

# OV1000

## PARTS DIAGRAM

### FULL LENGTH

For tables up to 84"

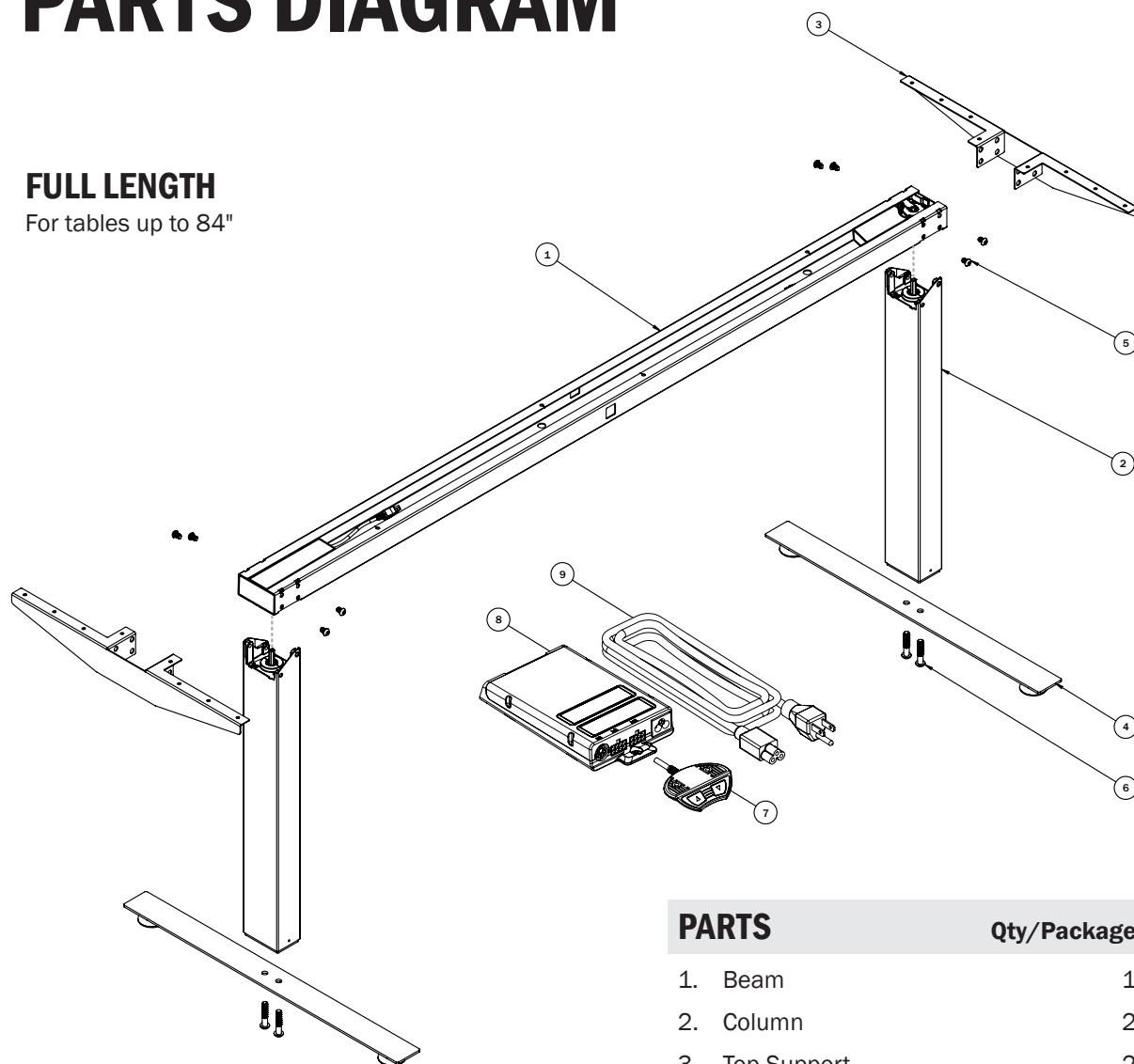

**DO NOT** remove the foam surrounding the motor.

### PARTS

### Qty/Package

1.	Beam	1
2.	Column	2
3.	Top Support	2
4.	Foot	2
5.	M8x1.25 12mm Self-Threading Screw	8
6.	M10x1.5 30mm Screw	4
7.	Handswitch	1
8.	Control Box	1
9.	Power Cord	1

**INDEPENDENT**

For tables 60" or Less

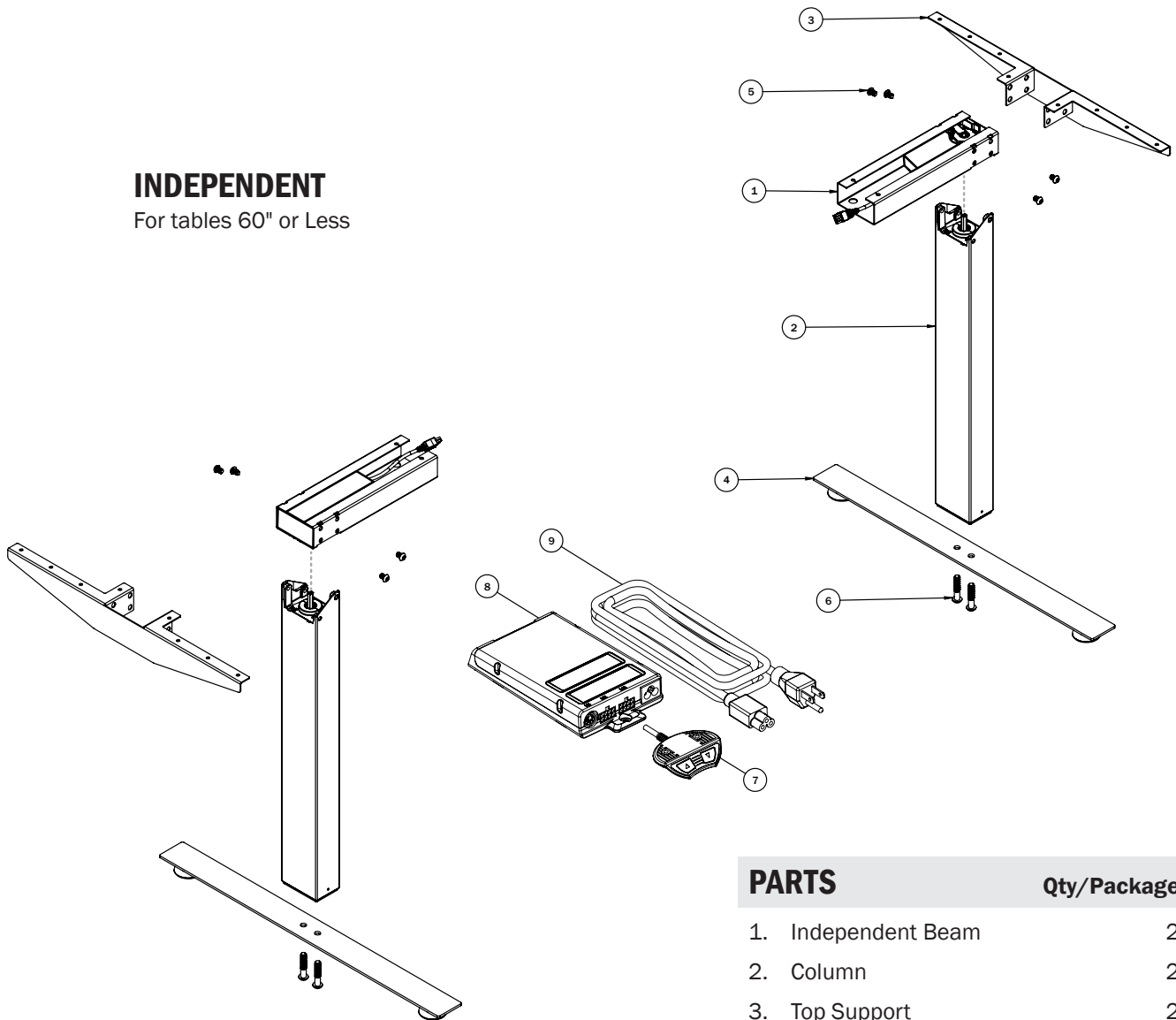

**DO NOT** remove the foam surrounding the motor.

**PARTS**

**Qty/Package**

1.	Independent Beam	2
2.	Column	2
3.	Top Support	2
4.	Foot	2
5.	M8x1.25 12mm Self-Threading Screw	8
6.	M10x1.5 30mm Screw	4
7.	Handswitch	1
8.	Control Box	1
9.	Power Cord	1

## INDEPENDENT WITH HAT CHANNEL

For tables 60"–84"

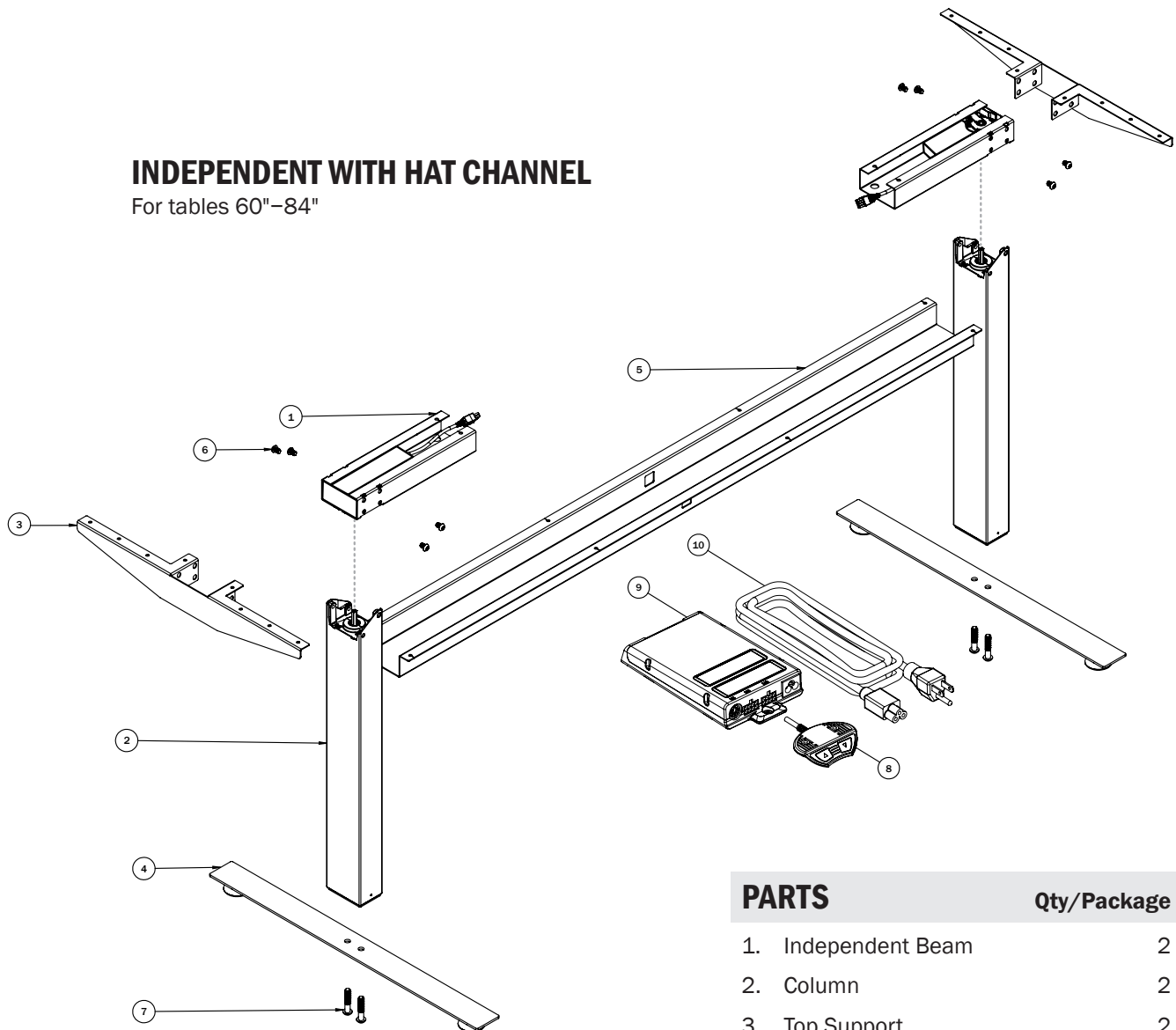

**DO NOT** remove the foam surrounding the motor.

### PARTS Qty/Package

PARTS	Qty/Package
1. Independent Beam	2
2. Column	2
3. Top Support	2
4. Foot	2
5. HAT Channel	1
6. M8x1.25 12mm Self-Threading Screw	8
7. M10x1.5 30mm Screw	4
8. Handswitch	1
9. Control Box	1
10. Power Cord	1

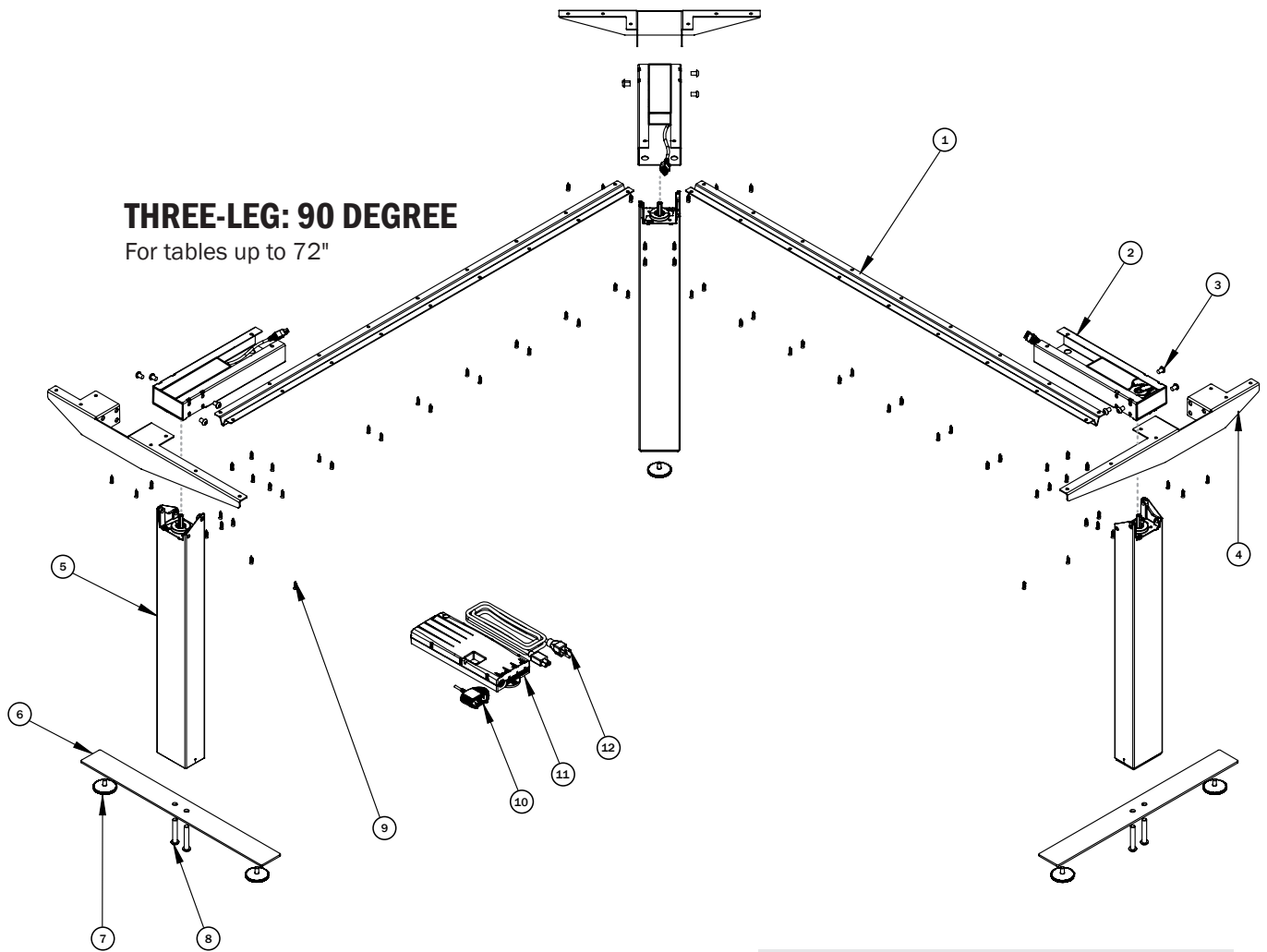

**THREE-LEG: 90 DEGREE**

For tables up to 72"

**PARTS Qty/Package**

1.	Support Beam	2
2.	Independent Beam	3
3.	M8x1.25 12mm Self-Threading Screw	12
4.	Top Support	3
5.	Column	3
6.	Foot	3
7.	Glide	5
8.	M10x1.5 50mm Screw	12
9.	#8-15 3/4" Screw	69
10.	Handswitch	1
11.	Control Box	1
12.	Power Cord	1

**DO NOT remove the foam surrounding the motor.**

**THREE-LEG: 120 DEGREE**

For tables up to 60"

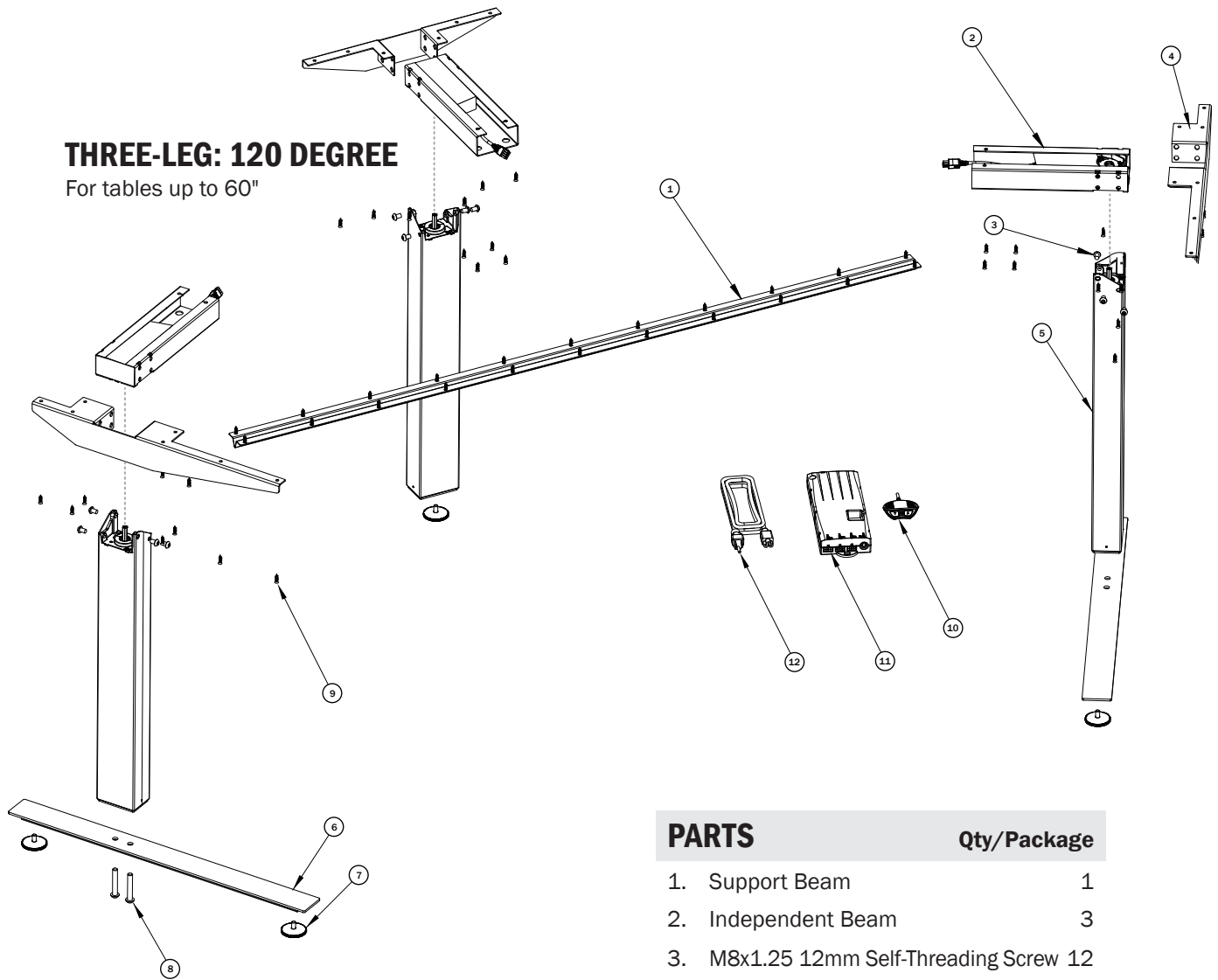

**DO NOT** remove the foam  
surrounding the motor.

**PARTS****Qty/Package**

1.	Support Beam	1
2.	Independent Beam	3
3.	M8x1.25 12mm Self-Threading Screw	12
4.	Top Support	3
5.	Column	3
6.	Foot	3
7.	Glide	6
8.	M10x1.5 30mm Screw	12
9.	#8-15 3/4" Screw	56
10.	Handswitch	1
11.	Control Box	1
12.	Power Cord	1



# SAFETY INFORMATION

## IMPORTANT SAFETY INSTRUCTIONS *Save these instructions.*

### **DANGER** To reduce the risk of electric shock:

Always unplug this furnishing from the electrical outlet before cleaning.

**WARNING:** To reduce the risk of death, serious injury, or property damage, read and follow this safety information and the provided instructions when assembling this product. Do not change or replace components and accessories provided by OMT-Veyhl.

## INSTALL ONLY APPROVED WORK SURFACES

This table system does not include a work surface (desktop). Work surface must be at least  $\frac{3}{4}$ " thick and weigh no more than 5 lb. per square foot (For example, a 2'x6' desktop should weigh no more than 60 lb). Do not exceed a maximum weight for the desktop of 75 lb. To prevent table from tipping or collapsing, make sure the desk frame is not overloaded by the weight of tabletop and objects you plan to put on the table. If you are unsure, contact customer service.

## KEEP AWAY FROM CHILDREN

This table system is not designed for use in homes or other areas accessible by small children. For indoor commercial office use only.

## BE CAREFUL WHEN ADJUSTING DESK HEIGHT

Body parts and property can be caught between the moving work surface and an immobile obstacle (such as shelves, furniture, window sills, or walls). Keep at least one inch of clearance around desk and make sure nothing is in table's path for its entire range of motion.

### **Before raising or lowering:**

- Check surroundings on all sides of desk are clear
- Make sure corded objects will not be pulled off table or cause other objects to fall
- Make sure desk power cord moves freely as desk moves up and down

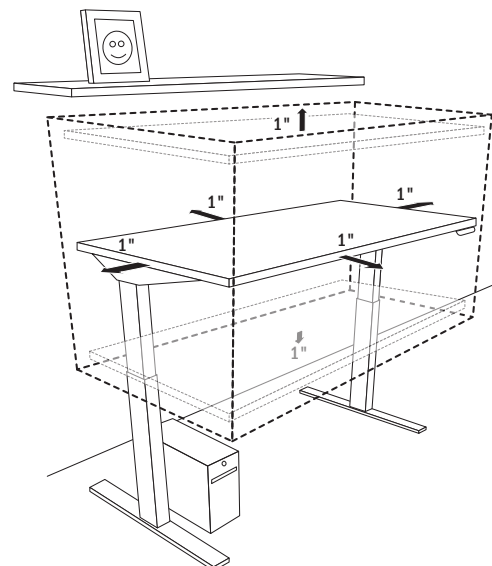

## DO NOT OVERLOAD DESK

To prevent table from tipping or collapsing, make sure the desk frame is not overloaded by the weight of tabletop and objects on table. Evenly distribute load; excess loads near edges can reduce stability and lead to tip over.

- Do not exceed maximum load (including weight of desktop) of 200 lb. (91Kg) for two-leg configuration, and 250 lb. (113 Kg) for three-leg configuration
- Do not exceed edge load of 25 lb. when positioning monitors or mounting accessories.
- Do not sit or stand on table

## USE CARE WHEN MOVING DESK

- Clear objects and equipment from table before rolling to reduce the risk of tipping over.
- Adjust the desk to its lowest height before moving
- To disconnect, turn all controls to the off position, then remove plug from outlet
- Do not move a loaded desk
- Do not lift the desk by the work surface (desktop)

## DO NOT OPEN ELECTRICAL COMPONENTS

Do not attempt to service table components. There are no user-serviceable parts inside the motor control units or table legs. If your table needs service, contact customer service. Never operate this furnishing if it has a damaged cord or plug, if it is not working properly, if it has been dropped or damaged. Return the furnishing to a service center for examination and repair.

## KEEP TABLE FRAME DRY

Keep all electrical components away from water and high humidity. Clean only with a dry or slightly damp cloth. Do not spray cleaning solutions directly onto table system.

## GROUNDING INSTRUCTIONS

This product is equipped with a cord having an equipment-grounding conductor and a grounding plug. **Use only the cord provided.** Make sure that the product is connected to an outlet having the same configuration as the plug (as shown in Illustration A) that is properly installed and grounded in accordance with all local codes and ordinances.

Do not modify the plug provided with the product – if it will not fit the outlet, have a proper outlet installed by a qualified electrician.

**No adapters are to be used with this product.**  
**Keep cord away from heated surfaces.**

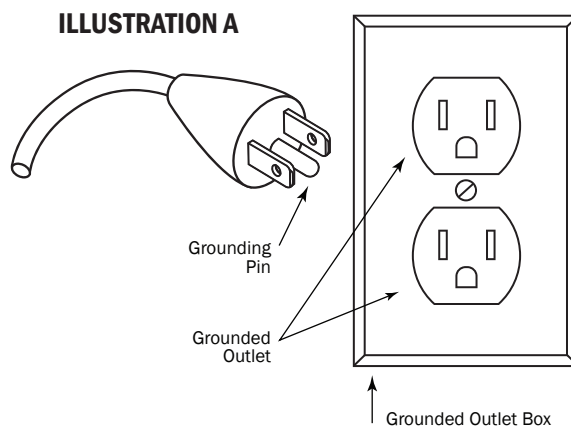

# ASSEMBLY INSTRUCTIONS

The assembly of the table frame to be made in accordance with this manual.  
Changes to the table frame or improper use may affect the safety, function, and life of your product.

*This manual is for all sit-stand tables from the OV1000 series.  
Due to different models or types, pictures may vary.*

## ASSEMBLY OVERVIEW

1. Assemble the foot to the column
2. Assemble the top support to the beam and column
3. Feed motor cables through beam or HAT channel cutout
4. Fasten the table frame onto the table top
5. Fasten the control box and handswitch to the table top
6. Connect the motor cables to the control box
7. Connect the handswitch (HS) cable to the control box
8. Connect the supplied power cord (AC) to the control box
9. Attach all cables to the table frame or on the underside of the table top

**DO NOT remove the foam surrounding the motor.**

If you have any difficulty assembling this unit, or need to order replacement parts, please contact our Customer Service department.  
Use the parts diagrams on page 4-8 as a reference.

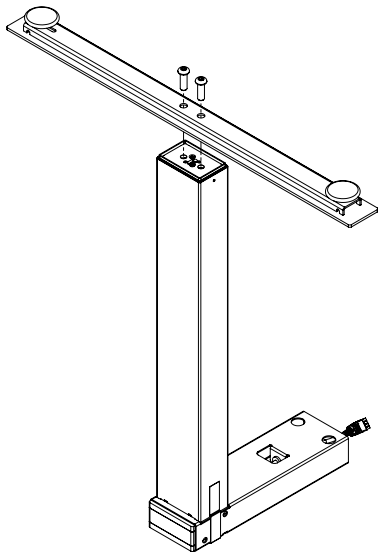

## 1 ASSEMBLE THE FOOT TO THE COLUMN

Assemble using the M10x1.5 x 30mm length screws (2 per column). The maximum tightening torque for these screws is 48Nm. (35 lbs-ft).

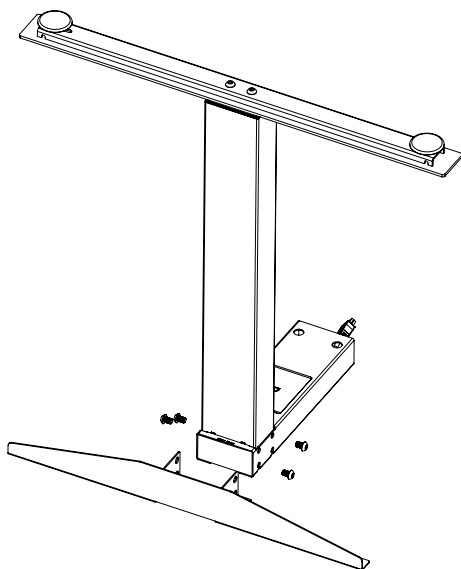

## 2 ASSEMBLE THE TOP SUPPORT TO THE BEAM AND COLUMN

Remove the tape surrounding the independent beam and column. Ensure the mounting holes in the column remain aligned with the corresponding holes in the independent beam.

Align top support holes with independent beam assembly. Assemble using the M8x1.25 x 12mm length screws (4 per column). An average fastening torque of 8Nm (6 lbs-ft) will be required to initially engage the screw in the hole. The maximum tightening torque for these screws is 20Nm (15 lbs-ft). Repeat as necessary for remaining columns.

### 3 FEED THE MOTOR CABLES THROUGH THE BEAM / HAT CHANNEL CUT OUT\*

\*For tables with a full length beam or HAT channel

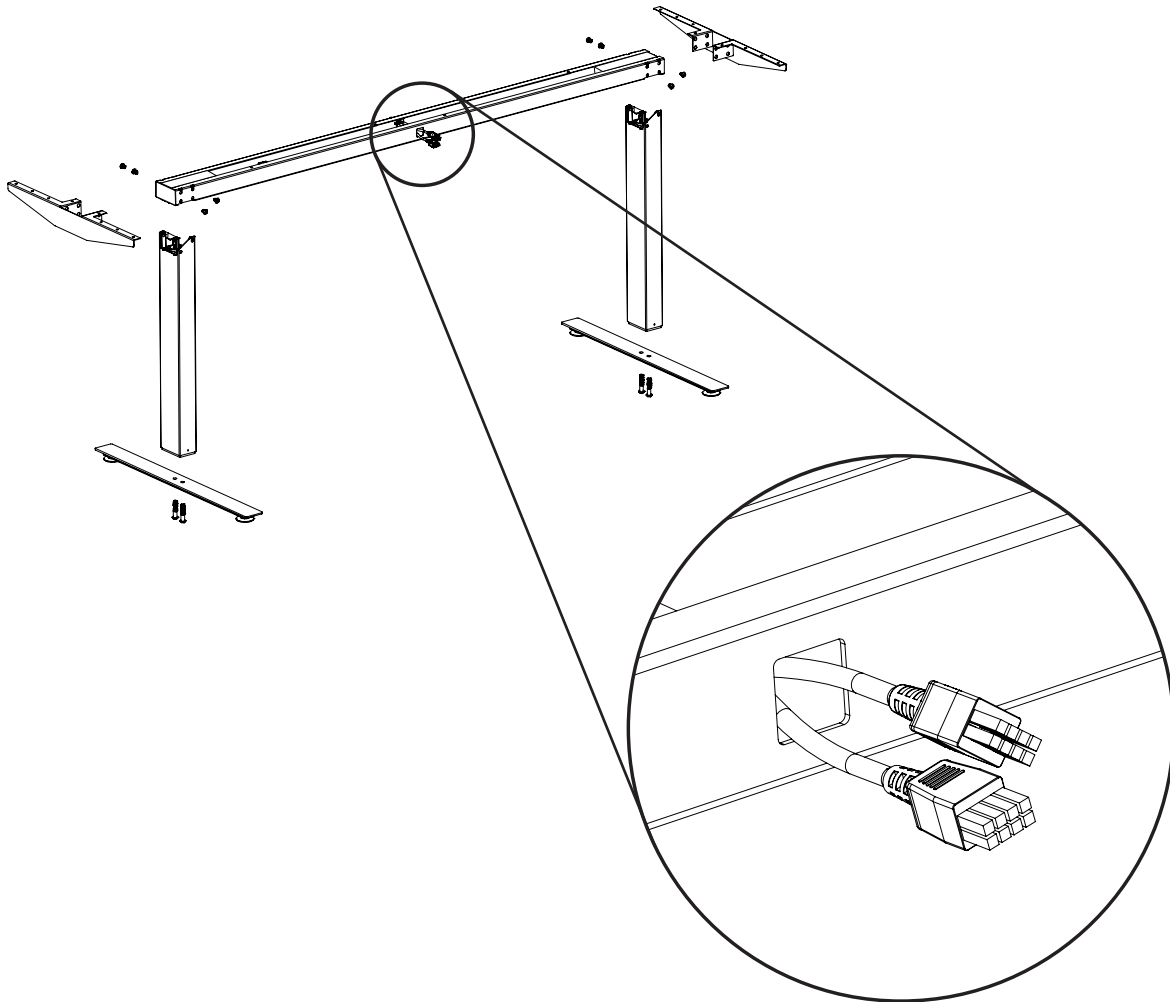

**4 FASTEN THE TABLE FRAME ONTO THE TABLE TOP**  
 Be sure to use approved screws per the table top supplier.

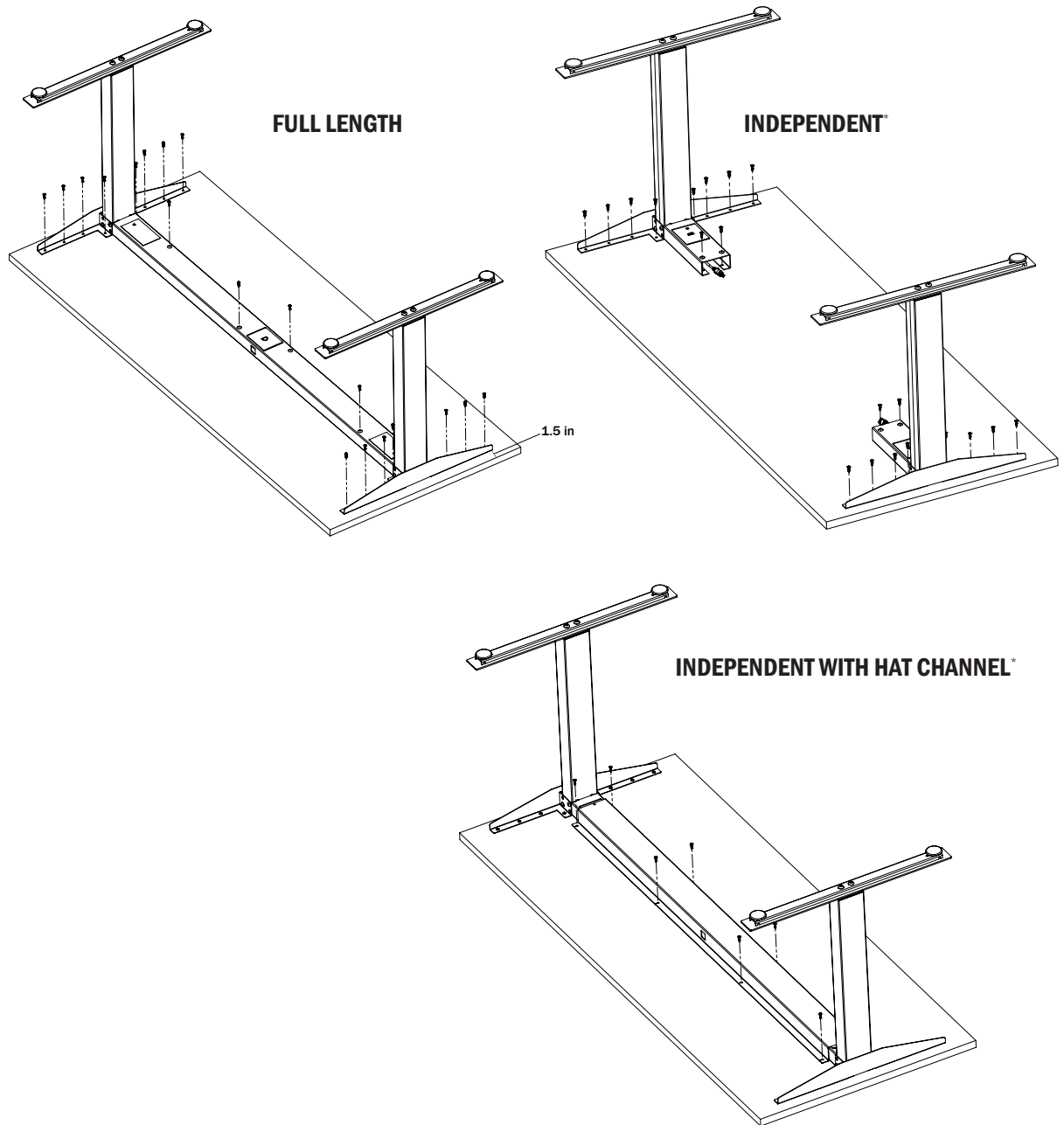

\*Please make sure top supports are mounted 1.5" from edge of work surface.

**THREE-LEG: 90 DEGREE**

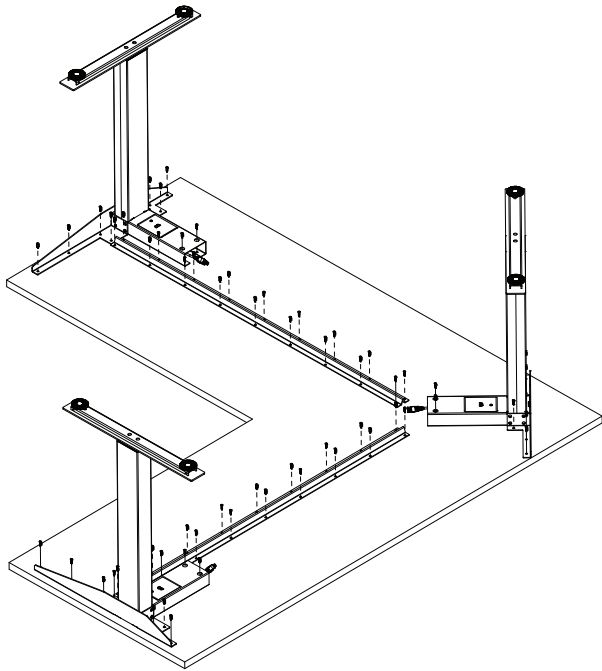

**TOP SIZE**      **A**

24in      8in  
30in      14in

**TABLE LENGTH**      **B**

72in

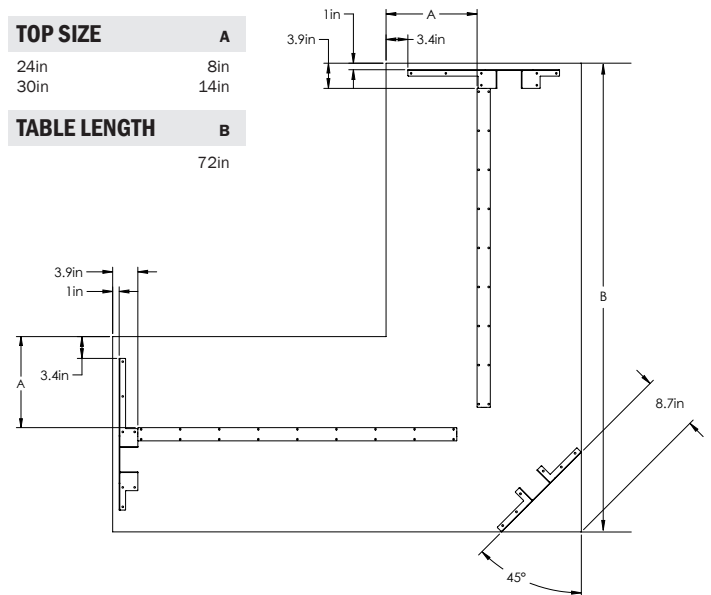

**THREE-LEG: 120 DEGREE**

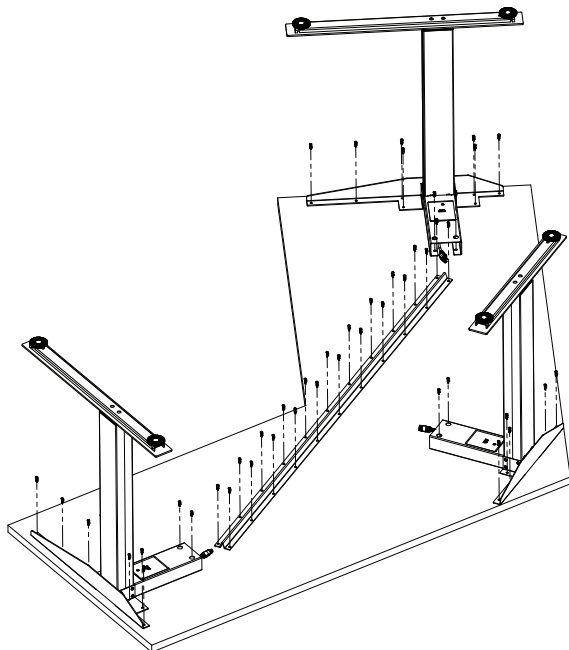
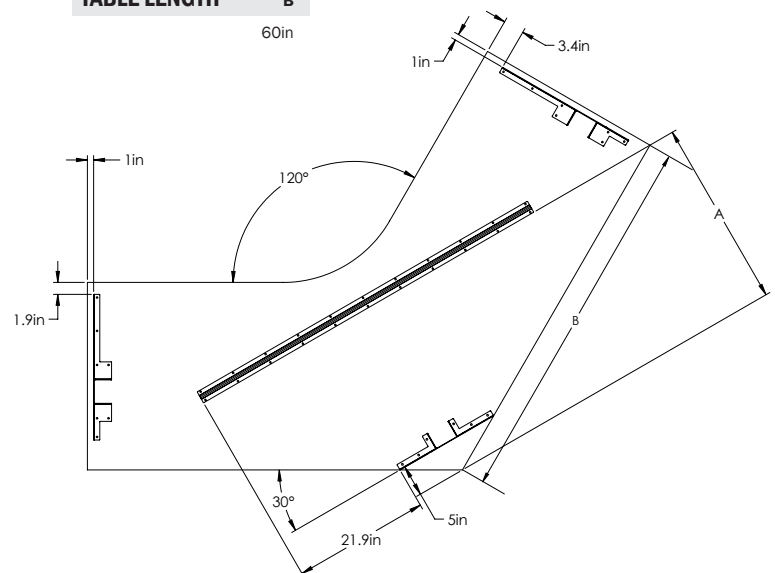

**TABLE DEPTH**      **A**

24in      24in  
30in      30in

**TABLE LENGTH**      **B**

60in



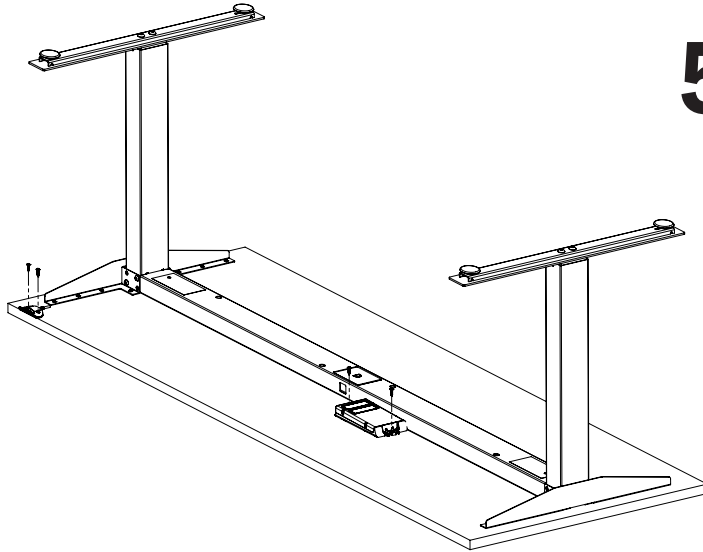

## 5 FASTEN THE CONTROL BOX AND HANDSWITCH TO THE TABLE TOP

Make sure the control box and handswitch are fastened in a location where all the cables will connect without being in tension. Be sure to use approved screws per the table top supplier.

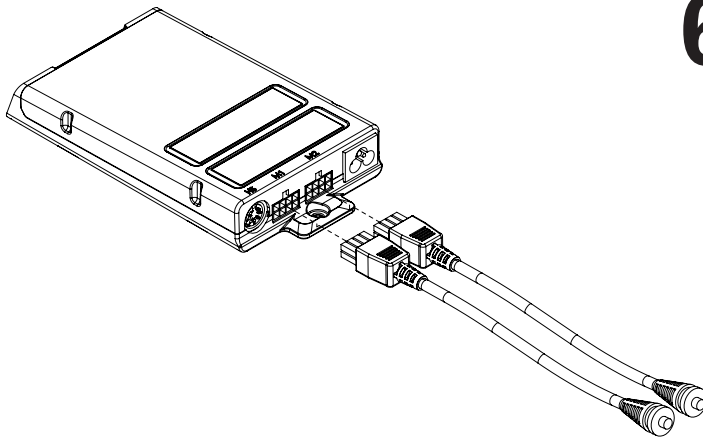

## 6 CONNECT THE MOTOR CABLES TO THE CONTROL BOX

The motor cable plug-connection has to click into place. If a control box is used which has more plug-terminals than needed, **you have to connect to M1 first.** (The extra terminals can be left open.)

Connections to the control box:  
 M1-M2 = Connectors for the columns  
 HS = Connectors for the handset  
 AC = Connector for the power cord (3-pin)



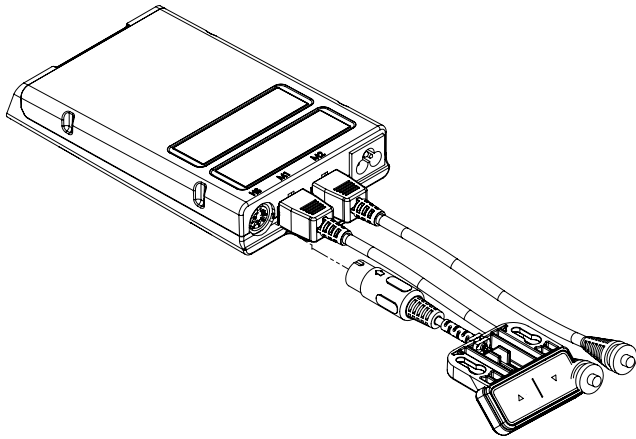

## 7 CONNECT THE HANDSWITCH (HS) CABLE TO THE CONTROL BOX

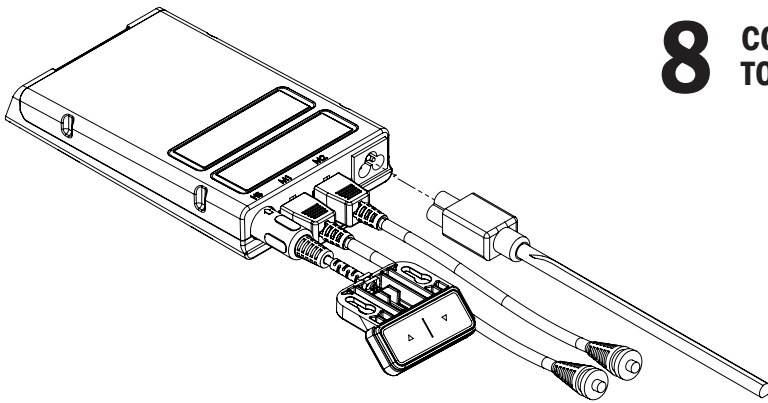

## 8 CONNECT THE SUPPLIED POWER CORD (AC) TO THE CONTROL BOX

## 9 ATTACH ALL CABLES TO THE TABLE FRAME OR ON THE UNDERSIDE OF THE TABLE TOP

Attach cables in order to avoid any damage during operation.

# OPERATION INFORMATION

## INITIALIZATION/RESET

The desk may need to be initialized/reset after any of the following:

- After assembly
- After disconnection from the power supply
- After any impact on the table top.

To initialize/reset, you will need to move the table to the lowest position by holding the DOWN button of the handswitch until all columns reach the lowest position. Then press the DOWN button again and hold it pressed for five seconds or until a slight movement of the table drops down to the machine zero point and back up to the operation zero point. Once the table stops moving, release the DOWN button. If the button is released too early, this leads to a malfunction of the table and you must repeat the reset process.

The upper height position is programmed into the control box. For this reason, only use the control box that has been provided with the specific table frame. **Under no circumstance should a control box from one table be moved to another.**

## NORMAL HANDSWITCH OPERATION (for all handswitch types)

By pressing the UP or DOWN buttons, the table will move up or down to the desired position. Once the desired position is reached, let go of the UP or DOWN button. The table will stop once it reaches the lower or upper height position.

## PROGRAMMABLE HANDSWITCH OPERATION (optional)

This programmable handswitch is equipped with a display for showing the current table height in centimeters or inches.

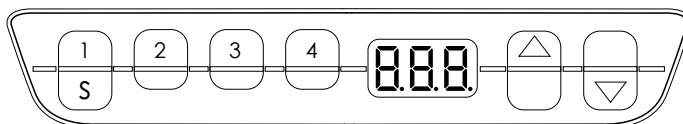

The handswitch also will display an error code if an error is detected by the control box. When an error is detected, the display will show an error code “EXX,” instead of the current table height. To resolve the error, see the Troubleshooting Section (p. 16-17 of this guide).

The programmable handswitch also has the ability to save up to four different height positions.

## **PROGRAMMABLE HANDSWITCH OPERATION** (continued)

### **CHANGE THE HEIGHT UNIT** (inches or centimeters)

The height display of the handset can display either centimeters or inches. With the help of the S5-menus, the unit can be changed. If the display was originally set to centimeters, then after the procedure noted below it will change to inches or vice versa.

To change the unit, follow these steps:

1. Press and hold the 1, 2, and UP buttons for 5 seconds until the display shows "S 5".
2. Confirm by pressing the "S" button. Now the display will have changed.

To exit the menu without making a selection, wait approximately 10 seconds until the height display appears again.

### **ADJUSTMENT OF THE HEIGHT DISPLAY**

If the indicated value does not match the actual height of the table top, the display can be corrected as follows:

1. Press and release the "S" button.
2. Press and hold the DOWN button for 5 seconds until the display starts to flash.
3. Measure the table height and enter the measured value (depending on the setting in centimeters or inches) with the UP or DOWN button. Confirm the entry by pressing the "S" button.

To exit the menu without making a selection, wait 10 seconds and the height display will appear again.

### **SAVE MEMORY POSITION**

Drive the table up or down to the desired height. Press the "S" button (in the display "S -" is shown.) Select a position by pressing on any of the four number buttons, 1-4, (the display will show the setting as "S1"). The save position procedure is confirmed by the control box with a double click sound. After approximately 5 seconds, the display shows the current table height. Repeat steps to save a maximum of four different positions.

### **RECALL MEMORY POSITION**

Press and hold the desired memory location button (1, 2, 3 or 4) and the table moves independently from the current position into the saved position. The button must be pressed until the position is reached. If the button is released, the table will stop short of the desired height.

# TROUBLESHOOTING

## UNIT

ERROR CODE	SOURCE	SOLUTION
<b>Table does not move</b>	No power supply	Plug in the power cord or check the connection on the control box
	No connection or a loose connection to the drives	Verify the plug connections of the motor cable to the control box
	No connection or a loose connection to the handswitch	Verify the plug connections of the motor cable to the control box
	Max lifting capacity is exceeded	Reduce the weight or load on the desktop
	Max time limit is exceeded	Control is activated automatically after approx. 9 minutes
	Defective drive	<b>Contact customer service</b>
	Defective control box	<b>Contact customer service</b>
	Handset is defective	Replace the handset
<b>Table moves down at a slow rate</b>	Control box expects new reset	Reset control box. (See page 18)
<b>During operation, tables moves at a slow rate</b>	Max lifting capacity is exceeded	Reduce weight
<b>Table moves on one side only briefly and then stops</b>	No connection or a loose connection to the drives	Verify the plug connections of the motor cable to the control box and reset the control box
	Defective drive	<b>Contact customer service</b>

## HANDSWITCH DISPLAY

ERROR CODE	SOURCE	SOLUTION
<b>HOT</b>	The control box monitors the duty cycle (time-controlled) and its max temperature. A value has been exceeded.	Wait until the “HOT” display goes out - the table is working properly again
<b>E00</b>	M1 – Internal Fault	Unplug and <b>contact customer service</b>
<b>E01</b>	M2 – Internal Fault	
<b>E02</b>	M3 – Internal Fault	
<b>E12</b>	M1 – Defect	Unplug. Correct the external short circuit and/or verify the cable to the drives. Plug cables into the control box and re-run table.
<b>E13</b>	M2 – Defect	
<b>E14</b>	M3 – Defect	
<b>E24</b>	M1 – Overcurrent	Collision → resolve if necessary
<b>E25</b>	M2 – Overcurrent	Max load exceeded → remove excess load from the table
<b>E26</b>	M3 – Overcurrent	If the problem still exists, please <b>contact customer service</b>
<b>E36</b>	M1 – Not connected	Motor not connected. Check cable / connector to the drive. Reset the table (see page 18).
<b>E37</b>	M2 – Not connected	
<b>E38</b>	M3 – Not connected	
<b>E48</b>	Overcurrent drive 1	Collision → resolve if necessary
<b>E49</b>	Overcurrent drive 2	Max load exceeded → remove excess load from the table
<b>E55</b>	Drive 1 - Synchronization is lost	If necessary, reduce the load on the table
<b>E56</b>	Drive 2 - Synchronization is lost	Reset the table (see page 18)
<b>E60</b>	Collision identified	Option ISP function. Remove source.
<b>E61</b>	Drive replaced	The connection to the drive is interrupted or a new drive is connected. Reset the table (see page 18).

If it is not possible to resolve an error as described, disconnect the power cord, wait a few minutes and reset the table again.  
If the error still occurs, remove the table from the power source and contact customer service.

(Error Code list is valid from firmware 1.7.5 and higher)

# TECHNICAL DATA

GENERAL CONTROL BOX	
<b>Power supply</b>	120 VAC ±10% / 60 Hz
<b>Standby power consumption, primarily</b>	<0.3 W
<b>Operating temperature</b>	0-35 °C
<b>Protection class</b>	IP 20
<b>Maximum power output</b>	216VA/24V

  

TWO-COLUMN FRAME WITH CONTROL BOX	
<b>Maximum lift capacity</b>	200 lb (≈ 90 kg / 890N)
<b>Adj. range, depending on version</b>	View Illustration B
<b>Maximum input current</b>	5 A
<b>Maximum duty cycle</b>	10% (2 min. on / 18 min. off)

THREE-COLUMN FRAME WITH CONTROL BOX	
<b>Maximum lift capacity</b>	250 lb (≈ 113 kg / 1112N)
<b>Adj. range, depending on version</b>	View Illustration B
<b>Maximum input current</b>	6.5 A
<b>Maximum duty cycle</b>	10% (2 min. on / 18 min. off)

ILLUSTRATION B

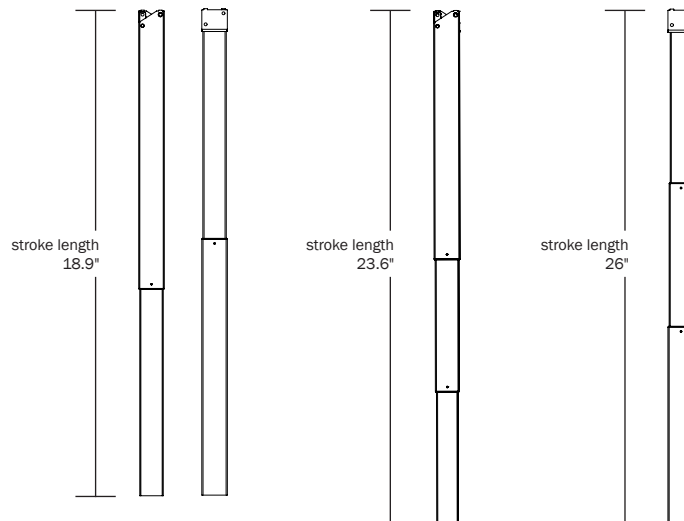

# STANDARDS & CERTIFICATIONS

The drive system is tested according to the following standards:

UL 962

Issued: 2014/11/07 Ed: 4 Household and Commercial Furnishings

CSA C22.2#68

Issued: 2009/09/01 Ed: 7 (R2014)

Motor-Operated Appliances (Household and Commercial);

Gen. Inst. No.1: 2010, Gen. Inst. No.2: 2010

Meets 2014 BIFMA standards.

# WARRANTY

**CONTACT YOUR SALES REPRESENTATIVE FOR WARRANTY INFORMATION**

**INTERTEK LISTING BELONGS TO:** System: Clever  
OMT-Veyhl USA  
11511 James Street  
Holland, MI 49424



End of life cycle: Once product is disassembled, all steel components can be recycled at your local metal collector.  
For products with electronic components, see Disassembly Guide.

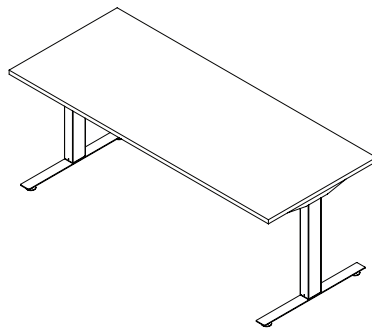

# **OV1000**

## **USER GUIDE**

Part No. 23624