











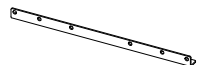

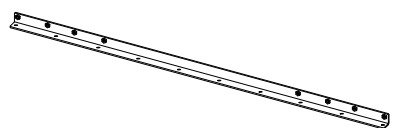



Assembly & Installation Instructions: Sierra 3-Leg Desk in a Box SEHX7890-4272OC-XXX-XX-X

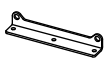

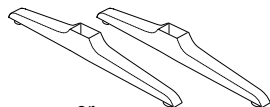
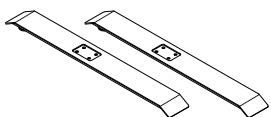

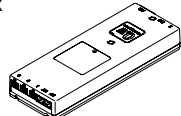
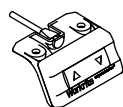
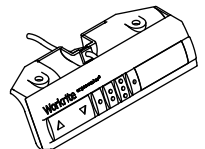
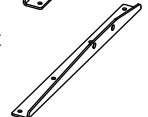

Parts Included, Frame Set

Box 1

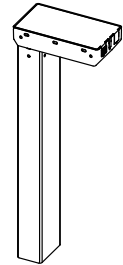
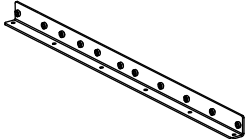
<p>A Leg Qty: 2</p> 	<p>I #M6 × 14 mm Flat Head Cap Screw Qty: 30</p> 	<p>Q 3/16" Cable Loops Qty: 15</p> 
<p>B Rear Bracket Qty: 2</p> 	<p>J 4 mm Allen Wrench Qty: 1</p> 	<p>R #8 × 5/8" Pan Head Screw Qty: 18</p> 
<p>C Connector Bracket Qty: 1</p> 	<p>K #12 × 3/4" Pan Head Laminate Top Screw Qty: 61</p> 	<p>S Leg Cable, 1 Meter Qty: 2</p> 
<p>D #M6 × 12 mm Flat Head Cap Screw Qty: 6</p> 	<p>M Foot Glides Qty: 5</p> 	<p>S Style or Flat Foot Kit Qty: 1</p> 
<p>E Short Bracket Qty: 2</p> 	<p>N #12 x 2" Flat Head Screw Qty: 2</p> 	<p>V Power cord Qty: 1</p>  <p style="text-align: center;">or</p> 
<p>F Left End Bracket Qty: 1</p> 	<p>O Control Box Qty: 1</p> 	<p>W Standard or Programmable Switch Qty: 1</p>  <p style="text-align: center;">or</p> 
<p>G Right End Bracket Qty: 1</p> 	<p>P Cable Spool Qty: 3</p> 	

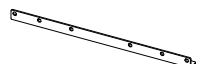
Sold separately: Worksurface

Box 2

<p>A Leg Qty: 1</p> 	<p>C Connector Bracket Qty: 1</p> 	<p>L Corner Foot Qty: 1</p> 
<p>B Rear Bracket Qty: 1</p> 	<p>E Short Bracket Qty: 1</p> 	<p>T Leg Cable, 2 Meters Qty: 1</p> 
<p>H Corner End Bracket Qty: 1</p> 		

⚠️ WARNING: Maximum loading of table assembly is 225 lb. (102 kg.). Maximum load includes the weight of the table top itself, any equipment placed upon it, and any equipment suspended or hanging under it. Loading should be evenly distributed over table surfaces. “Payload Capacity” is the Workrite Ergonomics recommended maximum loading which includes the Workrite sourced worksurface.

Sierra 2-Leg

V = 120 VAC, 60 Hz / 4.25 A maximum

IMPORTANT SAFETY INSTRUCTIONS:

When using an electrical furnishing, basic precautions should always be followed, including the following: Read all instructions before using this Sierra Workcenter.

DANGER: To reduce the risk of electric shock, always unplug this Sierra Workcenter from the electrical outlet before cleaning.

⚠️ WARNING: To reduce the risk of burns, fire, electric shock, or injury to persons:

1. Unplug from outlet before putting on or taking off parts.
2. Close supervision is necessary when this furnishing is used by, or near children, invalids, or disabled persons.
3. Use this furnishing only for its intended use as described in these instructions. Do not use attachments not recommended by the manufacturer.
4. Never operate this furnishing if it has a damaged cord or plug, if it is not working properly, if it has been dropped or damaged, or dropped into water. Return the furnishing to a service center for examination and repair.
5. Keep the cord away from heated surfaces.
6. Do not use outdoors.
7. Do not operate where aerosol (spray) products are being used or where oxygen is being administered.
8. To disconnect, remove plug from outlet.
9. Each surface intended to support an equipment payload capacity of 225 pounds.

FOR COMMERCIAL USE ONLY

SAVE THESE INSTRUCTIONS



IMPORTANT NOTE!

You must complete initialization (Step 14) at the end of assembly or your workcenter WILL NOT FUNCTION PROPERLY.

✓ Verify that you have all the tools needed for the assembly

You will need the following tools:

- #2 tip Phillips screwdriver or drill/driver
- #3 tip Phillips screwdriver or drill/driver
- M4 tip bit or 4 mm Allen Wrench (E)

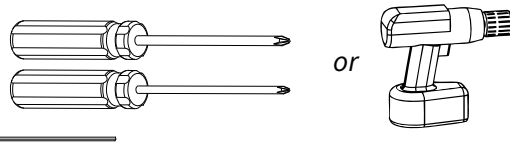

or

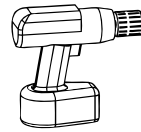

If you do not have a Workrite worksurface, you will also need:

1/8" pilot drill bit

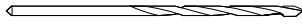

3/32" pilot drill bit



1 Assemble Rear Brackets Set

Assemble Rear Brackets (Q) to Connector Bracket (R) using #M6 × 12 mm Flat Head Cap Screws (S).

Use this guide to determine the correct holes for mounting based on the width of your workcenter.

Tighten securely.

Note: Workrite Brackets can be sized in 3" increments for any non-Workrite top.



To avoid stripping the threads, always insert and make the first few turns of the screw **BY HAND** with an Allen wrench (E), ensuring it is in straight.

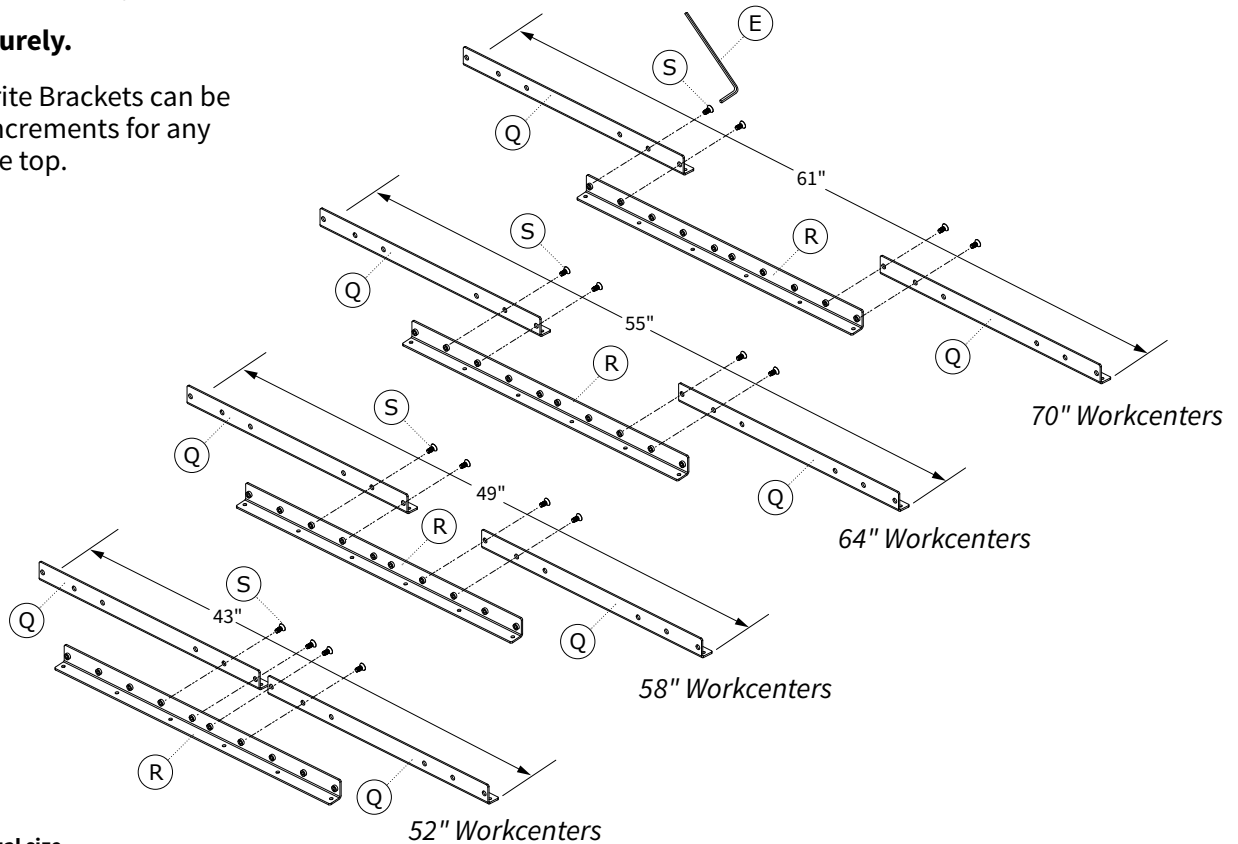

Hardware at actual size

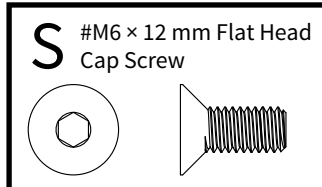

Note!

Only use the #M6 × 12 mm Flat Head Cap Screw (S) for assembly.

Note: Brackets can be sized in 6" increments for any non-Workrite top.

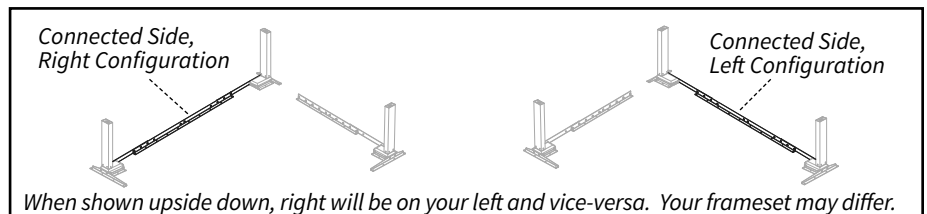

2 Attach Short & Medium Brackets

- 2.1 Attach Short Brackets (E) using #M6×14 mm Flat Head Cap Screws (I) to all three Legs.
- 2.2 Attach Right End Bracket (G) to sides of the Right Leg (A) using #M6 × 14 mm Flat Head Cap Screws (I). Attach Left End Bracket (F) to sides of the Left Leg (A) using #M6 × 14 mm Flat Head Cap Screws (I).
- 2.3 Attach Corner End Bracket (H) to the Center Leg (A) using #M6 × 14 mm Flat Head Cap Screws (I).
- 2.4 Attach both the Connected Rear Bracket (B & C assembled) and Floating Rear Bracket (B or B & C assembled) using #M6 × 14 mm Flat Head Cap Screws (I).



To avoid stripping the threads, always insert and make the first few turns of the screw **BY HAND** with an Allen wrench (J), ensuring it is in straight.

Make sure the Connected Rear Bracket is on the longer of the two sides.

Tighten securely.

Hardware at actual size

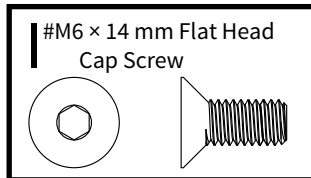

Caution!

Only use the #M6 × 14 mm Flat Head Cap Screw (I) for assembly.

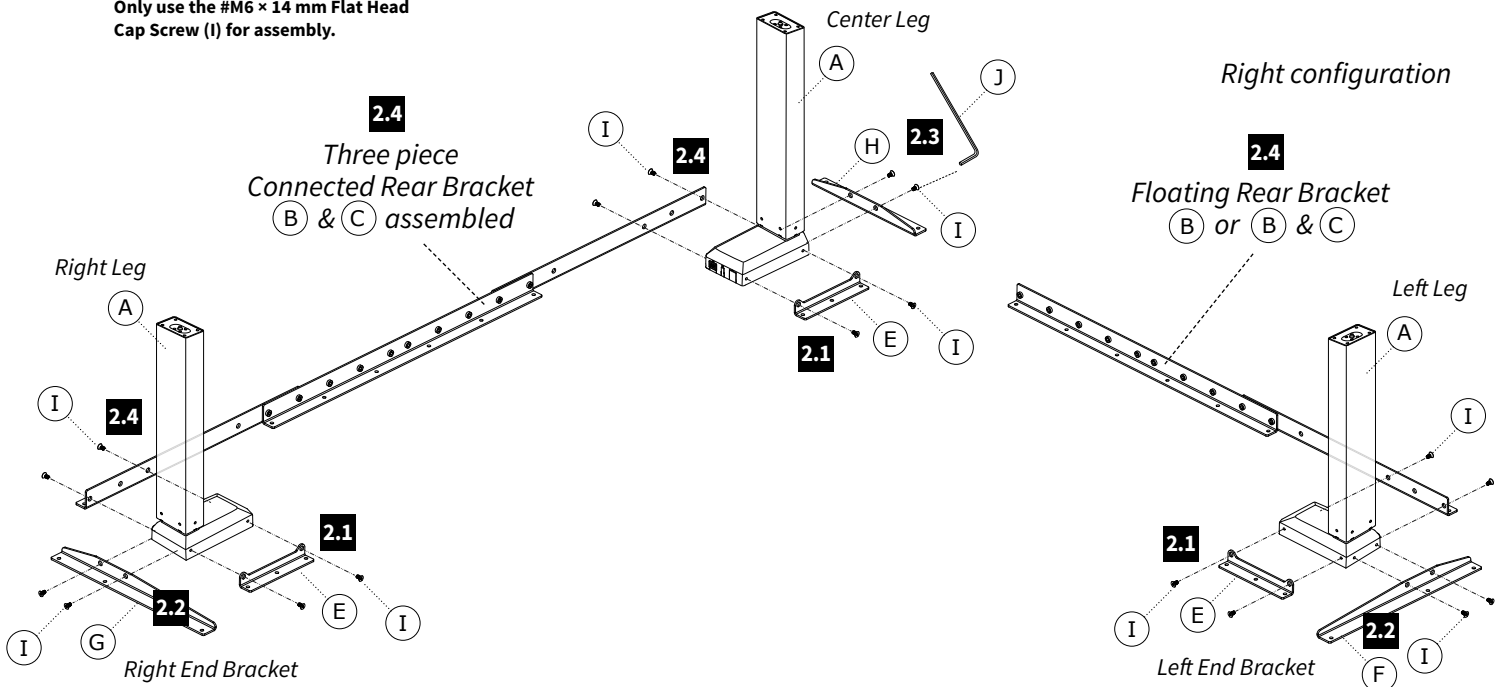
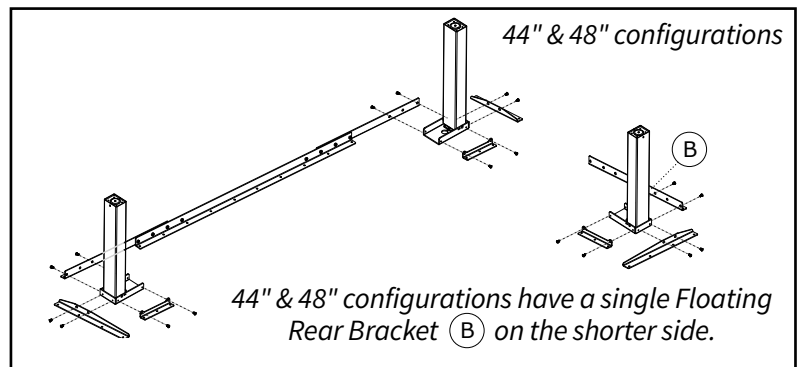

Note: The Right End Bracket (G) will be on your left when upside down.

Note: Left configurations will assemble as a mirror image of these instructions.

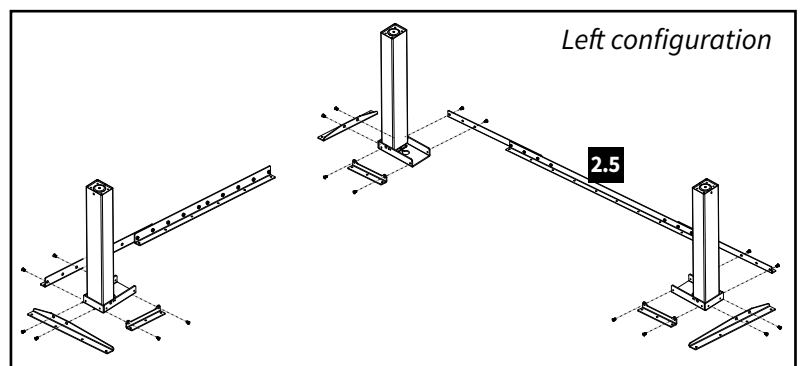

3 Attach Base to Pre-Drilled Workrite Worksurface

If you have a non-Workrite worksurface, skip to Step 5

- 3.1 Position leg assembly to align mounting holes in brackets to pre-drilled holes in worksurface.
- 3.2 Attach at the six corner locations using #12×¾" Pan Head Laminate Top Screws (K). If you use an electric screwdriver, be sure it is on the lowest torque setting to avoid stripping the holes in the top.

Hardware at actual size

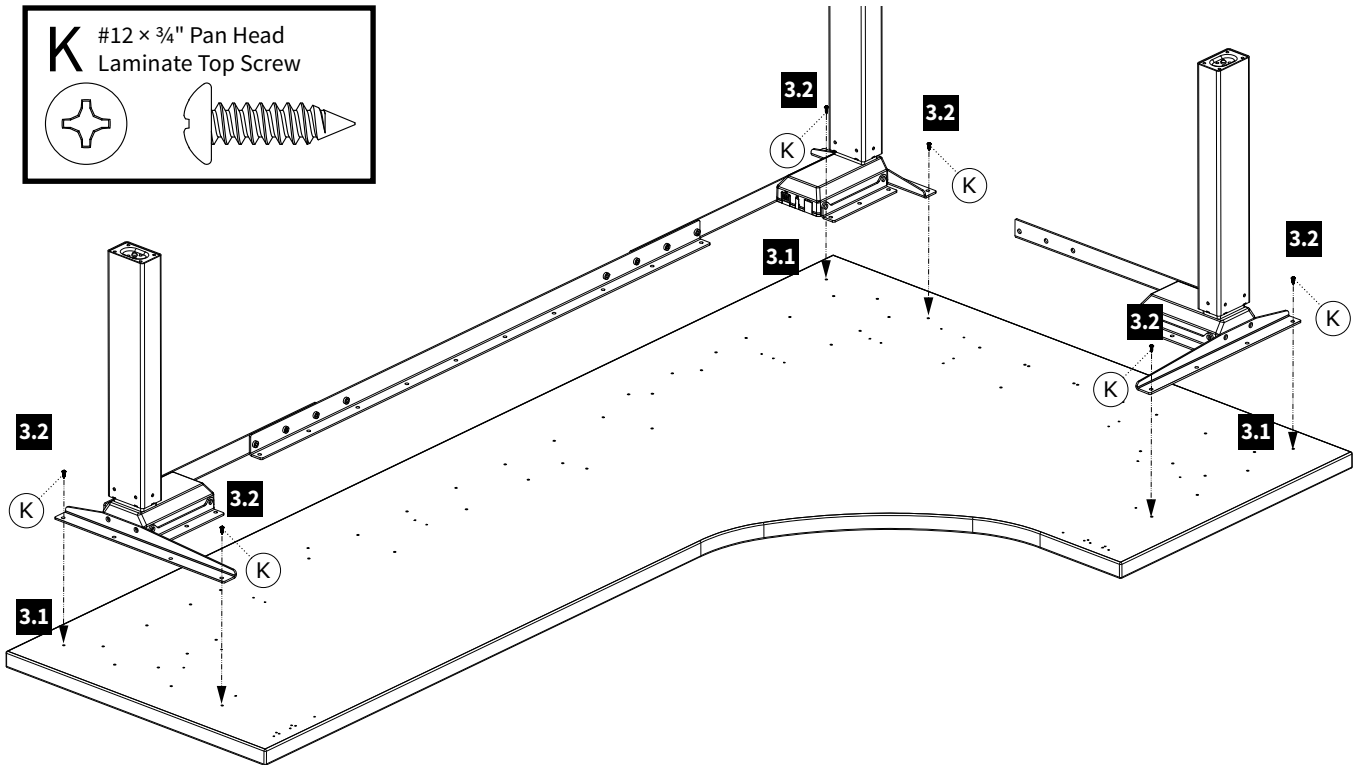
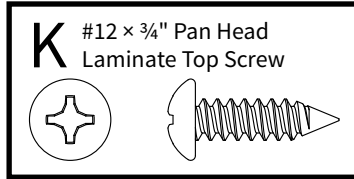

- 3.3 With frame set positioned and the six corner screws secure, attach the frame set using the remaining using #12×¾" Pan Head Laminate Top Screws (K).

Skip to Step 5.

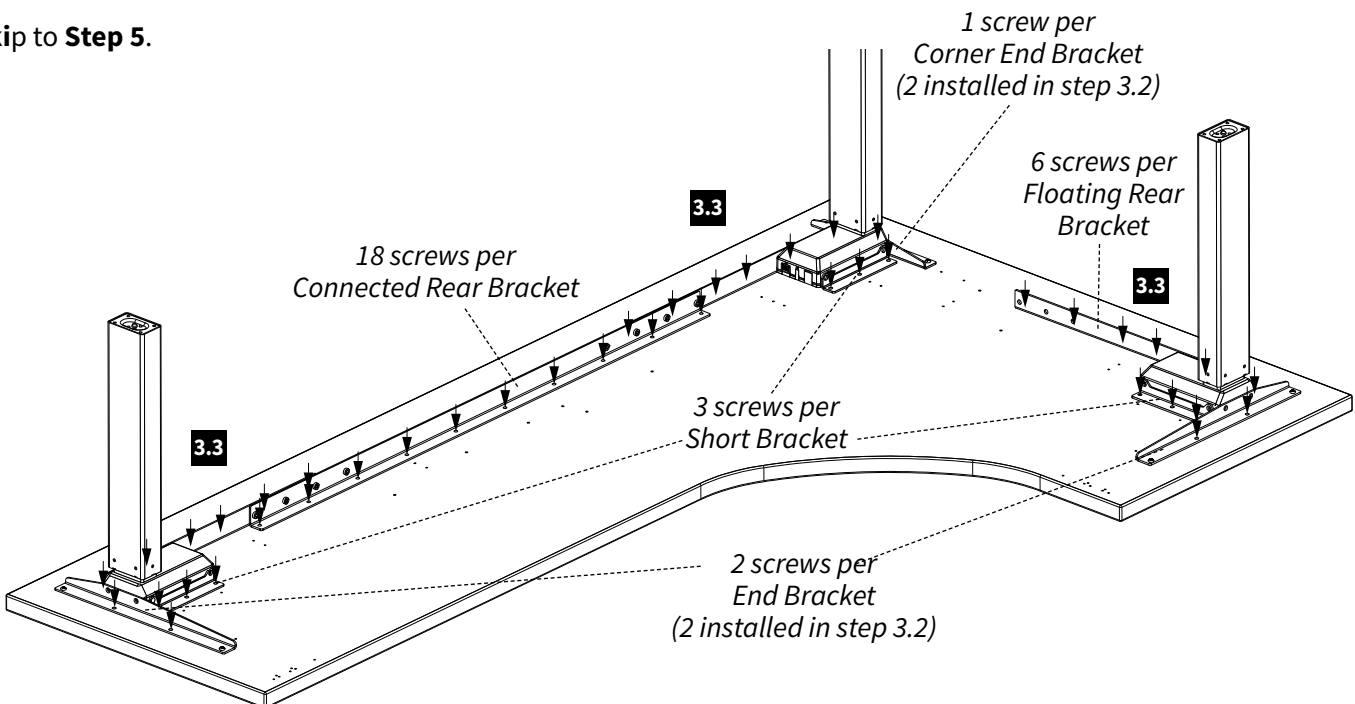

4 Attach Base to Non-Workrite Worksurface



Note: Avoid trip or tip hazards!
For uniquely shaped, non-standard worksurfaces, it is the installer's responsibility to position the worksurface to minimize extended overhangs and position feet fully under the worksurface.

- 4.1** Position Leg Assembly 2.875" from the sides and 6.125" from the front of the worksurface, making sure it runs parallel to the back edge of the worksurface.
- 4.2** Use 1/8" drill bit to drill pilot holes at the six corner locations. You may wish to mark your drill bit so you do not drill any more than 3/4" deep and damage your worksurface top.

Do not drill all the way through worksurface!

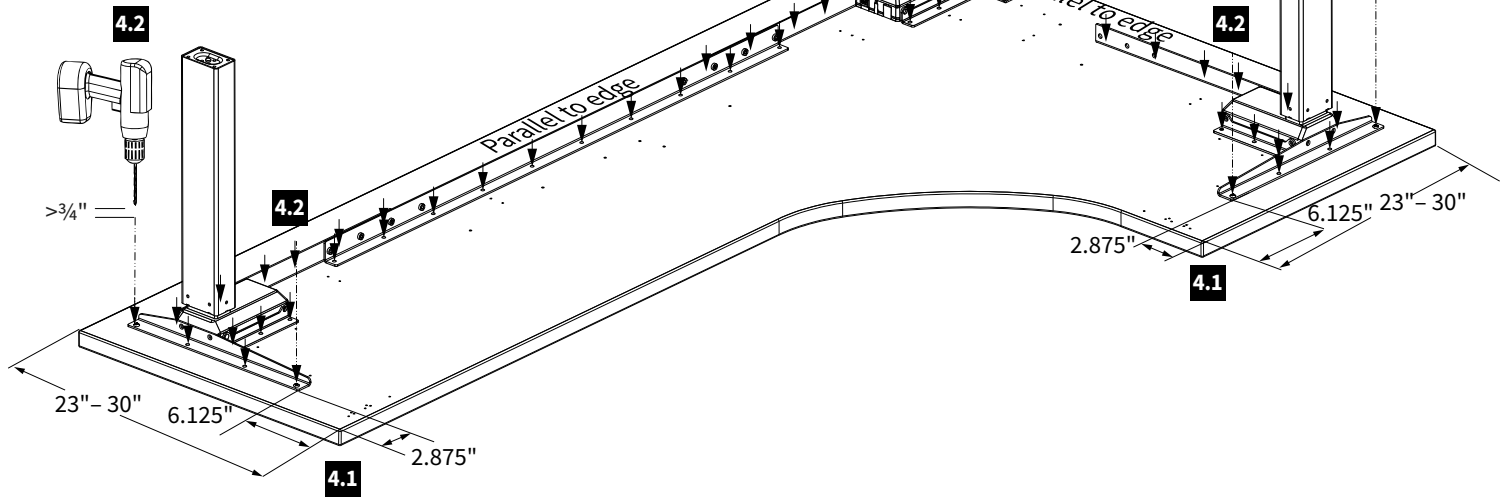

- 4.3** Attach at the six corner locations using #12x3/4" Pan Head Laminate Top Screws (K). If you use an electric screwdriver, be sure it is on the lowest torque setting to avoid stripping the holes in the top.
- 4.4** With frame set positioned and the six corner screws secure, drill pilot holes first then attach the frame set using the remaining #12x3/4" Pan Head Laminate Top Screws (K).

Do not drill all the way through worksurface!

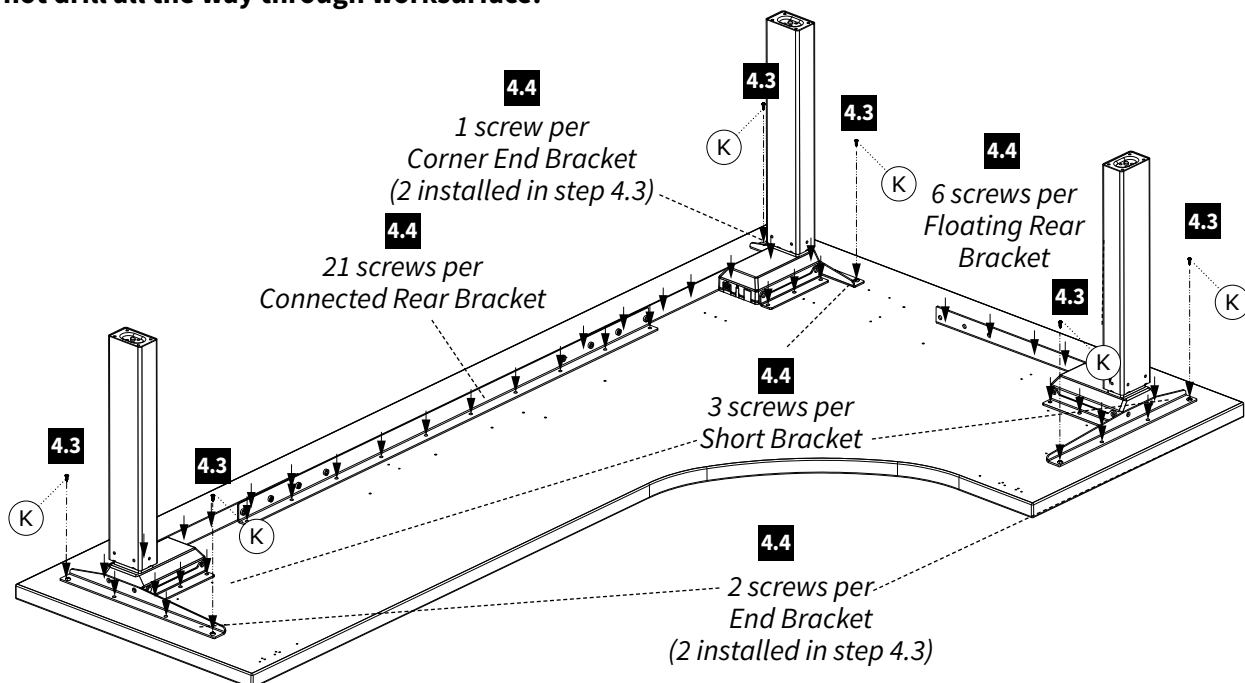

5 Attach Feet & Install Foot Glides

- 5.1 Attach one Foot Glide (M) into Corner Foot (L).
- 5.2 Attach Corner Foot (L) to bottom of center leg (A) with four #M6 × 14 mm Flat Head Cap Screws (I) and tighten securely.
- 5.3 Install outside feet (V) using eight #M6 × 14 mm Flat Head Screws (I) included with this Frame Set.
- 5.4 Attach the remaining Foot Glides (M) to bottom of the Feet supplied in your Foot Kit.

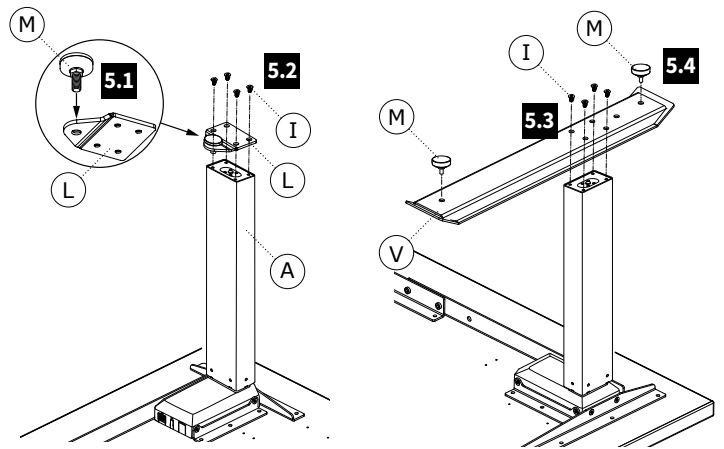

Flat Foot shown

Hardware at actual size

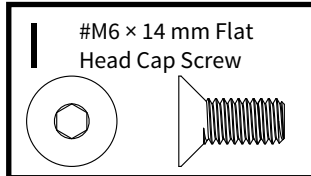

Note!

Only use the #M6 × 14 mm Flat Head Cap Screw (I) supplied with Corner Foot and Foot Kit for assembly.

6 Attach Switch (Packaged Separately)

Install your switch (W) using two #8 × 5/8" Pan Head Screws (R).

Note that there are two Switch locations. Consider Cable length when installing on large 3-Leg Workcenters. You may need to mount the Switch on the side closest to the Control Box (O).

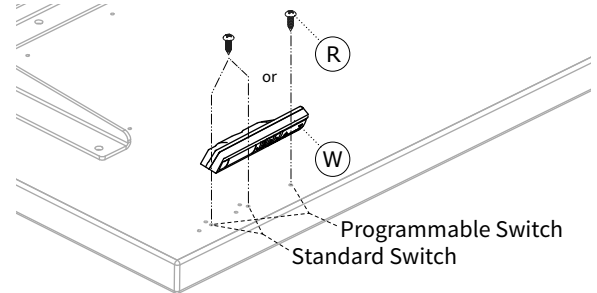

Programmable Switch shown

7 Loop Power Cord & Center Leg Cable through Strain Relief on Control Box

- 7.1 Loop the Power Cord (U) through the strain relief channel on the bottom of the Control Box (O) as shown. Leave 8" of slack to route cord
- 7.2 Thread the 1 meter Leg Cable (S) from the Center Leg through the cable channel on the bottom of the Control Box as shown. Leave 8" of slack to route cable.
- 7.3 Plug Power Cord (U) into power outlet AC on the Control Box (O).
- 7.4 Plug Leg Cable (S) into port "3" on the Control Box.
- 7.5 Lay the Control Box down in installation location with cables in place.

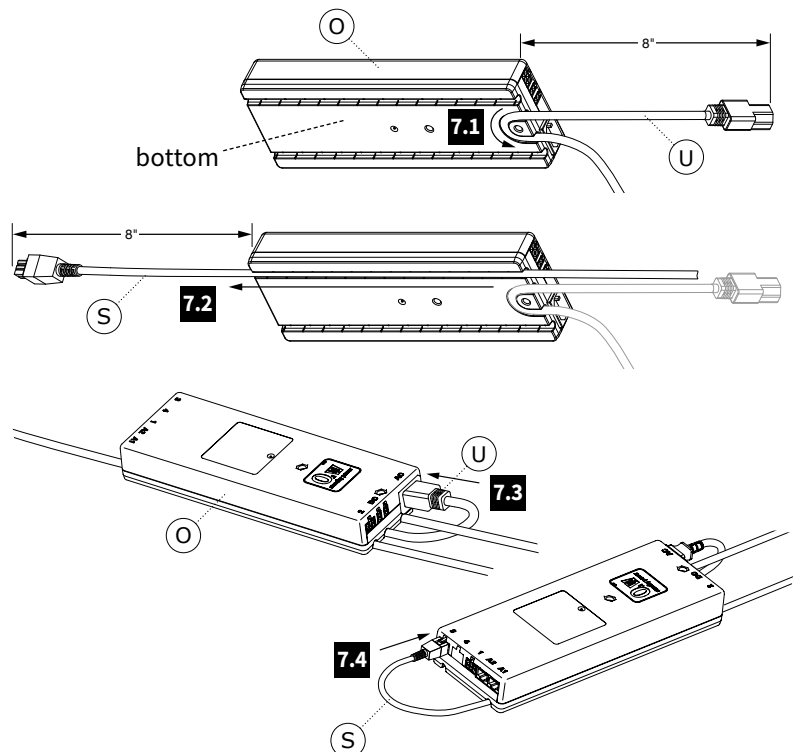

8 Attach Control Box & Cable Spools to Worksurface

8.1 Position Control Box (O).

If you have a Workrite worksurface:

Locate the two pilot holes for the Control Box and proceed to **Step 8.2**.

If you do not have a Workrite worksurface:

Place Control Box (O) in position and use a pencil to mark pilot hole placement. Control Box should be placed towards rear center of worksurface as shown. Remove Control Box and drill pilot holes where marked. **Do not drill all the way through tabletop!**

8.2 With Control Box (O) positioned over pilot holes, attach with two #12 × 2" Flat Head Screws (N).

8.3 Attach Cable Spool (P) with the #12 × 3/4" Pan Head Screw (K) to underside of worksurface. If you do not have a Workrite worksurface, mount Cable Spools (P) in a convenient location between legs and control box.

8.4 Lay out Leg Cables (S & T) to be sure they all reach the Control Box.

Hardware at actual size

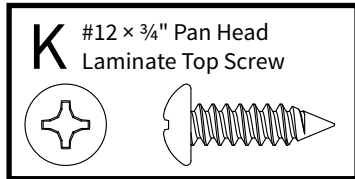

Hardware at actual size

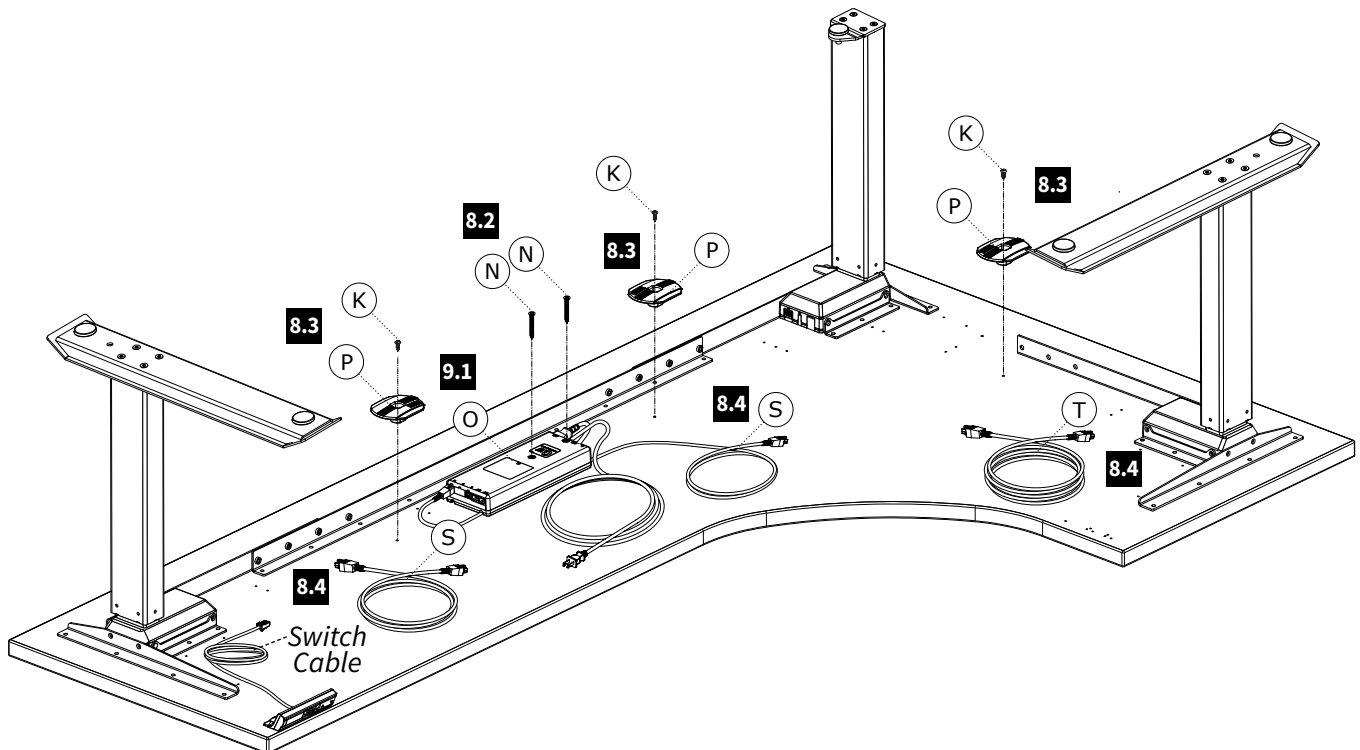
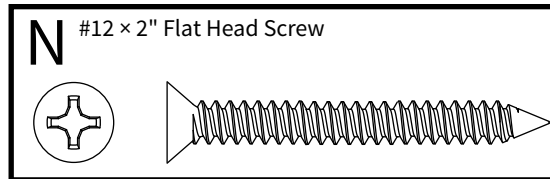

9 Attach Cable Loops and Route Cables

- 9.1 Route cables as shown, using Cable Spools (P) to take up any slack. Use the 2 Meter Leg Cable (T) for the Leg furthest from Control Box (O).
- 9.2 Attach Cable Loops (Q) to underside of worksurface using #8 × 5/8" Pan Head Screw (R) making sure to wrap the Cable Loop around the cable prior to attaching. If you do not have a Workrite worksurface, attach cable loops in convenient locations between legs or switch and the control box.

Hardware at actual size

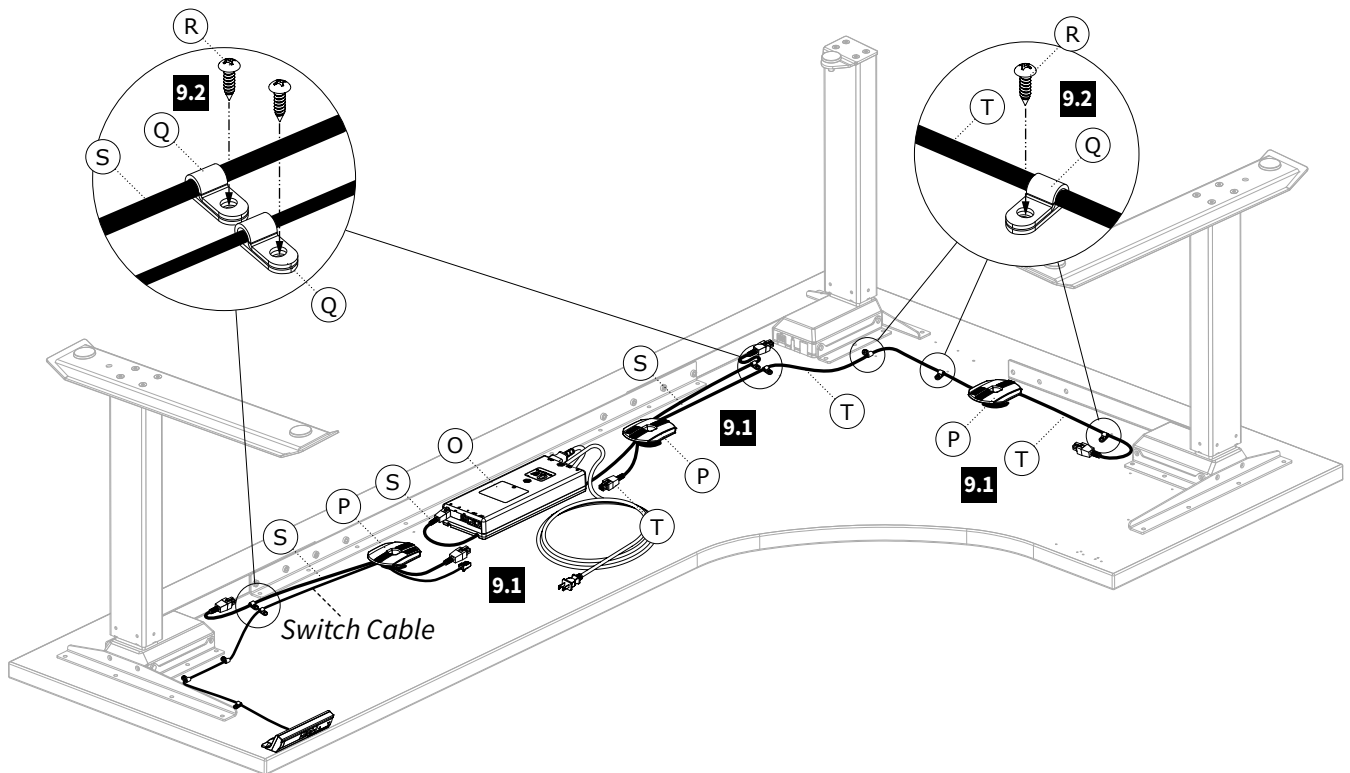
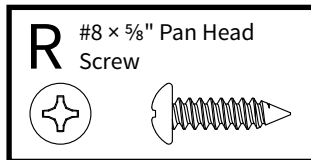

10 Connect Leg Cables, Control Cable and Power Cord to Control Box

10.1 Connect the Right Leg Cable (S) to the port on the Right Leg (A) and port “1” on the Control Box (O). Connect the Center Leg Cable (S) to the port on the Center Leg (A).

10.2 Insert the Switch Cable into port “A1” on the Control Box (O).

10.3 Connect 2 Meter Leg Cable (T) to the port on the Left Leg (A) then to port “2” on the Control Box (O)

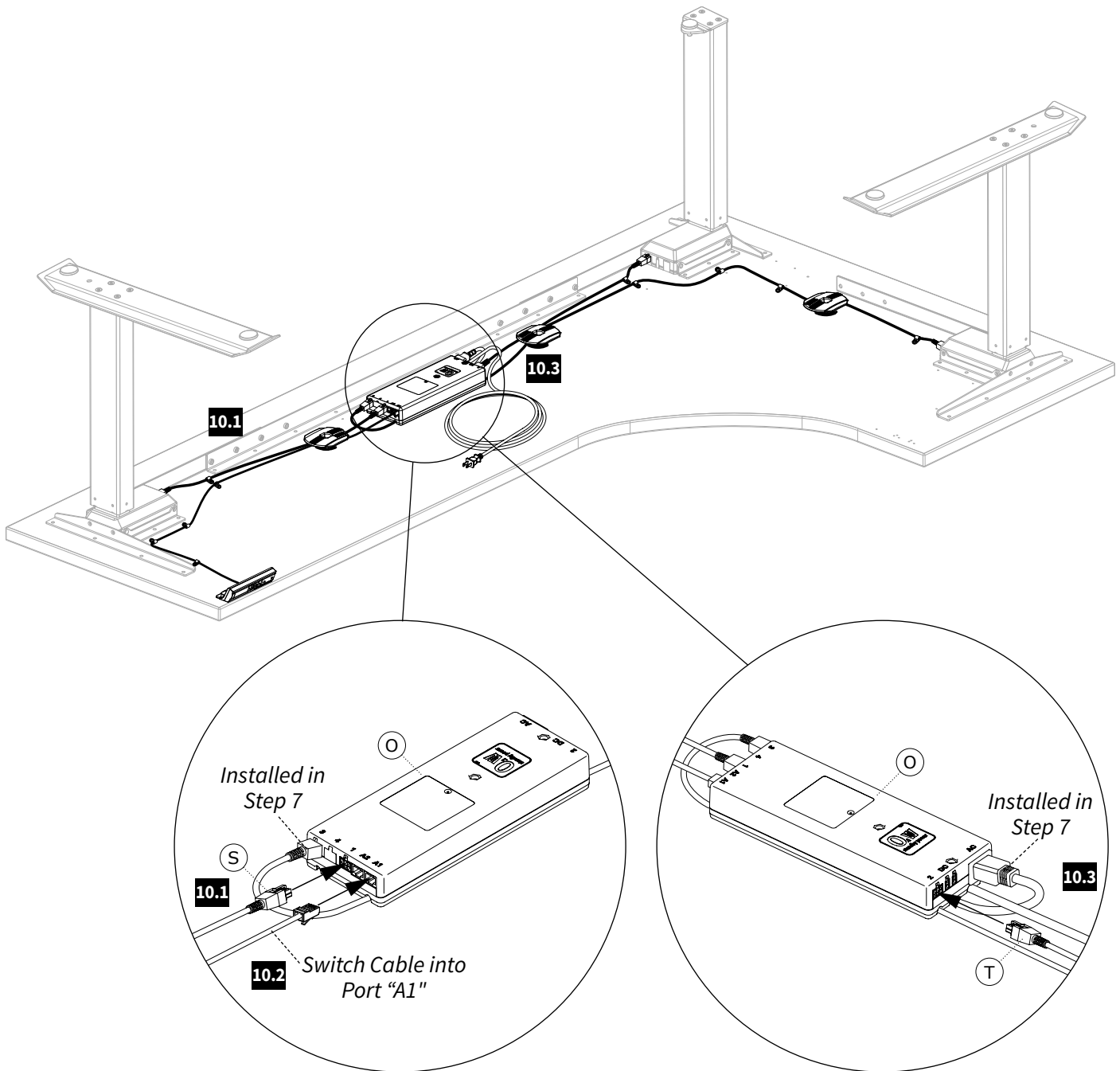

11 Put Workcenter Upright and Connect Power Cord to the Power Supply

11.1 Turn the workcenter over into an upright position.

Note: Always use at least two people to flip and move Workcenters. **Caution! Heavy!**

11.2 Plug the Power Cord (U) into the power outlet.

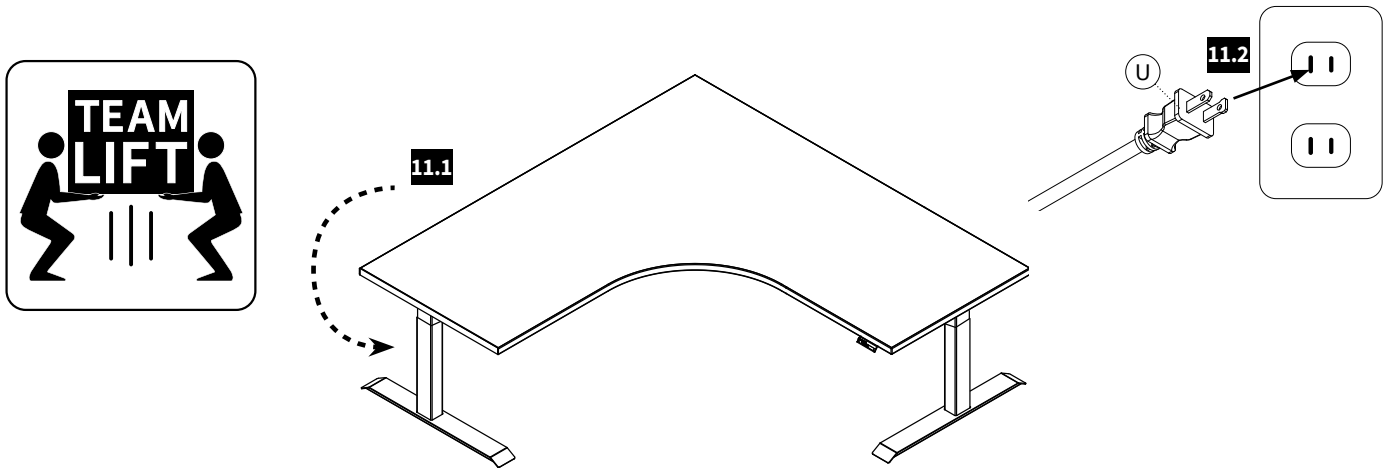

12 Adjust Feet Glides

If necessary, adjust Foot Glides (M) on the feet to level the worksurface. Unscrew to increase height, screw in to decrease height.

13 Initialize Legs

After all legs and the switch are connected, and the power cord has been plugged in, hold the **down arrow** on the switch until the legs make a short motion down and then back up. This initializes and synchronizes the workcenter legs.

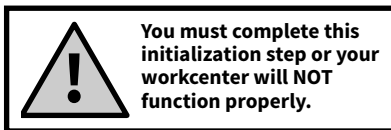

Hold down the down arrow until workcenter moves slightly upwards!

✓ Cleaning instructions

To clean the Sierra legs, apply cleaner to a soft cloth.

Suggested cleaners: Windex or Formula 409.

Do not use solvents and do not saturate or spray cleaners directly to workcenter base.

✓ Replacement Parts

Visit http://workriteergo.com/documentation/other/workrite_ergonomics_pricing_specification_guide.pdf for replacement parts.