

# Assembly & Installation Instructions: Fabric Privacy & Modesty Panels SM-FAB-XX-XXX

## Included:

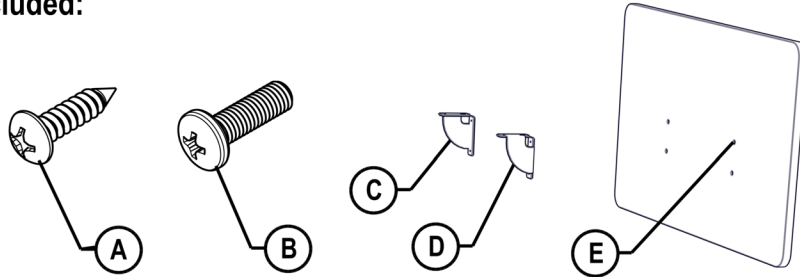

ID	Part Name	Qty
A	#10 x 3/4" Phillips Panhead Screw	4
B	#10-32 x 5/8" Phillips Screw	4
C	Left Bracket	1
D	Right Bracket	1
E	Fabric Panel SM-FAB-XX-XXX	1

**Required, Sold Separately:**  
Corresponding Worksurface

## Tools Required:

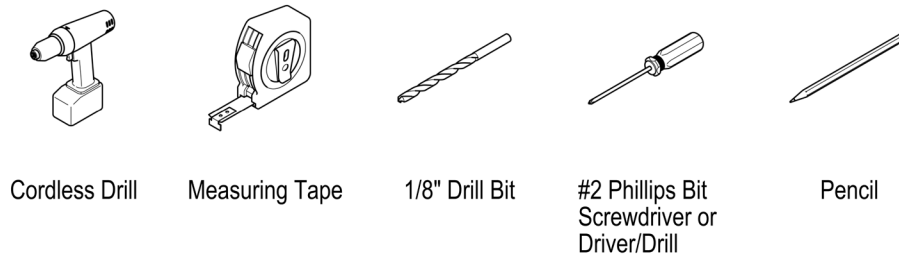

Cordless Drill

Measuring Tape

1/8" Drill Bit

#2 Phillips Bit  
Screwdriver or  
Driver/Drill

Pencil

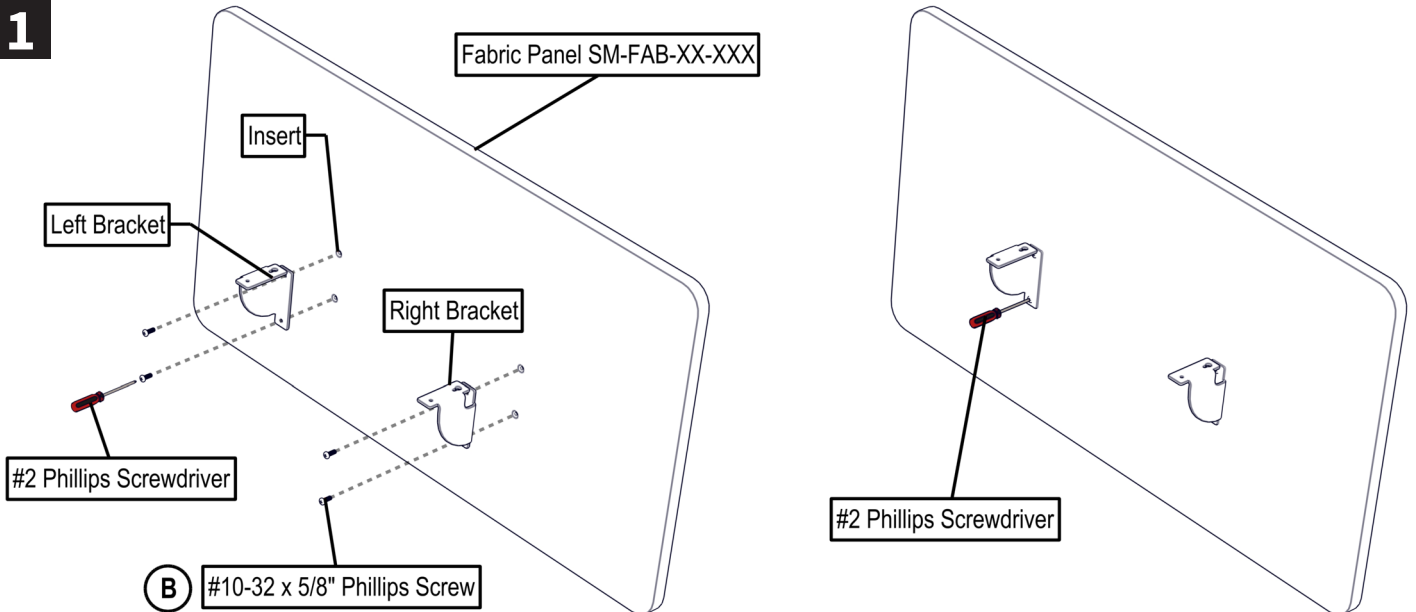

**Attach Both Brackets to Fabric Panel with Two #10-32 x 5/8" Phillips Screws Each Using #2 Phillips Screwdriver**

2

Center Panel Left to Right Behind Rear Edge of Worksurface

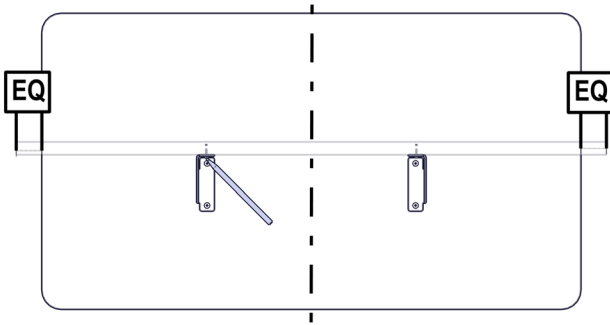

Leave a 3/8" Gap Between Panel & Worksurface For Wire Clearance

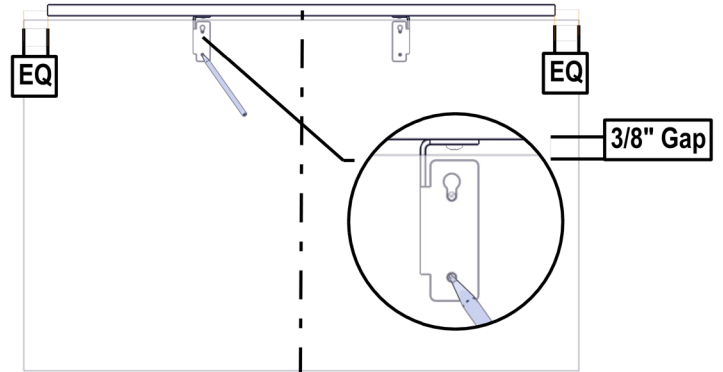

Mark All Four Locations of Pilot Holes on Under Side of Worksurface

3

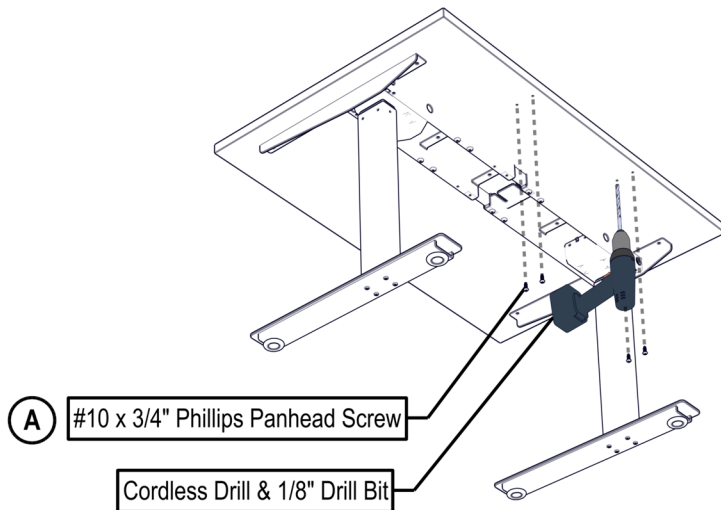

**!** Drill Four Pilot Holes From Underside of Worksurface  
DO NOT DRILL DEEPER THAN 3/4"

4

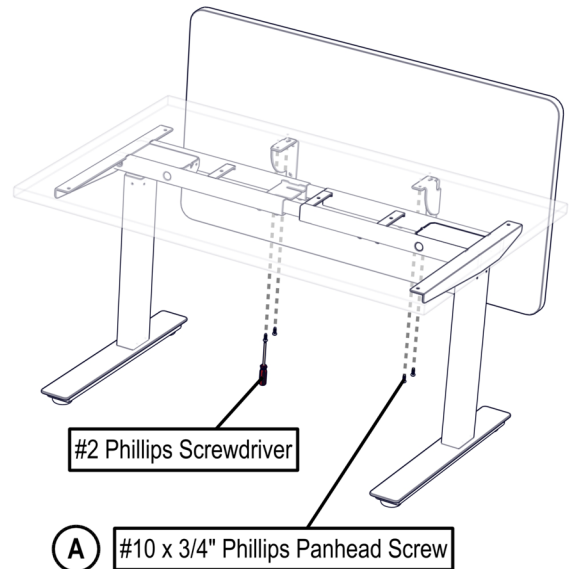

Attach Each Bracket Using Two  
#10 x 3/4" Phillips Panhead Screws