

INSTALLATION INSTRUCTIONS

Instructions d'installation
Istruzioni di installazione
Installationsanleitung

Instrucciones de instalación
Installatie-instructies
Instruções de Instalação

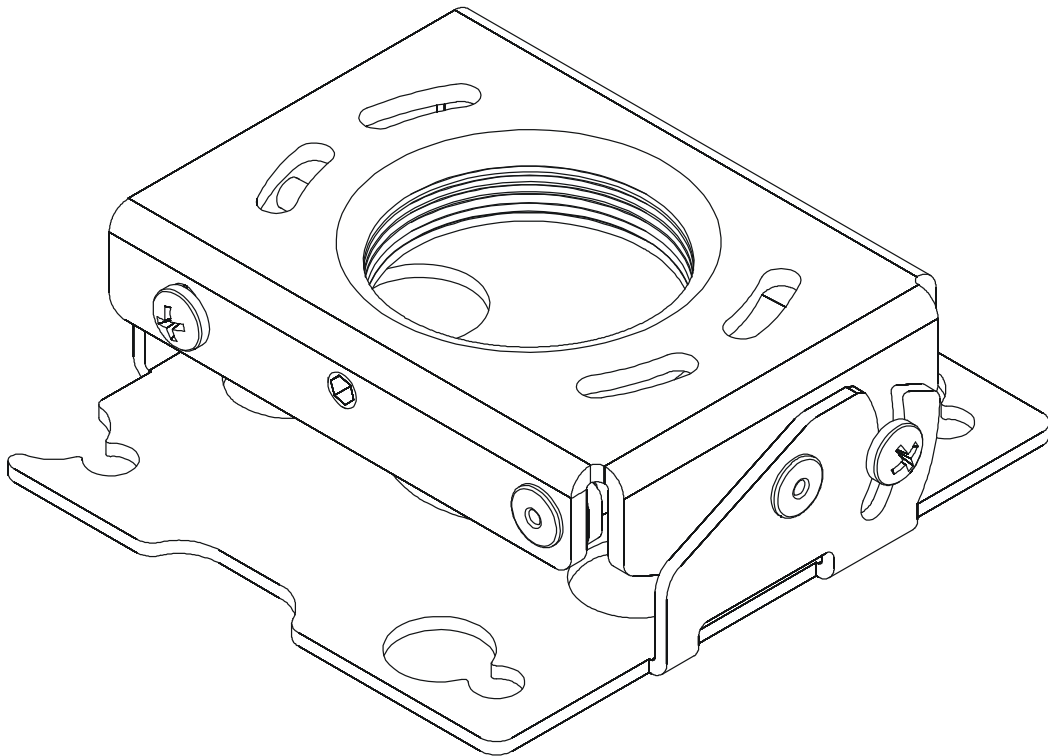

RSA Projector Mounts

DISCLAIMER

Milestone AV Technologies, and its affiliated corporations and subsidiaries (collectively, "Milestone"), intend to make this manual accurate and complete. However, Milestone makes no claim that the information contained herein covers all details, conditions or variations, nor does it provide for every possible contingency in connection with the installation or use of this product. The information contained in this document is subject to change without notice or obligation of any kind. Milestone makes no representation of warranty, expressed or implied, regarding the information contained herein. Milestone assumes no responsibility for accuracy, completeness or sufficiency of the information contained in this document.

Chief® is a registered trademark of Milestone AV Technologies. All rights reserved.

IMPORTANT WARNINGS AND CAUTIONS!

 **WARNING:** A WARNING alerts you to the possibility of serious injury or death if you do not follow the instructions.

 **CAUTION:** A CAUTION alerts you to the possibility of damage or destruction of equipment if you do not follow the corresponding instructions.

 **WARNING:** Failure to read, thoroughly understand, and follow all instructions can result in serious personal injury, damage to equipment, or voiding of factory warranty! It is the installer's responsibility to make sure all components are properly assembled and installed using the instructions provided.

 **WARNING:** Failure to provide adequate structural strength for this component can result in serious personal injury or damage to equipment! It is the installer's responsibility to make sure the structure to which this component is attached can support five times the combined weight of all equipment. Reinforce the structure as required before installing the component.

 **WARNING:** Exceeding the weight capacity can result in serious personal injury or damage to equipment! It is the installer's responsibility to make sure the combined weight of all components attached to the RSA does not exceed 25 lbs (11.34 kg).

¡AVISOS y PRECAUCIONES IMPORTANTES!

 **AVISO:** Un AVISO llama su atención sobre la posibilidad de sufrir lesiones de gravedad o incluso mortales si no sigue las instrucciones.

 **PRECAUCIÓN:** Una nota de PRECAUCIÓN llama su atención sobre la posibilidad de dañar o destruir el equipo si no sigue las instrucciones.

 **AVISO:** Si no lee, comprende perfectamente y sigue todas las instrucciones, podría causar graves daños personales y materiales o anular la garantía de fábrica. El instalador es el responsable de asegurarse de que todos los componentes están correctamente montados e instalados siguiendo las instrucciones indicadas.

 **AVISO:** Si no se proporciona la resistencia estructural adecuada para este componente, podrían provocarse graves daños personales o materiales. El instalador es el responsable de asegurarse de que la estructura a la que este componente está sujeta puede soportar cinco veces el peso combinado de todo el equipo. Refuerce la estructura según sea necesario antes de instalar el componente.

 **AVISO:** Si se excede el peso máximo, podrían causarse graves daños personales o materiales. El instalador es responsable de asegurarse de que el peso combinado de todos los componentes montados en el RSA no excede 11.34 kg.

WICHTIGE WARN- und VORSICHTSHINWEISE!

 **WARNING:** Ein WARNHINWEIS macht auf mögliche schwere oder tödliche Verletzungen aufmerksam, die bei Nichtbefolgung der Anweisungen eintreten können.

 **VORSICHT:** Ein VORSICHTSHINWEIS macht auf Schäden oder mögliche Zerstörung des Geräts aufmerksam, die bei Nichtbefolgung der Anweisungen eintreten können.

 **WARNING:** Falls nicht alle Anweisungen gelesen und gut verstanden werden, kann dies zu schweren Körperverletzungen, Schaden an den Geräten führen und die Werksgarantie nichtig machen! Der Monteur ist dafür verantwortlich, dass alle Komponenten unter Einhaltung der mitgelieferten Anweisungen korrekt zusammengebaut und eingebaut werden.

 **WARNING:** Wenn für diese Komponente keine ausreichende bauliche Tragkraft vorhanden ist, kann dies zu schweren Körperverletzungen oder Schäden an den Geräten führen! Der Installateur ist dafür verantwortlich zu überprüfen, ob die Wand, an der diese Komponente verankert wird, das Fünffache der Gesamtlast aller befestigten Geräte sicher tragen kann. Andernfalls muss die Wand verstärkt werden, bevor die Komponente angebracht wird.



WARNUNG: Wenn das zulässige Gewicht überschritten wird, kann dies zu schweren Körperverletzungen oder Schäden an den Geräten führen! Der Monteur ist dafür verantwortlich, dass das kombinierte Gewicht aller Komponenten, die am Modell RSA befestigt sind, nicht mehr als 11.34 kg beträgt.



ADVERTÊNCIAS e AVISOS IMPORTANTES!



ADVERTÊNCIA: Os alertas de ADVERTÊNCIA avisam-no para a possibilidade de ocorrência de graves lesões ou morte no caso de incumprimento das instruções.



AVISO: Os alertas de AVISO avisam-no para a possibilidade de danos ou destruição do equipamento no caso de incumprimento das instruções.



ADVERTÊNCIA: Se não ler, compreender completamente e seguir todas as instruções podem ocorrer graves lesões pessoais, danos no equipamento e a garantia de fábrica pode ser anulada! É da responsabilidade do instalador certificar-se de que todos os componentes são correctamente montados e instalados de acordo com as instruções fornecidas.



ADVERTÊNCIA: Se não for proporcionado apoio estrutural adequado a este componente podem ocorrer graves lesões pessoais ou danos no equipamento! É da responsabilidade do instalador certificar-se de que a estrutura à qual este componente é ligado pode suportar cinco vezes o peso combinado de todo o equipamento. Reforce a estrutura conforme necessário antes de instalar o componente.



ADVERTÊNCIA: Exceder a capacidade de peso pode resultar em graves lesões pessoais ou danos no equipamento! É da responsabilidade do instalador certificar-se de que o peso combinado de todos os componentes ligados ao RSA não excede 11.34 kg.



AVVERTENZE e PRECAUZIONI IMPORTANTI!



AVVERTENZA: Un'AVVERTENZA mette in guardia in merito alla possibilità di gravi infortuni, anche letali, qualora non si osservino le istruzioni.



ATTENZIONE: Un'ATTENZIONE indica la possibilità di gravi danni all'attrezzatura qualora non ci si attiene alle istruzioni al riguardo.



AVVERTENZA: La mancata comprensione e ottemperanza alle istruzioni fornite può provocare gravi lesioni personali, danni all'apparecchiatura o annullare la garanzia fornita dal produttore. Spetta all'installatore verificare che tutti i componenti siano assemblati correttamente e installati secondo le istruzioni fornite.



AVVERTENZA: Una resistenza strutturale inadeguata per questo componente può arrecare gravi infortuni o danneggiare l'apparecchiatura. È responsabilità dell'installatore verificare che la struttura alla quale è fissato il componente sostenga con sicurezza cinque volte il carico combinato di tutta l'apparecchiatura. Rinforzare la struttura secondo necessità prima di installare i componenti.



AVVERTENZA: Un peso superiore alla capacità nominale può arrecare gravi infortuni o danneggiare l'apparecchiatura. È responsabilità dell'installatore verificare che il peso totale di tutti i componenti montati sul RSA non superi 11.34 kg (25 lb).



BELANGRIJKE AANWIJZINGEN en WAARSCHUWINGEN!



WAARSCHUWING: Een WAARSCHUWING vestigt uw aandacht op de mogelijkheid van ernstig of dodelijk letsel als u de instructies niet opvolgt.



VOORZICHTIG: De aanwijzing VOORZICHTIG vestigt uw aandacht op de mogelijkheid van beschadiging of onherstelbare beschadiging van de apparatuur als u de betreffende instructies niet opvolgt.



WAARSCHUWING: Door niet alle instructies te lezen, volledig te begrijpen en op te volgen, riskeert u ernstig persoonlijk letsel, beschadiging van de apparatuur en het vervallen van de fabrieksgarantie. Degene die het product installeert is ervoor verantwoordelijk dat alle onderdelen aan de hand van de meegeleverde handleiding op de juiste wijze worden samengebouwd en gemonteerd.



WAARSCHUWING: Als u voor deze component onvoldoende constructiesterke beschikbaar stelt, riskeert u ernstig persoonlijk letsel of beschadiging van de apparatuur! Degene die de structuur monteert waaraan deze component is bevestigd, is ervoor verantwoordelijk dat deze minimaal vijf maal het gezamenlijke gewicht van alle apparatuur kan dragen. Zonodig dient u de structuur vóór de montage van de component te versterken.



WAARSCHUWING: Overschrijding van het draagvermogen kan de oorzaak zijn van ernstig persoonlijk letsel en beschadiging van de apparatuur! Degene die het product installeert is ervoor verantwoordelijk dat het totale gewicht van alle componenten die aan de RSA worden bevestigd een gewicht van 11.34 kg niet overschrijdt.



AVERTISSEMENT: Le manque de la lecture, de la compréhension et du respect total de toutes les instructions, peut entraîner des blessures corporelles graves, endommager l'équipement ou annuler la garantie d'usine. Il incombe à l'installateur de s'assurer que tous les composants sont correctement assemblés et installés à l'aide des instructions fournies.



IMPORTANT AVERTISSEMENTS et PRÉCAUTIONS!



AVERTISSEMENT: Un AVERTISSEMENT vous met en garde contre les possibilités de blessures graves ou de danger de mort si vous ne suivez pas les instructions.



AVERTISSEMENT: L'absence de l'apport d'une résistance structurelle appropriée pour ce composant peut entraîner des blessures corporelles graves ou endommager l'équipement. Il incombe à l'installateur de s'assurer que la structure à laquelle le composant est attaché peut soutenir cinq fois le poids combiné de tout l'équipement. Renforcer la structure selon les besoins avant l'installation du composant.



PRÉCAUTION: Une PRÉCAUTION vous met en garde contre les possibilités d'endommagements et de destruction de l'équipement si vous ne suivez pas les instructions correspondantes.



AVERTISSEMENT: Dépassez la capacité pondérale peut entraîner des blessures corporelles graves ou endommager l'équipement. Il incombe à l'installateur de s'assurer que le poids combiné de tous les composants attachés à RSA n'est pas supérieur à 11.34 kg (25 lb).

DIMENSIONS

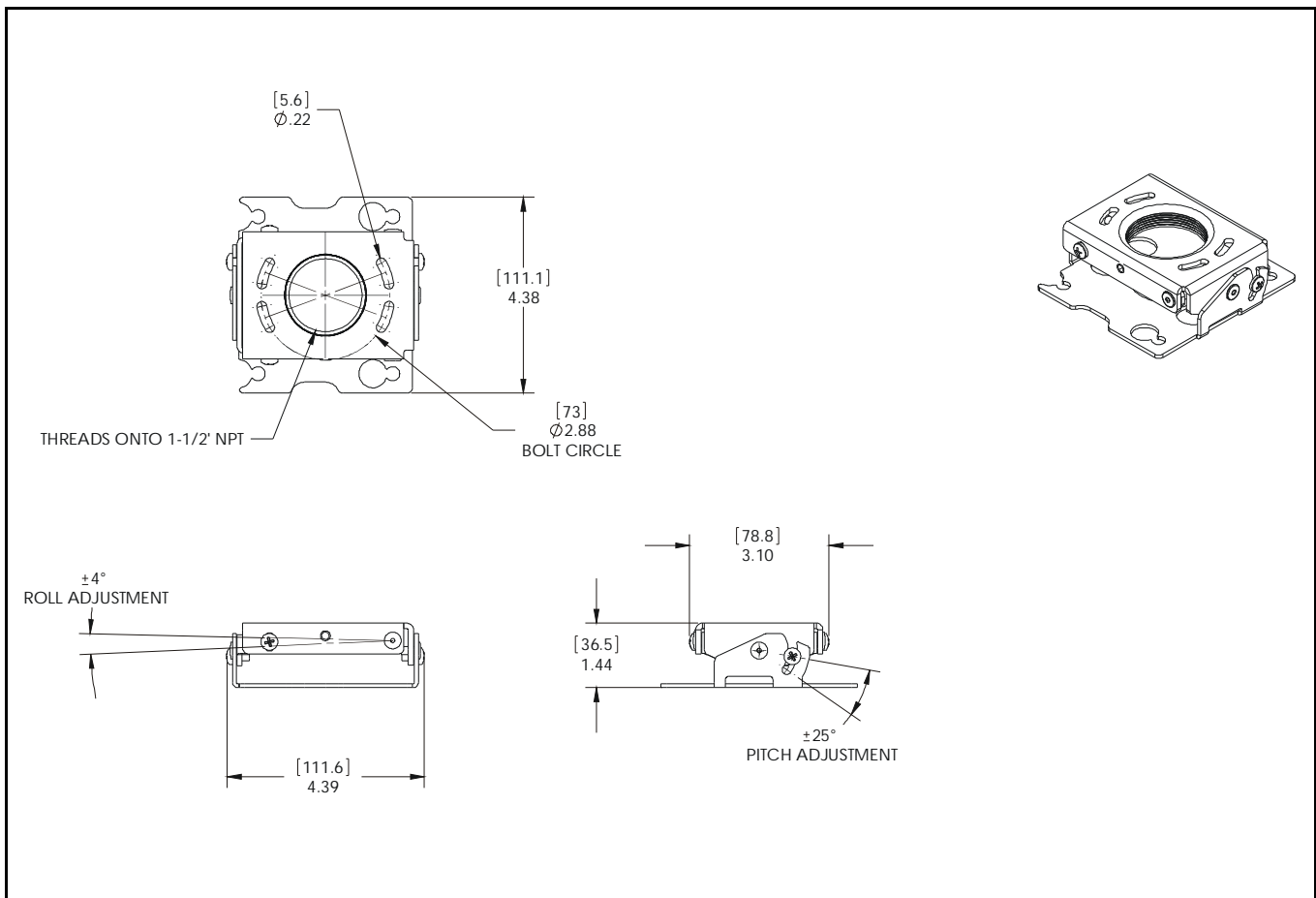

LEGEND





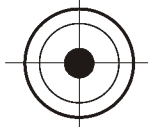

	Tighten Fastener
	Serrez les fixations
	Serrare il fissaggio
	Befestigungsteil festziehen
	Apretar elemento de fijación
	Bevestiging vastdraaien
Apertar fixador	
	Loosen Fastener
	Desserrez les fixations
	Allentare il fissaggio
	Befestigungsteil lösen
	Aflojar elemento de fijación
	Bevestiging losdraaien
Desapertar fixador	
	Phillips Screwdriver
	Tournevis à pointe cruciforme
	Cacciavite a stella
	Kreuzschlitzschraubendreher
	Destornillador Phillips
	Kruiskopschroevendraaier
Chave de fendas Phillips	
	Hex-Head Wrench
	Clé à tête hexagonale
	Chiave esagonale
	Sechskantschlüssel
	Llave de cabeza hexagonal
	Zeskantsleutel
Chave de cabeça sextavada	
	Open-Ended Wrench
	Clé à fourche
	Chiave a punte aperte
	Gabelschlüssel
	Llave de boca
	Steeksleutel
Chave de bocas	
	By Hand
	À la main
	A mano
	Von Hand
	A mano
	Met de hand
Com a mão	

	Pencil Mark
	Marquage au crayon
	Segno a matita
	Stiftmarkierung
	Marcar con lápiz
	Potloodmerkten
Marcar com lápis	
	Drill Hole
	Percez un trou
	Praticare un foro
	Bohrloch
	Perforar
	Gat boren
Fazer furo	
	Adjust
	Ajuster
	Regolare
	Einstellen
	Ajustar
	Afstellen
Ajustar	
	Remove
	Retirez
	Rimuovere
	Entfernen
	Quitar
	Verwijderen
Remover	
	Optional
	En option
	Opzionale
	Optional
	Opcional
	Optie
Opcional	
	Security Wrench
	Clé de sécurité
	Chiave di sicurezza
	Sicherheitsschlüssel
	Llave de seguridad
	Veiligheidssleutel
Chave de segurança	

	Hammer
	Martillo
	Hammer
	Martelo
	Martello
	Hamer
	Marteau

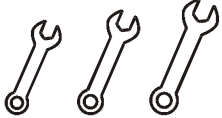
	Target of Projector
	Punto de enfoque del proyector
	Ziel des Projektors
	Mira do projector
	Punto di proiezione
	Doel van de projector
	Cible du projecteur

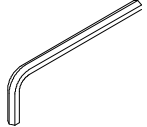
TOOLS REQUIRED FOR INSTALLATION

		
 #2	 7/16"	 7/32" (6mm) dia.
 5/32"		

PARTS



A (1)

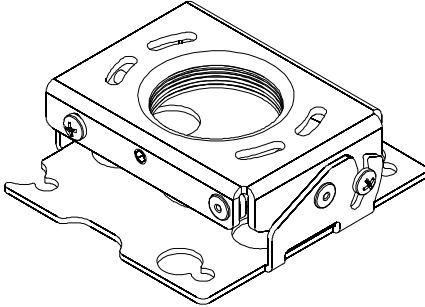

B (1)

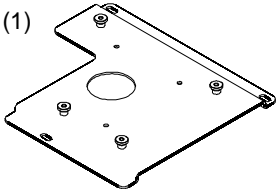

All-Points
Security
Kit

(Optional)

Example Only
(Interface bracket varies dependent on projector model)

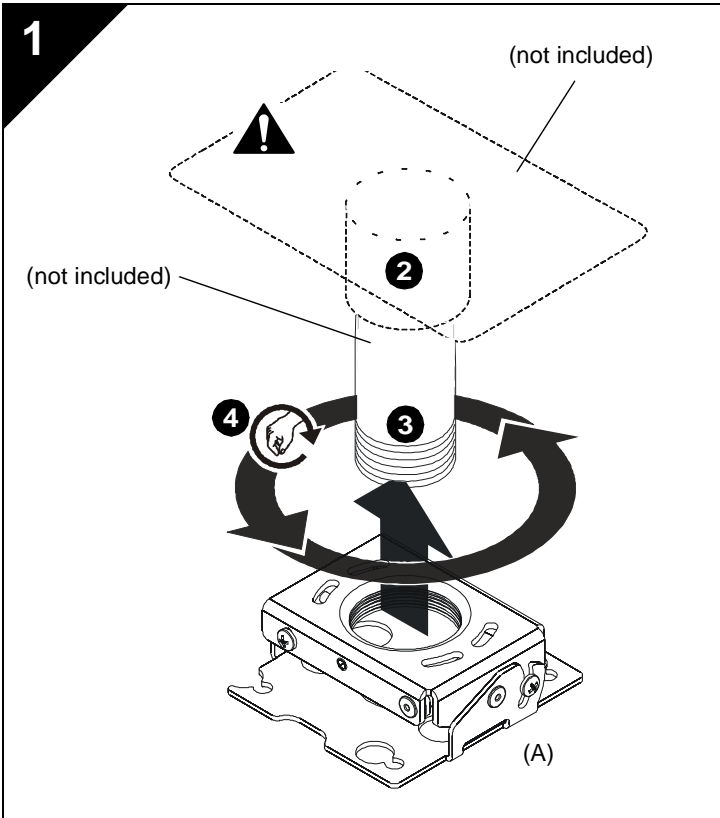

RSA INSTALLATION

Threaded Pipe Installation

1. Carefully determine required mounting location. **IMPORTANT !** : This will require knowing the lens to screen distance. See projector specifications for details on determining this distance.
2. Install Listed ceiling plate (not included) and Listed extension accessories (not included) following installation instructions provided by manufacturer.



WARNING: IMPROPER INSTALLATION CAN RESULT IN SERIOUS PERSONAL INJURY OR DAMAGE TO EQUIPMENT! Structural members **MUST** be capable of supporting five times the combined weight of all equipment being mounted.

3. Align RSA with end of NPT pipe.
4. Thread RSA up onto pipe by turning counter-clockwise until hand tight.

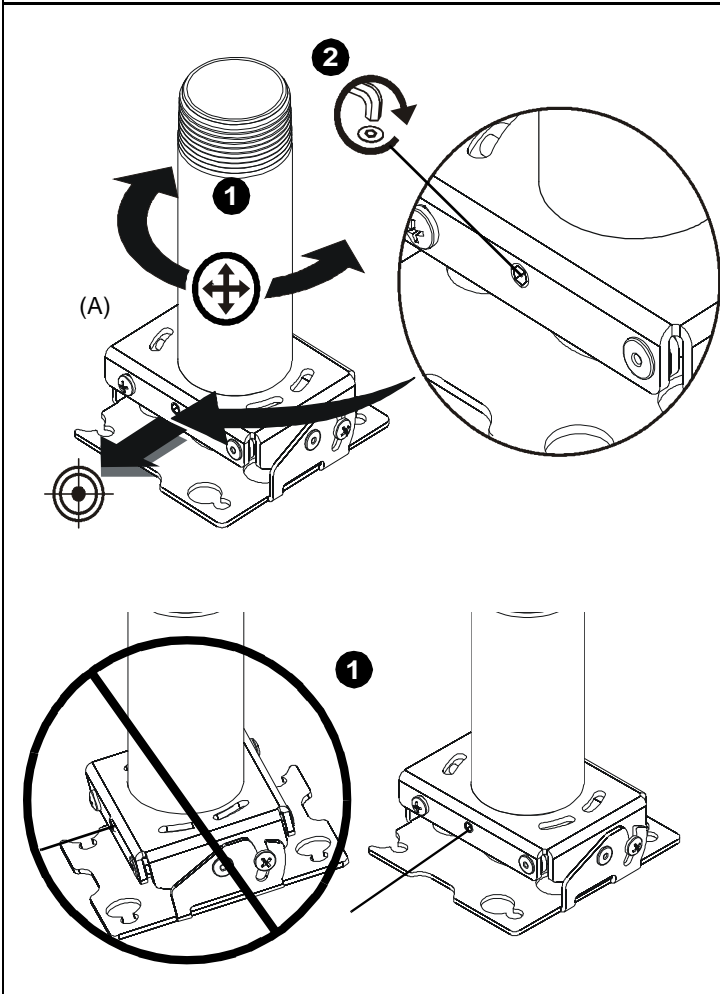

Rough Alignment of RSA

1. Turn RSA clockwise or counter-clockwise until front of mount is facing target.

IMPORTANT ! : When RSA is properly positioned, the set screw access hole should be pointing directly at target. (see bottom detail in figure at left)

2. Secure RSA to pipe by turning set screw with a 5/32" hex key until tight.



CAUTION: DO NOT OVERTIGHTEN! Overtightening of setscrew can damage threads on pipe.

INSTALLATION

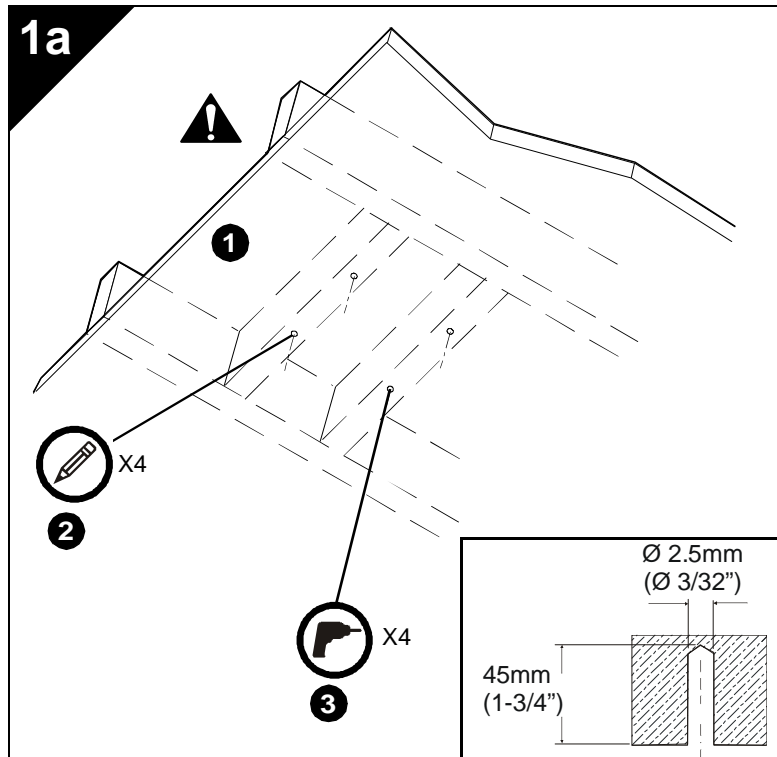

Wood Stud Installation

1. Carefully determine required mounting location.
IMPORTANT ! : This will require knowing the lens to screen distance. See projector specifications for details on determining this distance.



WARNING: IMPROPER INSTALLATION CAN RESULT IN SERIOUS PERSONAL INJURY OR DAMAGE TO EQUIPMENT! Structural members **MUST** be capable of supporting five times the combined weight of all equipment being mounted.

2. Using the RSA as a guide, mark four mounting hole locations with a pencil or similar tool.
3. Drill four 3/32" (2.5mm) dia. pilot holes to a depth of 1-3/4" (45mm) deep.

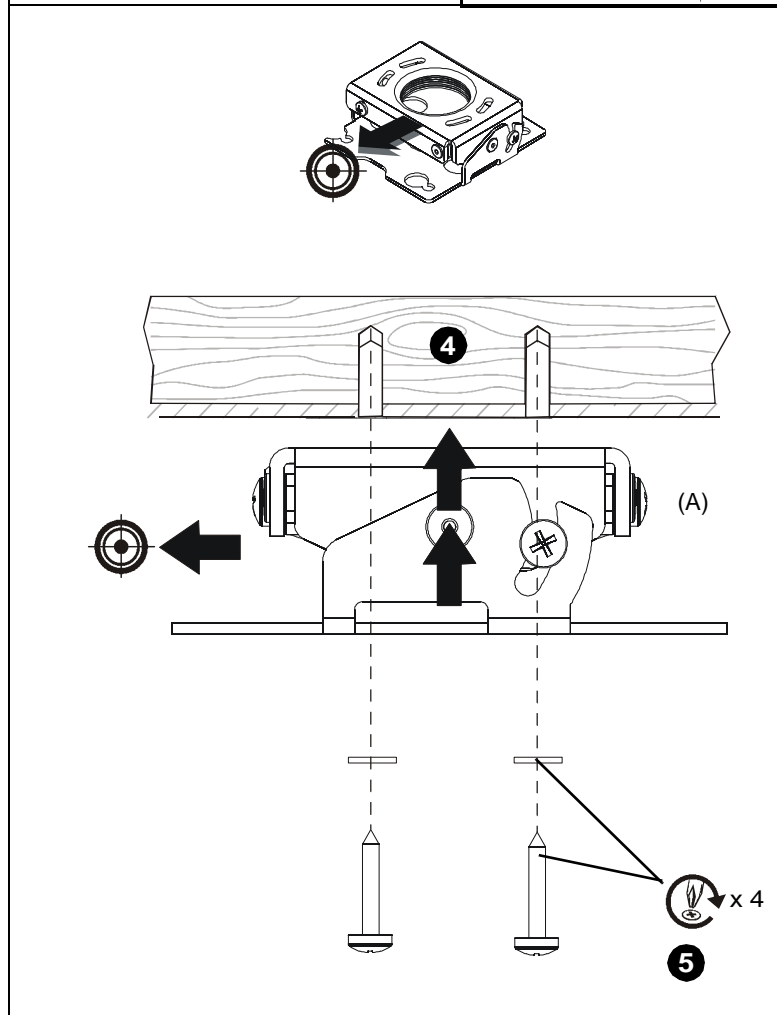

4. Align four mounting holes in RSA with four pilot holes.

IMPORTANT ! : Make sure mount is properly oriented towards target before securing to structure.

5. Secure RSA to structure using four #10 flat washers and four #10 x 3" Phillips head wood screws (not included).

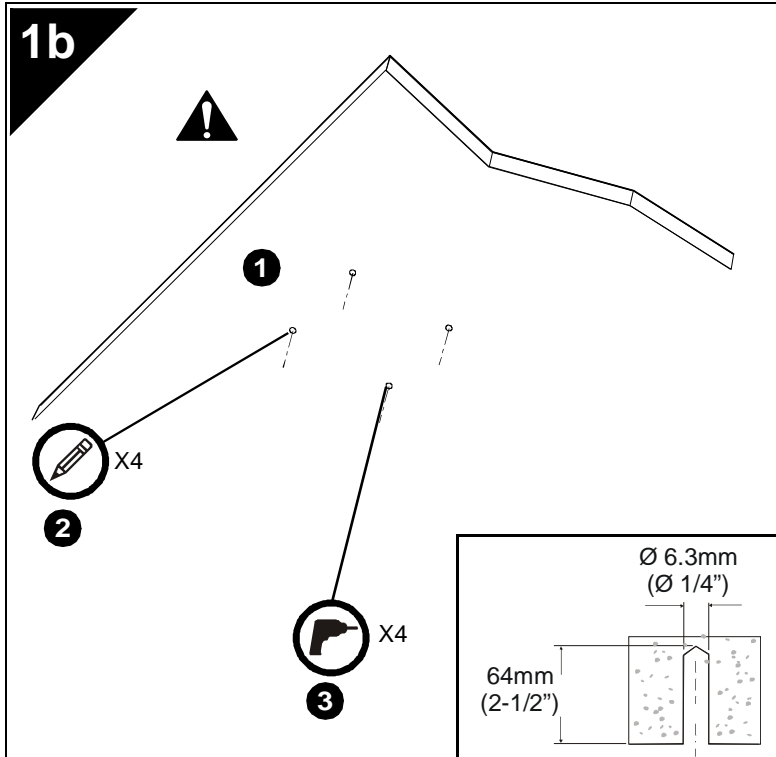

Concrete Installation

1. Determine mounting location.



WARNING: IMPROPER INSTALLATION CAN RESULT IN SERIOUS PERSONAL INJURY OR DAMAGE TO EQUIPMENT! Structural members **MUST** be capable of supporting five times the combined weight of all equipment being mounted.

2. Using the RSA as a guide, mark four mounting hole locations on ceiling using a pencil or similar tool.
3. Drill four 1/4" (6.3mm) diameter pilot holes to a depth of 2-1/2" (64mm) deep.

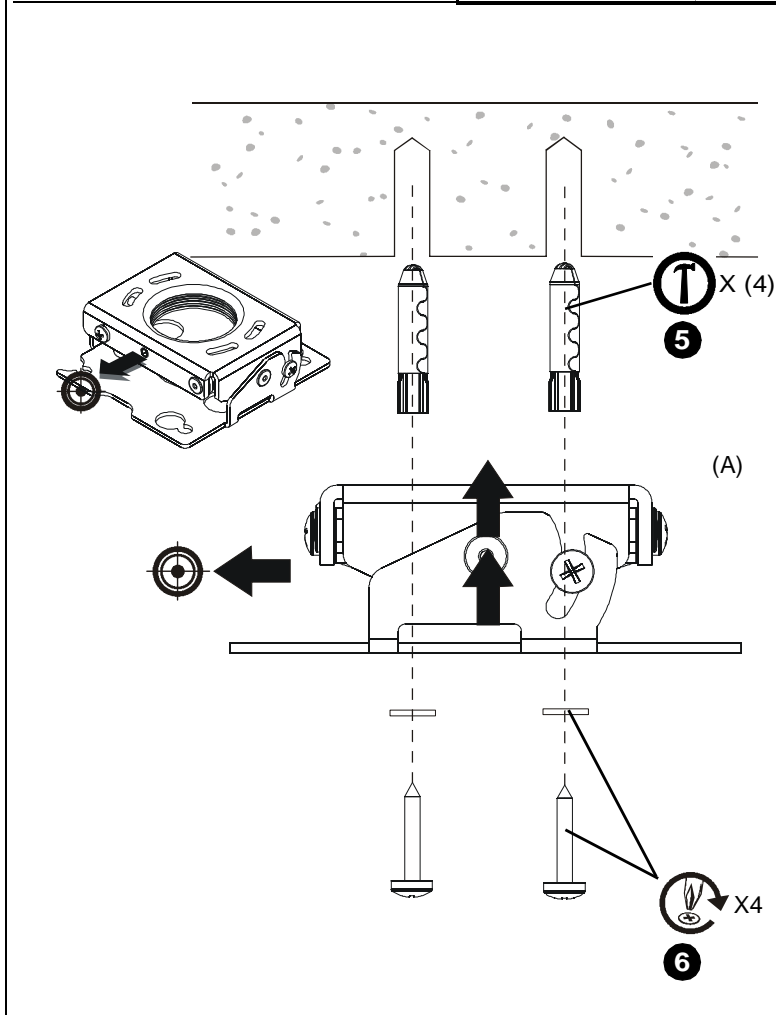

4. Align four mounting holes in RSA with four pilot holes.

IMPORTANT ! : Make sure mount is properly oriented towards target before securing to structure.

5. Install four Toggler A6 Alligator concrete anchors (not included) by inserting into pilot holes and pounding in until flush with mounting surface.
6. Secure RSA to structure using four #10 flat washers and four #10 x 3" Phillips head wood screws. (not included)

1c

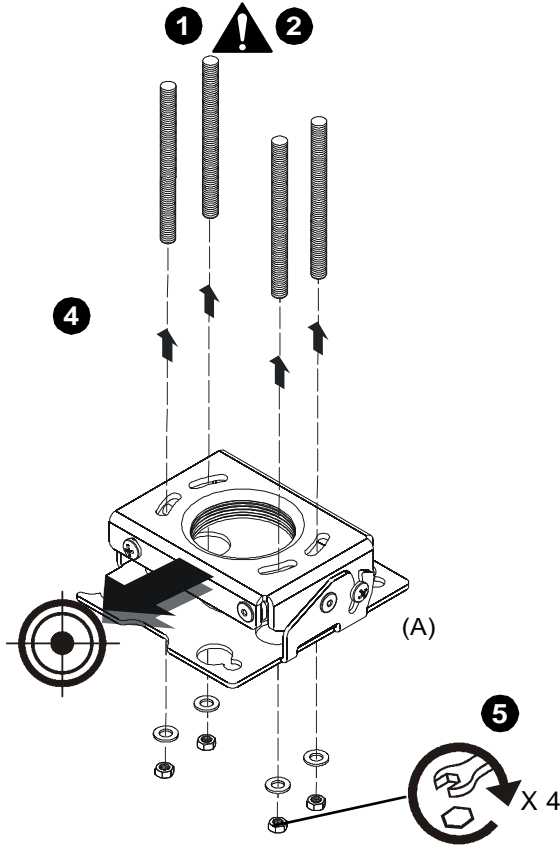

Threaded Rod Installation

The RSA can be secured to unistrut, angle or channel assembly overhead structural members (trusses or I-beams) using four #10-24 diameter threaded rods.



WARNING: IMPROPER INSTALLATION CAN RESULT IN SERIOUS PERSONAL INJURY OR DAMAGE TO EQUIPMENT! Structural members **MUST** be capable of supporting five times the combined weight of all equipment being mounted.

1. Carefully determine required mount position. **IMPORTANT ! :** This will require knowing the lens to screen distance. See projector specifications for determining this distance.

NOTE: Threaded rod and installation hardware not included.

2. Secure one end of the threaded rod to the structural member.
3. Install four #10-24 jam nuts on each threaded rod.
4. Install the RSA on the threaded rod.

NOTE: Hole in the RSA allows socket wrench access without unit disassembly.

5. Secure the RSA to the threaded rod using four #10-24 nuts.

2

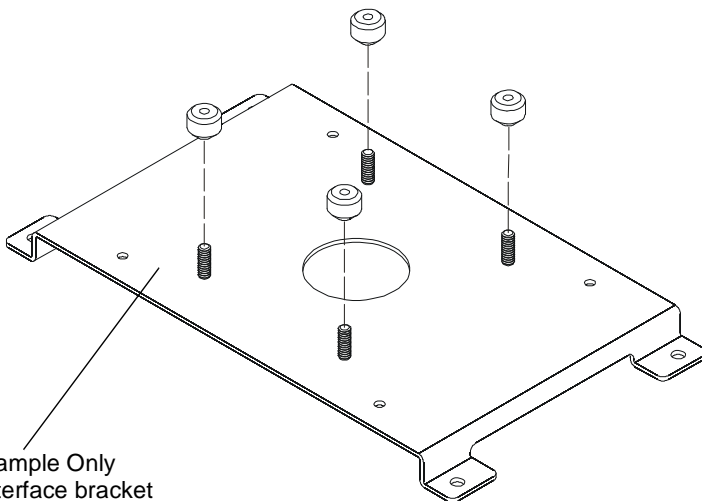

PROJECTOR INSTALLATION

IMPORTANT ! : Model RSA uses optional Chief "SSB" Series interface brackets. (See Parts drawing.)

Install Interface Bracket

1. Partially thread thumb nuts onto Phillips screws until screw end is visible in top of thumb screw.

IMPORTANT ! : DO NOT fully tighten thumb screws at this time.

Example Only
(Interface bracket varies dependent on projector model)

2a

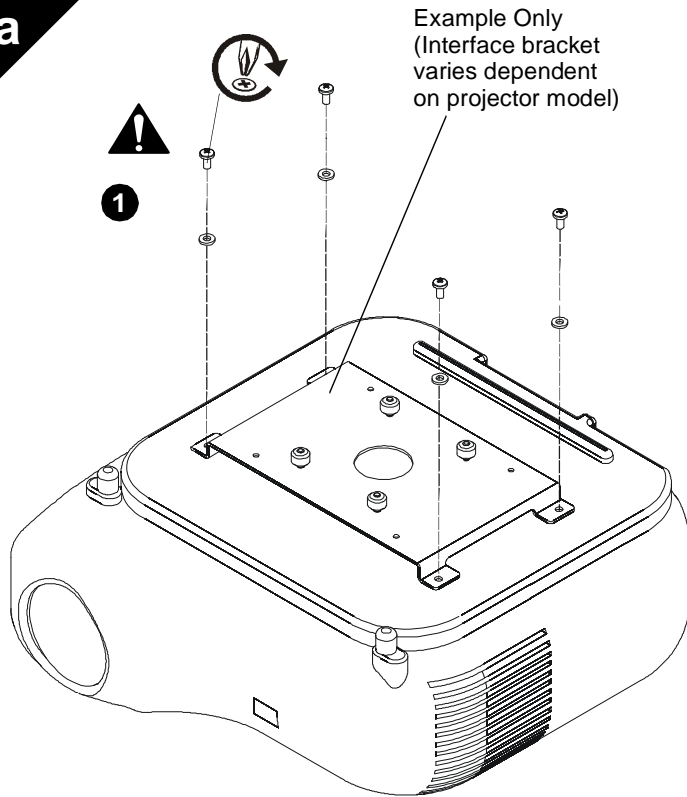

WARNING: IMPROPER INSTALLATION CAN LEAD TO PROJECTOR FALLING RESULTING IN SERIOUS PERSONAL INJURY OR DAMAGE TO EQUIPMENT. DO NOT substitute hardware. Use only the hardware provided by the manufacturer.

1. Secure interface bracket to mount using installation instructions and hardware provided with interface bracket.

NOTE: Interface brackets can be installed using the optional All-Points Security Kit included with the SSB mounting solutions.

2b

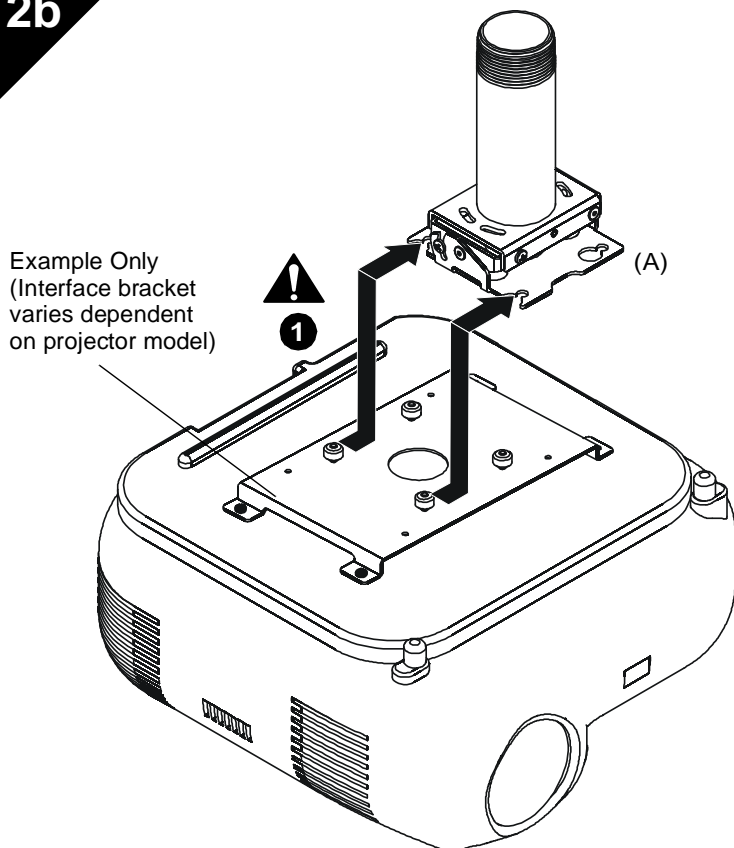

Install Projector With Interface Bracket

1. Orient projector with interface bracket as shown in figure 2b at left.
2. Lift projector so that screws with thumb nuts are aligned with mounting slots in mount base.
3. Slide projector with mounting bracket onto mounting slots in mount base until screws are seated against the back of mounting slots. See figure 2b and 2c.



WARNING: IMPROPER INSTALLATION CAN LEAD TO PROJECTOR FALLING RESULTING IN SERIOUS PERSONAL INJURY OR DAMAGE TO EQUIPMENT. Make certain mounting slots in mount base slide under thumb screws and that screws are seated in the back of slots.

2c

Example Only
(Interface bracket
varies dependent
on projector model)

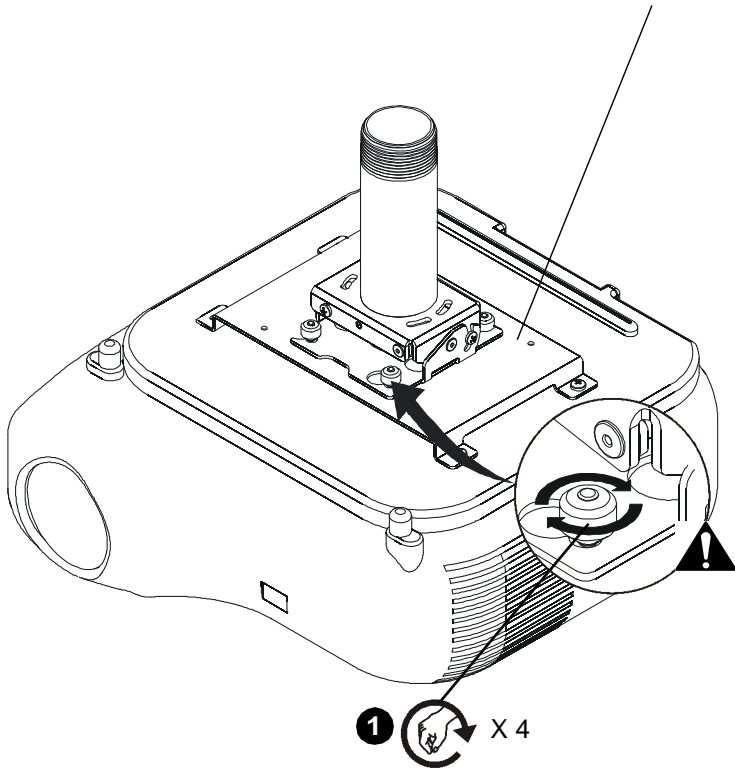

Securing Projector with Interface Bracket to Model RSA Mount.



WARNING: IMPROPER INSTALLATION CAN LEAD TO PROJECTOR FALLING RESULTING IN SERIOUS PERSONAL INJURY OR DAMAGE TO EQUIPMENT. Make certain mounting slots in mount base slide under thumb screws and that screws are seated in the back of slots.

1. Turn thumb nuts until tight to secure projector to mount.

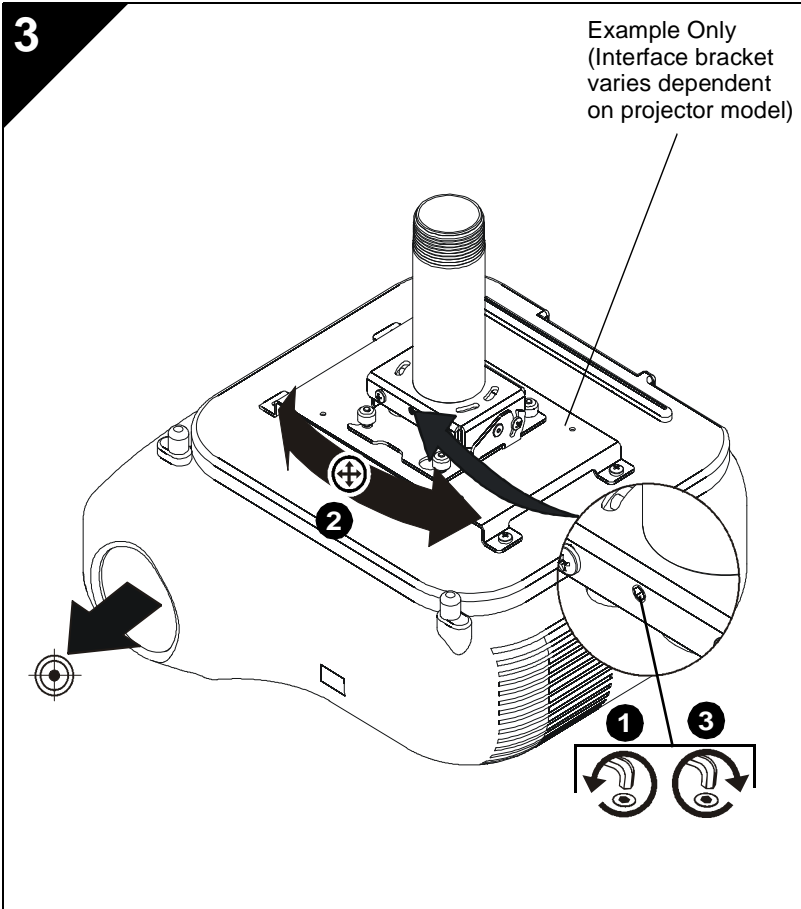

ADJUSTMENTS

YAW Adjustment

1. Loosen yaw adjustment screw using a 5/32" hex key.

NOTE: Yaw is only adjustable when attached to a threaded pipe.



WARNING: Do not turn the projector to the end of the pipe threads. The projector, interface plate and projector will fall from the pipe if it is unthreaded too far!

2. Adjust projector by turning the projector on the pipe to the desired yaw position.
3. Tighten yaw adjustment locking screw using a 5/32" hex key.

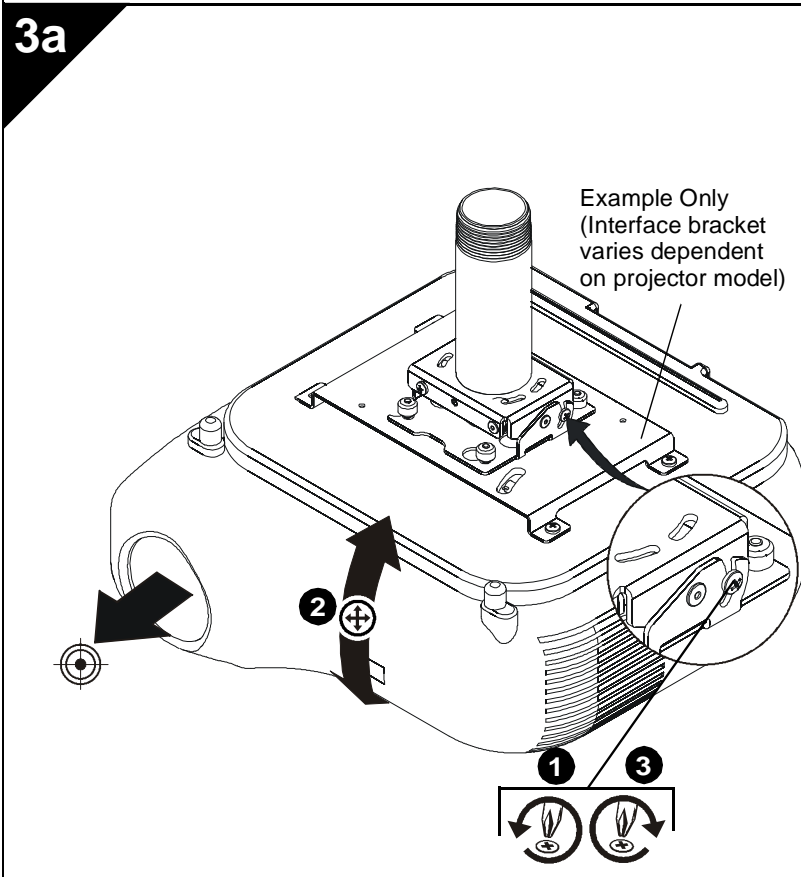

Pitch Adjustment

1. Loosen pitch adjustment locking screw on each end of the RSA projector mount using a #2 Phillips screwdriver.
2. Adjust projector angle to desired pitch.
3. Tighten pitch adjustment locking screw on each end of the RSA projector mount using a #2 Phillips screwdriver.

3b

Example Only
(Interface bracket
varies dependent
on projector model)

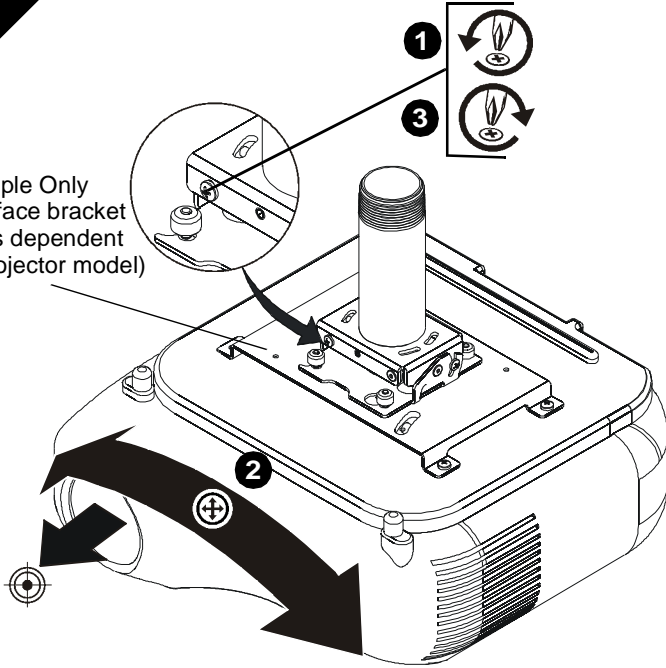

Roll Adjustment

1. Loosen roll adjustment locking screw on each side of the RSA projector mount using a #2 Phillips screwdriver.
2. Adjust projector to desired roll position.
3. Tighten roll adjustment locking screw on each side of the RSA projector mount using a #2 Phillips screwdriver.



Our Mounts. **Your Vision.**

Chief Manufacturing, a products division
of Milestone AV Technologies

8800-002005 Rev01

©2010 Milestone AV Technologies, a
Duchossois Group Company

www.chiefmfg.com

11/10

USA/International

A 8401 Eagle Creek Parkway, Savage, MN 55378

P 800.582.6480 / 952.894.6280

F 877.894.6918 / 952.894.6918

Europe

A Fellenoord 130 5611 ZB EINDHOVEN, The Netherlands

P +31 (0)40 2668620

F +31 (0)40 2668615

Asia Pacific

A Office No. 1 on 12/F, Shatin Galleria
18-24 Shan Mei Street

Fotan, Shatin, Hong Kong

P 852 2145 4099

F 852 2145 4477

