

INSTALLATION INSTRUCTIONS

CEILING PLATES

CMA-105, CMA-110, CMA-115 

The Ceiling Plates are designed for ease of installation with any height of drop ceiling. By using any length of standard NPT 1½” pipe threaded both ends, you can extend the height capabilities to meet your needs.

WARNING: IMPROPER INSTALLATION MAY RESULT IN SERIOUS PERSONAL INJURY!

When mounting Chief Manufacturing accessories, the structural system and mounting method **MUST** be capable of supporting 5 times the combined weight of the total installation. The maximum weight to be installed on the ceiling plate is 500 pounds (226.8 Kg).

Unpack and check contents:

- | | |
|---------------------------------------|---------------------------------------------|
| (1) 4” Flat Ceiling Plate CMA-105, OR | (1) 10-24 x 1/4” Button Head Security Screw |
| 8” Flat Ceiling Plate CMA-110, OR | (1) Security Spinner |
| 6” Flat Ceiling Plate CMA-115 | (1) 5/32” Security Hex Key |
| (1) 3/32” Hex Wrench | (1) #10-24 Socket Set Screw |

1. Securely install the ceiling plate to the ceiling joists. (**SEE WARNING ABOVE**)
Bolt hole spacing is shown on Figure 1 (CMA 105), Figure 2 (CMA-110) and Figure 3 (CMA-115).
2. Thread your standard NPT 1½” pipe into coupler, tighten securely.
3. Install and securely tighten the #10-24 socket set screw.
4. Follow the Ceiling Mount Instructions for mating components or mounts.

Milestone AV Technologies, Inc., and its affiliated corporations and subsidiaries (collectively, "Milestone"), intend to make this manual accurate and complete. However, Milestone makes no claim that the information contained herein covers all details, conditions or variations, nor does it provide for every possible contingency in connection with the installation or use of this product. The information contained in this document is subject to change without notice or obligation of any kind. Milestone makes no representation of warranty, expressed or implied, regarding the information contained herein. Milestone assumes no responsibility for accuracy, completeness or sufficiency of the information contained in this document.

Chief® is a trademark of Milestone AV Technologies, Inc. All rights reserved.



Chief Manufacturing, a division of Milestone AV Technologies, Inc.
8401 Eagle Creek Parkway, Savage, MN 55378

• P: 800.582.6480 / 952.894.6280 • F: 877.894.6918 / 952.894.6918

8803-000011 Rev A
©2008 Milestone AV Technologies
06/08

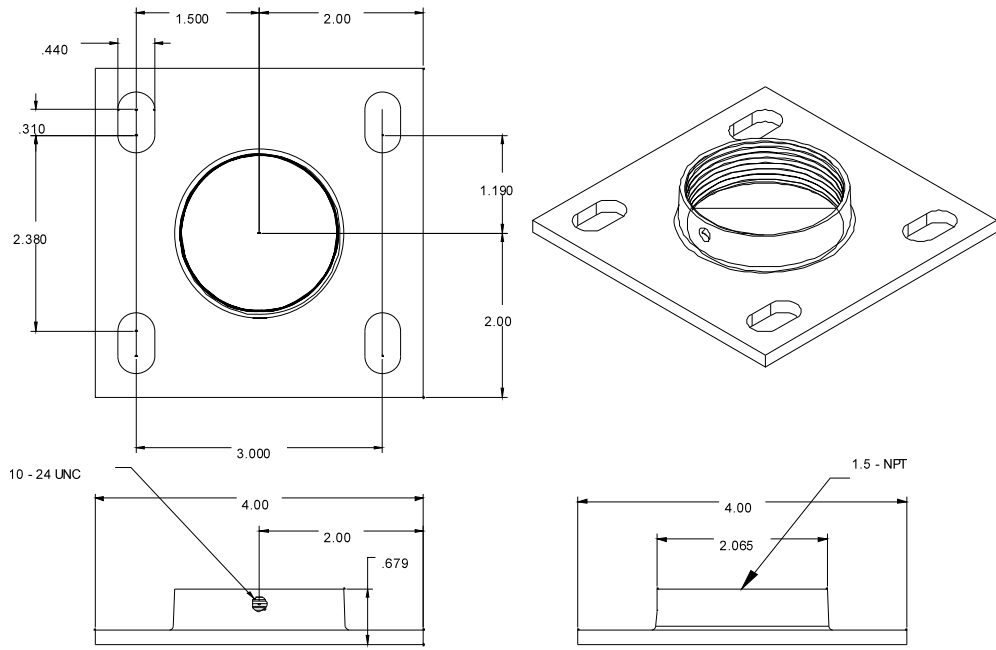

Figure 1. CMA-105 Dimensions

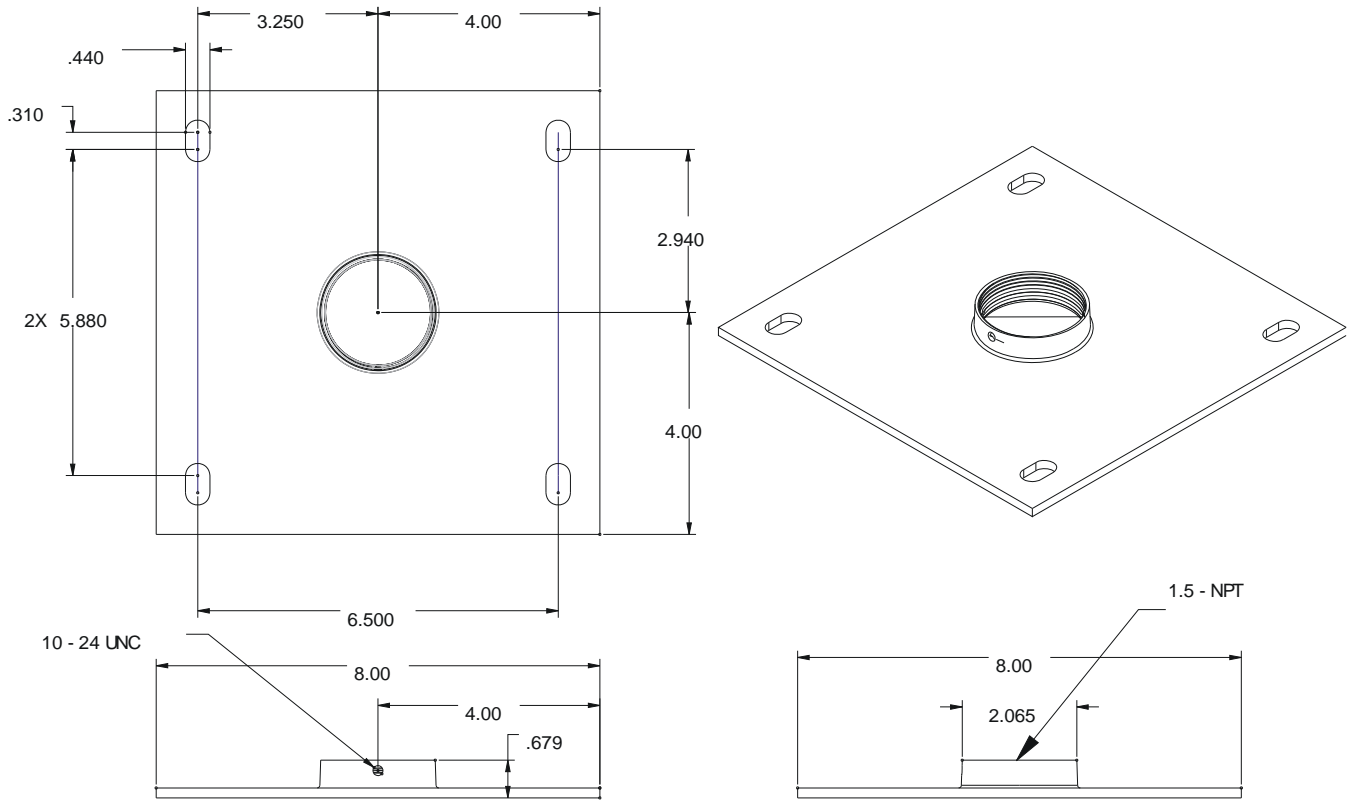

Figure 2. CMA-110 Dimensions

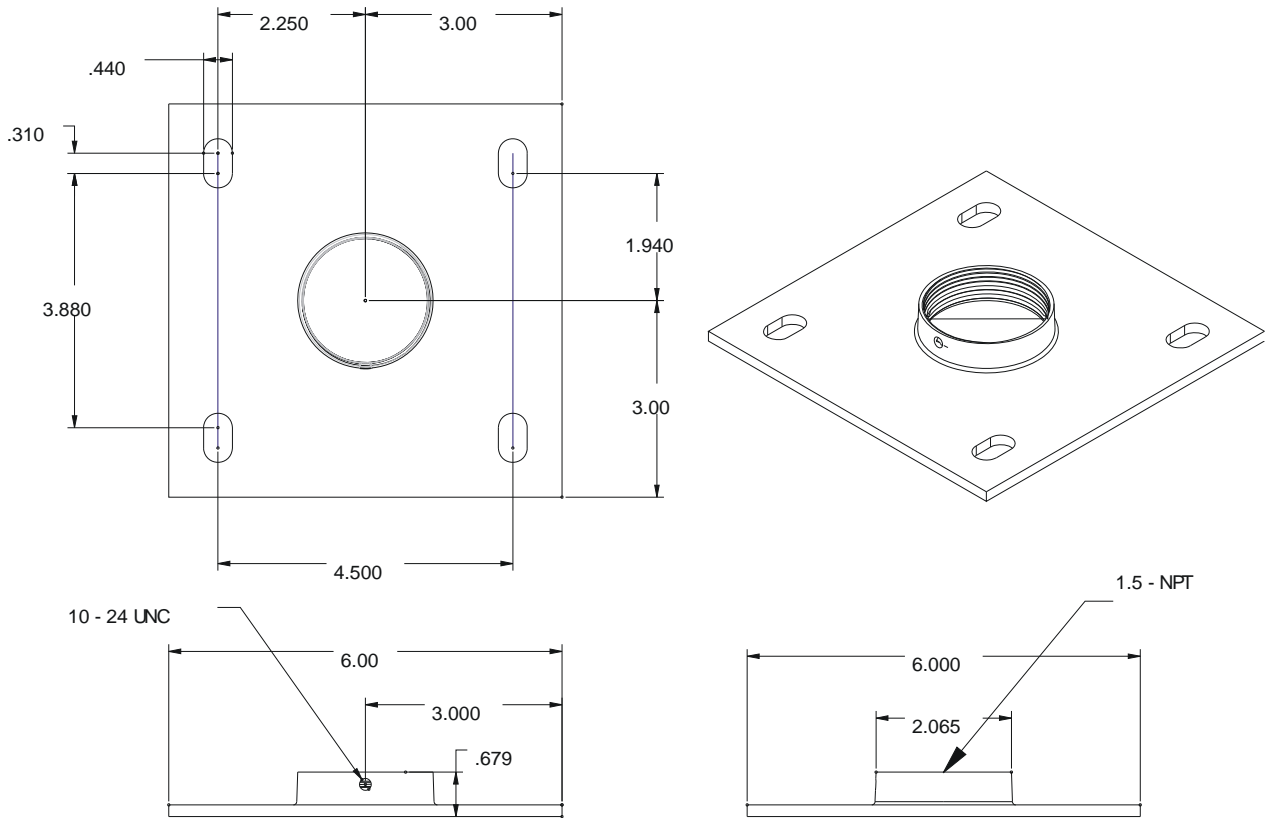

Figure 3. CMA-115 Dimensions

