

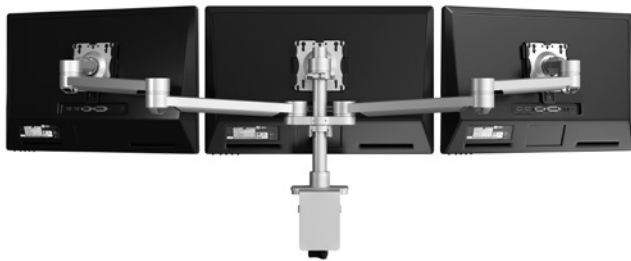

CONF-ST101-12PB-S



CONF-ST202-12PB-S



CONF-ST303-12PB-S



CONF-ST422-30PB-S



CONF-ST523-30PB-S



CONF-ST633-30PB-S

The Conform ST Series static monitor arms are designed to mount multiple monitors in many configurations. Designed for control centers, security stations, trader desks, gaming or any multiple monitor static positioning use requirement. Mount from 1 to 6 monitors up to 3 wide, single row or over under stacked configurations to meet special multiple monitor mounting needs.

MONITOR ARMS

CONFORM ST SERIES

SPECIFICATIONS

- Supports one monitors up to 16 pounds
- 2 Piece C-Clamp and Grommet Mount included
- Quick Release Adapter for quick and easy monitor mounting included
- Sturdy cast aluminum alloy and steel construction
- Maximum Monitor Actual Height: 15"
- Maximum Monitor Actual Width: 26"
- Monitor:
 - Tilt: +45°/-90°
 - Pivot: +/-180°
 - Rotation: +/-180°
- Standard VESA mount (75 mm & 100 mm)
- Monitor Rotation: 360 degrees
- Environmentally friendly powder-coat finish
- Color: Silver
- Warranty: 10 years

DIMENSIONS

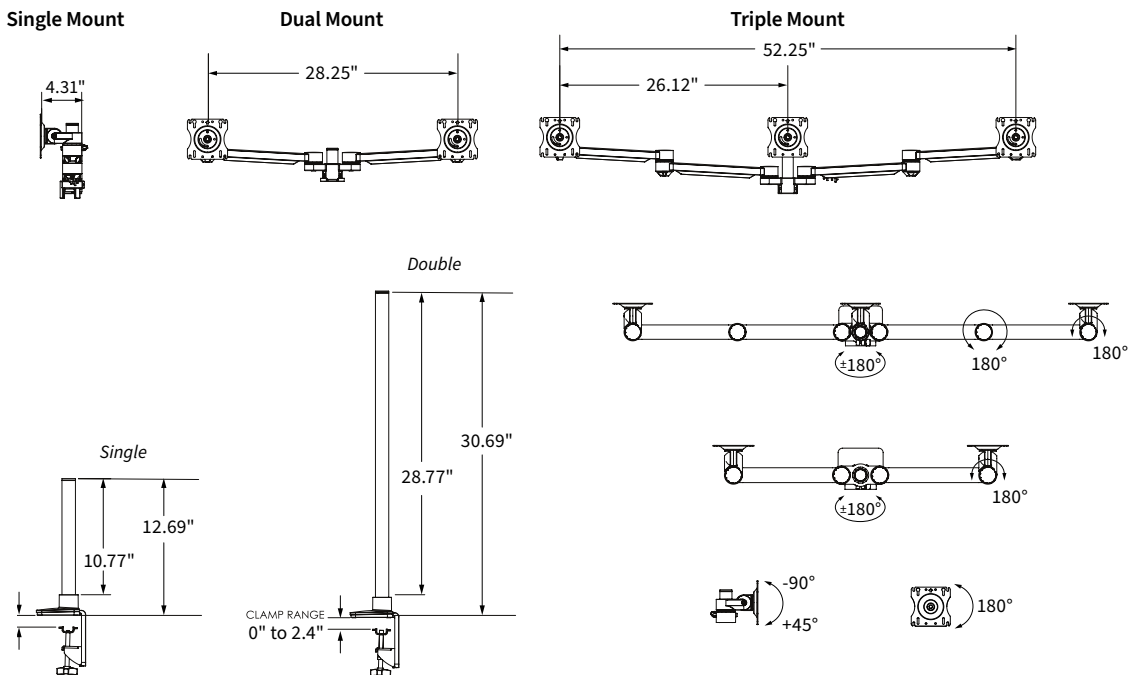

CONFIGURATIONS

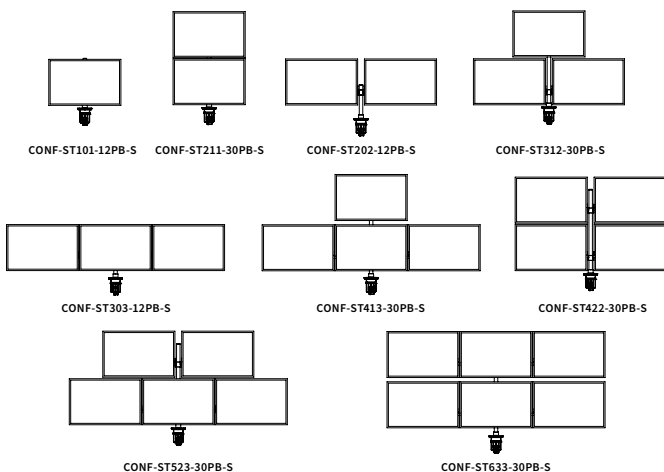

NUMBER OF MONITORS	ORIENTATION	MODEL #
1	Single	CONF-ST101-12PB-TPCG-S
2	1 over 1	CONF-ST211-30PB-TPCG-S
	Side by Side	CONF-ST202-12PB-TPCG-S
3	1 over 2	CONF-ST312-30PB-TPCG-S
	Side by Side	CONF-ST303-12PB-TPCG-S
4	1 over 3	CONF-ST413-30PB-TPCG-S
	2 over 2	CONF-ST422-30PB-TPCG-S
5	2 over 3	CONF-ST523-30PB-TPCG-S
6	3 over 3	CONF-ST633-30PB-TPCG-S

