

Assembly & Installation Instructions:

Conform Static Single Display Pole Mounted Monitor Mount

CONF-ST101-12PB-TPCG-S

Parts Included

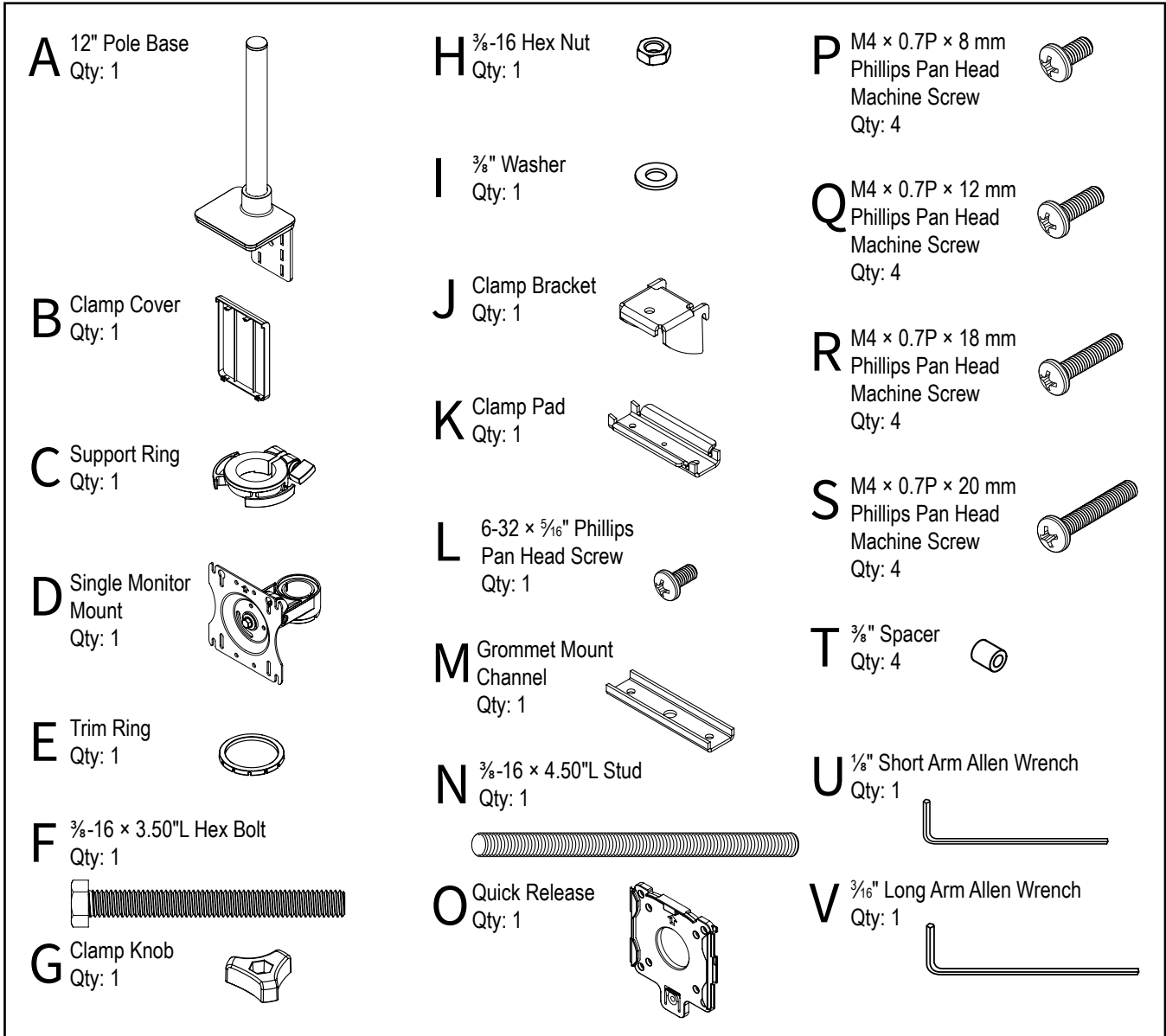

Tools Required:



Cordless Drill

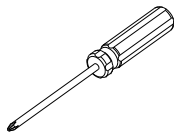

#3 Phillips Bit
Screwdriver or
Driver/Drill



3/8" pilot drill bit

1a MOUNT BASE & POLE ASSEMBLY—CLAMP MOUNT

- 1a.1** Place the Clamp Knob (G) on the $\frac{3}{8}$ -16 \times 3.50" L Hex Bolt (F)
- 1a.2** Place the $\frac{3}{8}$ Washer (I) onto the Hex Bolt (F)
- 1a.3** Install the $\frac{3}{8}$ Hex Nut (H) onto the Hex Bolt (F) and tighten to hold the knob in place
- 1a.4** Install the Bolt and Knob assembly into the Clamp Bracket (J)
- 1a.5** Attach the Clamp Pad (K) to the Hex Bolt as shown using the 6-32 \times $\frac{5}{16}$ " Phillips Pan Head Screw (L)
- 1a.6** Set the Clamp Bracket Assembly aside
- 1a.7** Place the 12" Pole Base (A) on the rear edge of your worksurface
- 1a.8** From the underside, place the clamp bracket and knob assembly into the slots of the 12" Pole Base (A). Be sure the bracket is fully seated and tighten securely
- 1a.9** Install the Clamp Cover (B) as shown

Note: Place the Clamp Bracket Assembly up as high as possible into the Pole Base to make it easy to tighten

Note: If your desk is against a wall or panel system where the bracket is not visible the Clamp Cover (B) is not needed and you can skip installing it

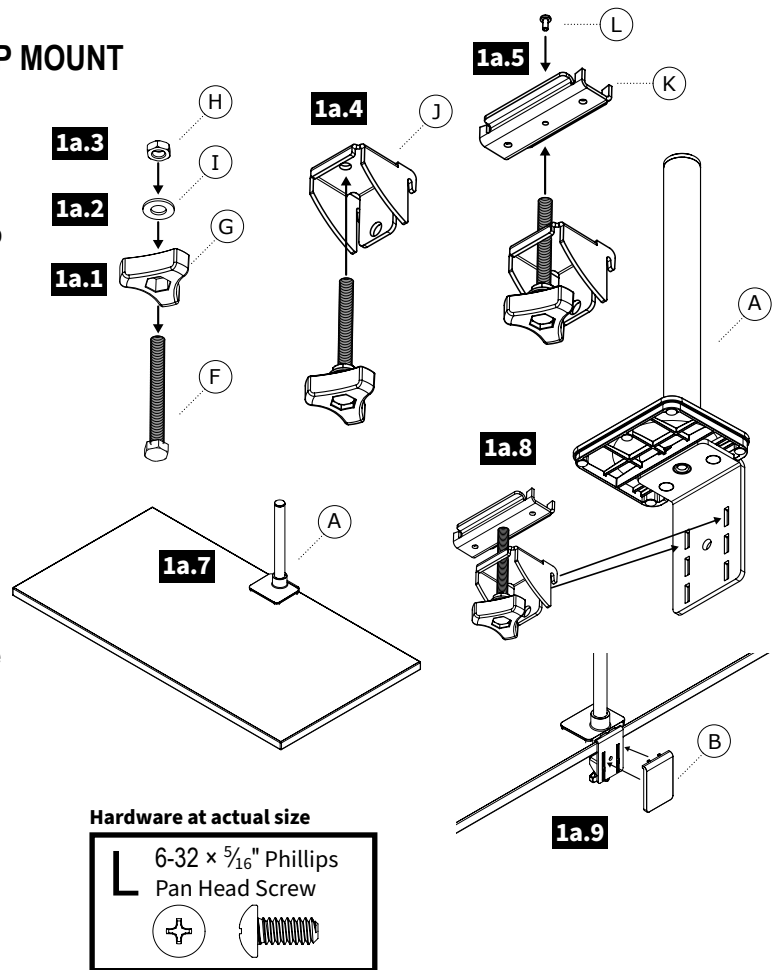

1b MOUNT BASE & POLE ASSEMBLY—GROMMET MOUNT

- 1b.1** Remove the L-Bracket from the 12" Pole Base (A) by removing the 2 screws from the base using a #3 Phillips screwdriver. Set the L-bracket aside
- 1b.2** Install the $\frac{3}{8}$ -16 \times 4.50" L Stud (N) into the base at least 8 full turns as shown
- 1b.3** Place the Pole Base & Stud into the grommet hole location for attaching to your desk
- 1b.4** From the underside, place the Grommet Mount Channel (M) onto the Stud (N) with the "U" facing up as shown. Place the $\frac{3}{8}$ Washer (I) and the $\frac{3}{8}$ -16 Hex Nut (H) onto the Stud (N) and tighten securely

Note: If there is no grommet location in your desk you can drill a hole as small as $\frac{3}{8}$ " using a power drill and drill bit or you can use a hole saw and drill a larger hole up to 3" diameter to install the grommet mount option

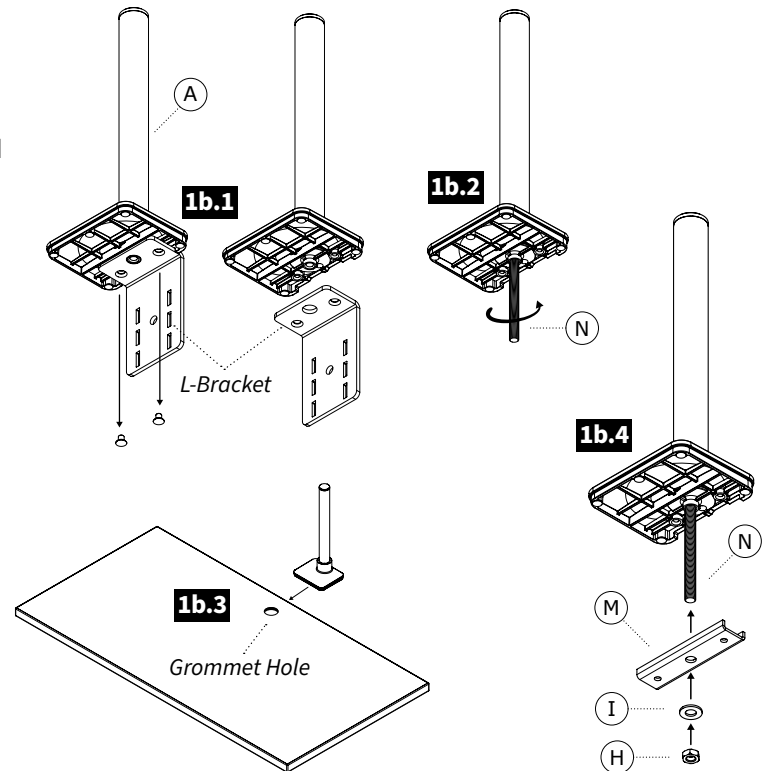

2 ATTACH SINGLE MONITOR MOUNT ONTO POLE

- 2.1 Place the Support Ring (C) **smooth side facing up** onto the Pole (A), tighten the knob to lock in place
- 2.2 Slide the Single Monitor Mount (D) onto the Pole (A) as shown
- 2.3 Place the Trim Ring (E) onto the pole and into the Single Monitor Mount (D)

Note: Height may need to be adjusted later after the monitor is installed

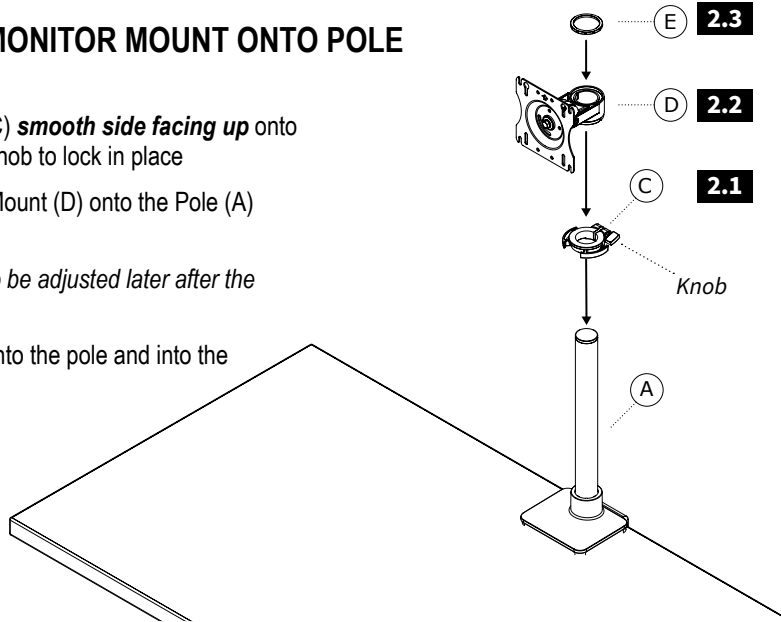

3 ATTACH THE QUICK RELEASE BRACKET & INSTALL THE MONITOR

Note: Using the Quick Release Mount is optional. Your monitor can be attached directly to the VESA plate of the monitor mount if desired

- 3.1 Locate the VESA Mount Pattern on the back of your monitor
- 3.2 Mount the Quick Release (O) to the VESA mount on your monitor as shown with four (4) M4 Screws either (P), (Q), (R) or (S) and tighten securely
- 3.3 Aligning the Monitor with Quick Release onto the VESA Plate and then sliding down to lock in place as shown

Note: In some cases, the VESA mounting pattern is hidden by a removable cover or the monitor base. These must be removed to install the Quick Release or mount the monitor

Note: Always use the shortest screws possible to avoid damaging the display by using screws that are too long

Note: In some case your monitor may require the use of the 3/8" Spacers (T) to allow proper installation of the Quick Release (O)

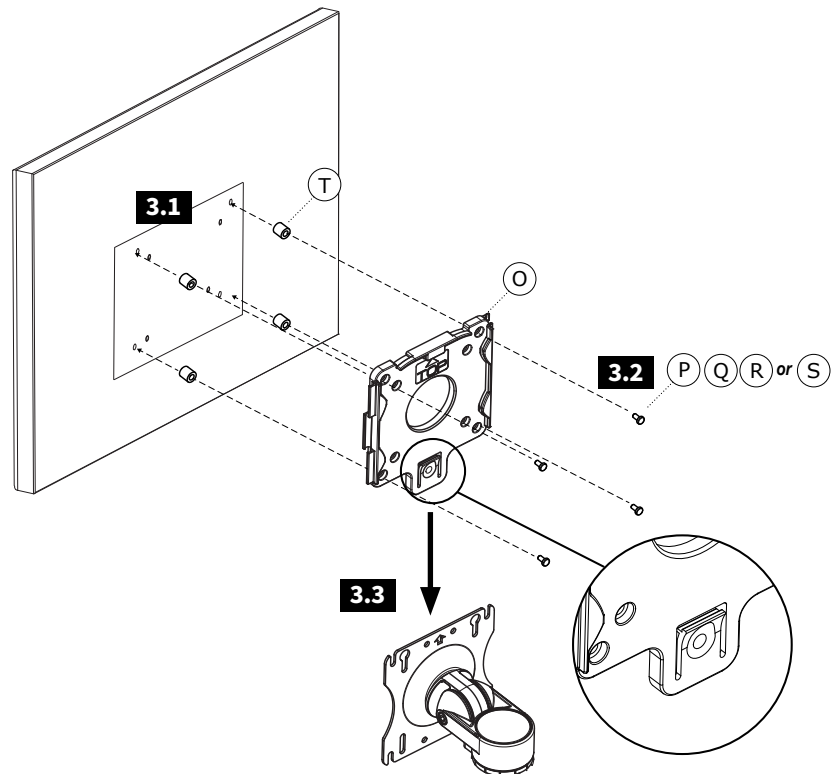

4 CABLE MANAGEMENT

- 4.1** Place monitor cables into the cable retainers of the Pole support ring

Note: Make sure there is slack in the cables that allows movement to tilt and rotate the monitor without binding

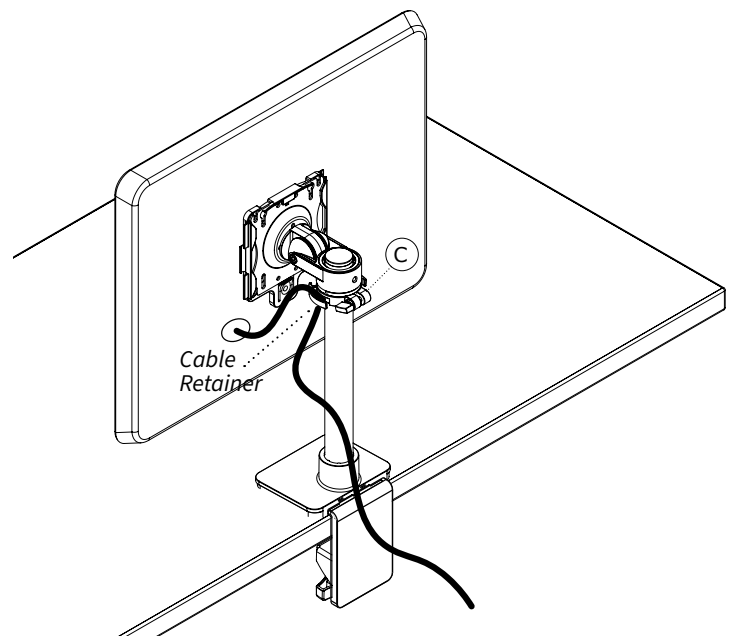

5 ADJUSTING MONITOR HEIGHT

- 5.1** Lift the monitor and mount off the Support Ring (C)
- 5.2** Loosen the knob and raise or lower the ring to the desired height and re-tighten
- 5.3** Lower the monitor mount and monitor back onto the support ring

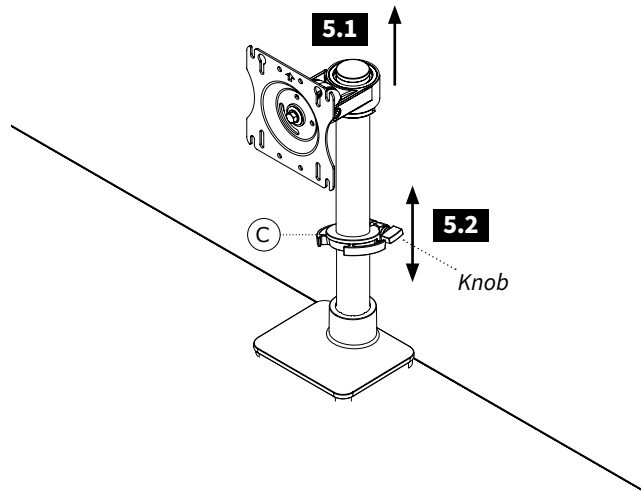

6 ADJUSTING MONITOR TILT

- 6.1** Locate the tilt adjustment bolt on the Monitor Mount
- 6.2** If the monitor tilt is too difficult to tilt loosen the tilt adjustment bolt using the $\frac{3}{16}$ " Long Allen Wrench (V) until the monitor is easy to tilt but still holds in position after adjustments are made (do not over loosen)
- 6.3** If the monitor drops or is not holding tilt, tighten the tilt adjustment bolt using the $\frac{3}{16}$ " Long Allen Wrench (V) until the monitor holds tilt but still allows tilt adjustments to be made easily (do not over tighten)

