

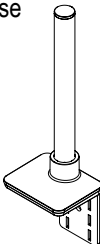









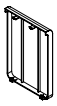

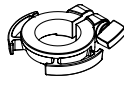

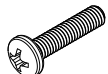
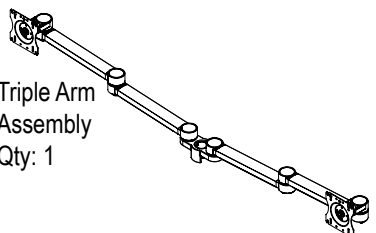
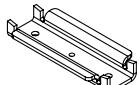
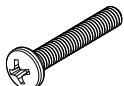
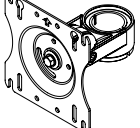
Assembly & Installation Instructions:

Conform Static 3 Display 1 by 1 by 1 Monitor Mount

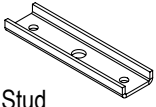
CONF-ST303-12PB-TPCG-S

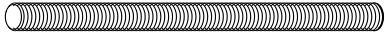
Parts Included

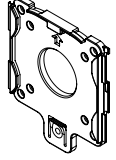
<p>A 12" Pole Base Qty: 1</p> 	<p>H Clamp Knob Qty: 1</p> 	<p>Q M4 × 0.7P × 8 mm Phillips Pan Head Machine Screw Qty: 12</p> 
<p>B Clamp Cover Qty: 1</p> 	<p>I 3/8-16 Hex Nut Qty: 1</p> 	<p>R M4 × 0.7P × 12 mm Phillips Pan Head Machine Screw Qty: 12</p> 
<p>C Support Ring Qty: 2</p> 	<p>J 3/8" Washer Qty: 1</p> 	<p>S M4 × 0.7P × 18 mm Phillips Pan Head Machine Screw Qty: 12</p> 
<p>D Triple Arm Assembly Qty: 1</p> 	<p>L Clamp Pad Qty: 1</p> 	<p>T M4 × 0.7P × 20 mm Phillips Pan Head Machine Screw Qty: 12</p> 
<p>E Single Monitor Mount Qty: 1</p> 	<p>M 6-32 × 5/16" Phillips Pan Head Screw Qty: 1</p> 	<p>U 3/8" Spacer Qty: 12</p> 
<p>F Trim Ring Qty: 2</p> 	<p>N Grommet Mount Channel Qty: 1</p> 	<p>V 1/8" Short Arm Allen Wrench Qty: 1</p> 
<p>G 3/8-16 × 3.50"L Hex Bolt Qty: 1</p> 	<p>O 3/8-16 × 4.50"L Stud Qty: 1</p> 	<p>W 3/16" Long Arm Allen Wrench Qty: 1</p> 
<p>P Quick Release Qty: 3</p> 		

Tools Required:



Cordless Drill

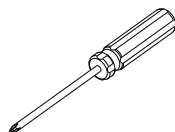

#3 Phillips Bit
Screwdriver or
Driver/Drill

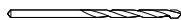

3/8" pilot drill bit

1a MOUNT BASE & POLE ASSEMBLY—CLAMP MOUNT

- 1a.1** Place the Clamp Knob (H) on the $\frac{3}{8}$ -16 \times 3.50"L Hex Bolt (G)
- 1a.2** Place the $\frac{3}{8}$ Washer (J) onto the Hex Bolt (G)
- 1a.3** Install the $\frac{3}{8}$ Hex Nut (I) onto the Hex Bolt (G) and tighten to hold the knob in place
- 1a.4** Install the Bolt and Knob assembly into the Clamp Bracket (K)
- 1a.5** Attach the Clamp Pad (L) to the Hex Bolt as shown using the 6-32 \times $\frac{5}{16}$ " Phillips Pan Head Screw (M)

- 1a.6** Set the Clamp Bracket Assembly aside
- 1a.7** Place the 12" Pole Base Assembly (A) on the rear edge of your worksurface
- 1a.8** From the underside, place the clamp bracket and knob assembly into the slots of the 12" Pole Base (A). Be sure the bracket is fully seated and tighten securely

Note: Place the Clamp Bracket Assembly up as high as possible into the Pole Base to make it easy to tighten

- 1a.9** Install the Clamp Cover (B) as shown

Note: If your desk is against a wall or panel system where the bracket is not visible the Clamp Cover (B) is not needed and you can skip installing it

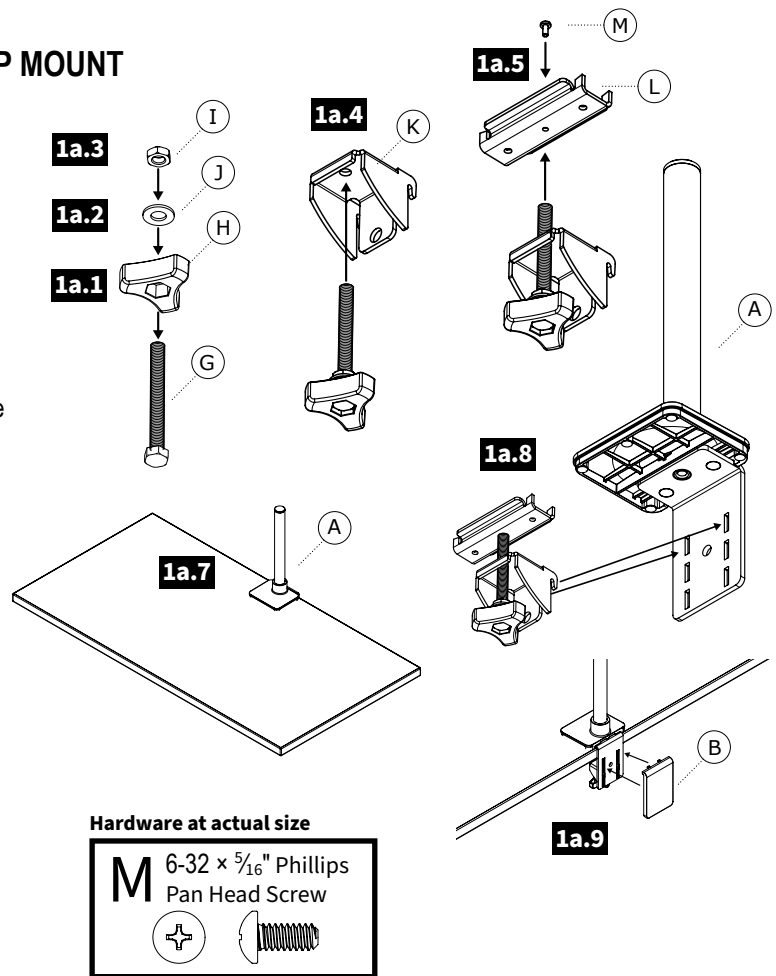

1b MOUNT BASE & POLE ASSEMBLY—GROMMET MOUNT

- 1b.1** Remove the L-Bracket from the 12" Pole Base (A) by removing the 2 screws from the base using a #3 Phillips screwdriver. Set the L-bracket aside
- 1b.2** Install the $\frac{3}{8}$ -16 \times 4.50"L Stud (O) into the base at least 8 full turns as shown
- 1b.3** Place the Pole Base & Stud into the grommet hole location for attaching to your desk

Note: If there is no grommet location in your desk you can drill a hole as small as $\frac{3}{8}$ " using a power drill and drill bit or you can use a hole saw and drill a larger hole up to 3" diameter to install the grommet mount option

- 1b.4** From the underside, place the Grommet Mount Channel (N) onto the Stud (O) with the "U" facing up as shown. Place the $\frac{3}{8}$ Washer (J) and the $\frac{3}{8}$ -16 Hex Nut (I) onto the Stud (O) and tighten securely

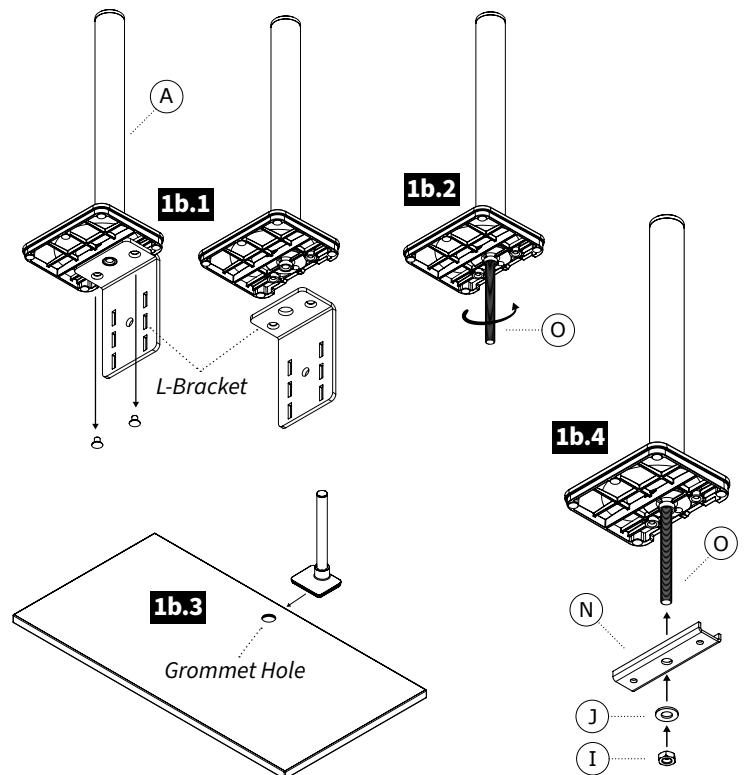

2 ATTACH TRIPLE ARM ONTO POLE

- 2.1 Place the first Support Ring (C) **smooth side facing up** onto the Pole (A), tighten the knob to lock in place
- 2.2 Slide the Triple Arm Assembly (D) onto the Pole (A) and Support Ring (C) as shown
- 2.3 Place the Trim Ring (F) onto the pole and into the Triple Arm Assembly (D)
- 2.4 Locate the two holes in the rear of the triple mount hub. Align the hub to the workstation then using the 1/8" Short Allen Wrench (V) tighten both set screws to lock the hub in place

Note: Height may need to be adjusted later after the monitor is installed

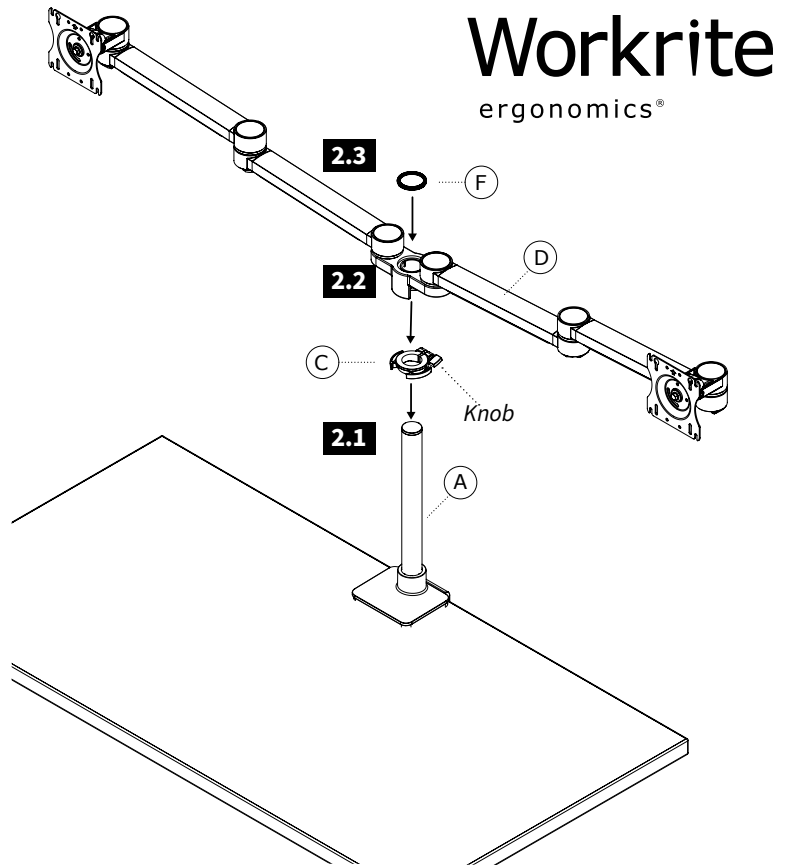
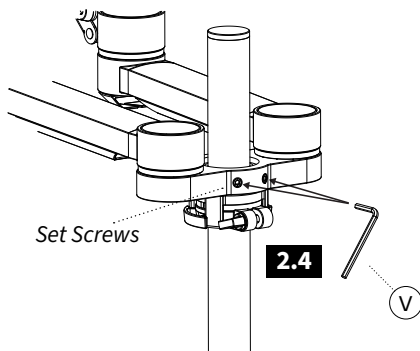

3 ATTACH SINGLE MONITOR MOUNT ONTO POLE

- 3.1 Place the second Support Ring/Cable Manager (C) **smooth side facing up** onto the Pole (A), tighten the knob to lock in place
- 3.2 Slide the Single Monitor Mount (E) onto the Pole (A) as shown
- 3.3 Place the Trim Ring (F) onto the pole and into the Single Monitor Mount (E)

Note: Height may need to be adjusted later after the monitor is installed

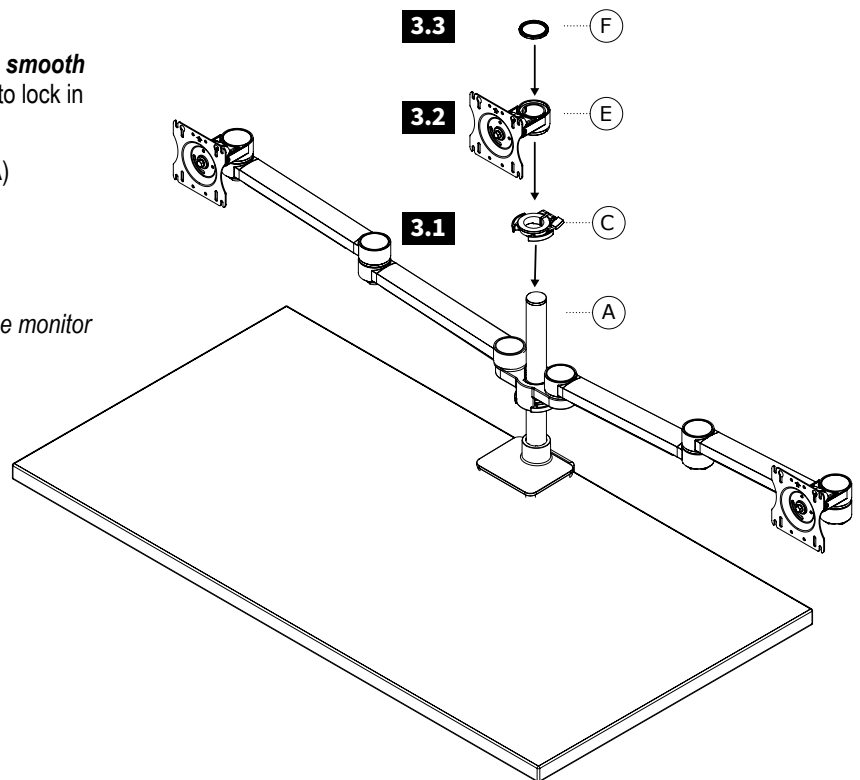

4 ATTACH THE QUICK RELEASE BRACKET & INSTALL THE MONITOR

Note: Using the Quick Release Mount is optional. Your monitor can be attached directly to the VESA plate of the monitor mount if desired

- 4.1** Locate the VESA Mount Pattern on the back of your monitor

Note: In some cases, the VESA mounting pattern is hidden by a removable cover or the monitor base. These must be removed to install the Quick Release or mount the monitor

- 4.2** Mount the Quick Release (P) to the VESA mount on your monitor as shown with four (4) M4 Screws either (Q), (R), (S) or (T) and tighten securely

- 4.3** Repeat the above steps for the remaining 3 monitors

Note: Always use the shortest screws possible to avoid damaging the display by using screws that are too long

Note: In some case your monitor may require the use of the $\frac{3}{8}$ " Spacers (U) to allow proper installation of the Quick Release (P)

- 4.4** Aligning the Monitors with Quick Release onto the VESA Plate on the arms, sliding down to lock in place as shown

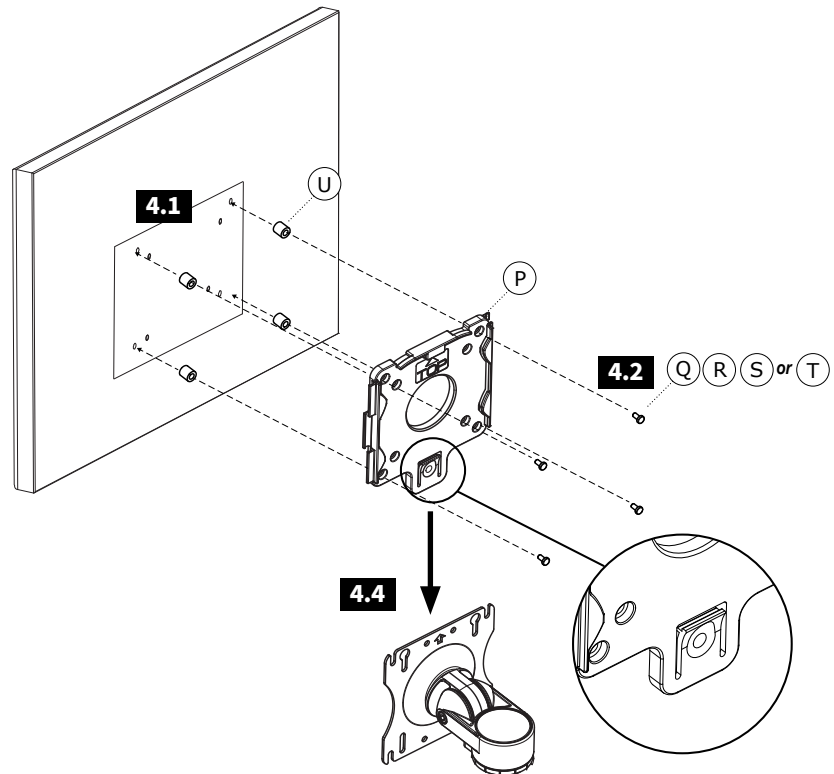

5 CABLE MANAGEMENT

- 5.1** Place monitor cables into the cable retainers of the Pole support ring

Note: Make sure there is slack in the cables that allows movement to tilt and rotate the monitor without binding

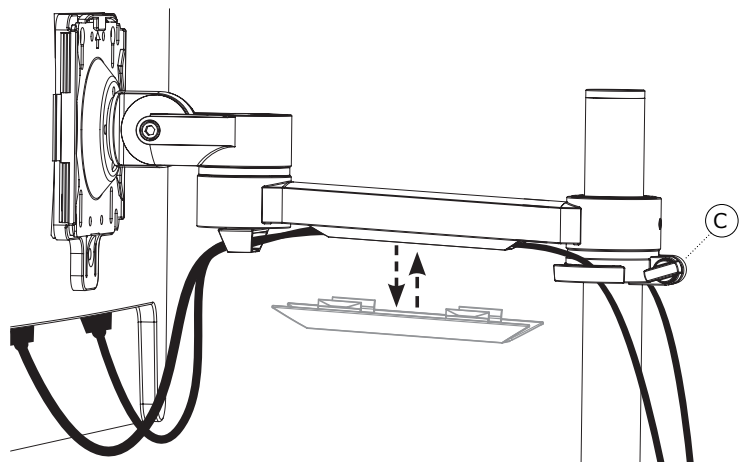

6 ADJUSTING TRIPLE MONITOR ARM HEIGHT

- 6.1 On the Triple Arm Assembly (D) loosen the set screws as shown with the $\frac{1}{8}$ " Short Allen Wrench (V)
- 6.2 Lift the Triple Arm (D) and monitors off the Support Ring (C)
- 6.3 Loosen the knob and raise or lower the Support Ring to the desired height and re-tighten
- 6.4 Lower the Triple Arm onto the Support Ring
- 6.5 Align the hub to the workstation then using the $\frac{1}{8}$ " Short Allen Wrench (V) tighten both set screws to lock the hub in place

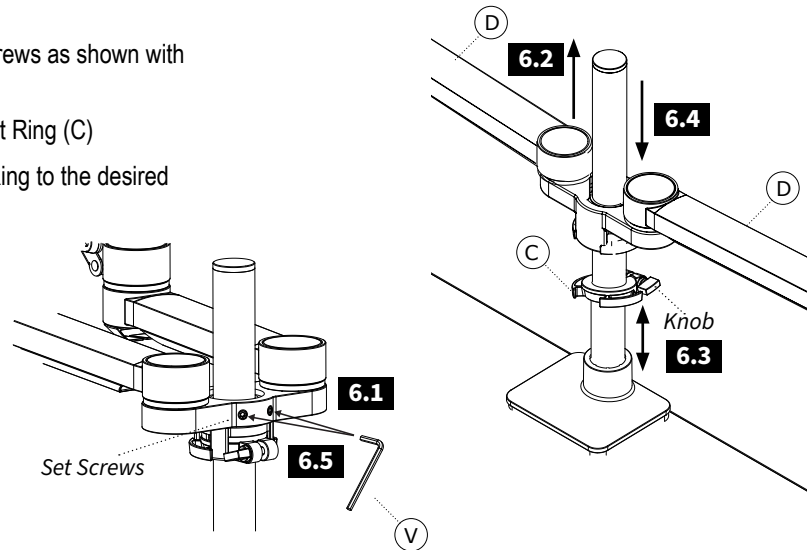

7 ADJUSTING SINGLE MONITOR MOUNT HEIGHT

- 7.1 Lift the Single Monitor Mount (E) and monitor off the Support Ring (C)
- 7.2 Loosen the knob and raise or lower the ring to the desired height and re-tighten
- 7.3 Lower the monitor mount and monitor back onto the support ring

Note: The order of adjustment for upper or lower arm height depends on which direction you are moving, Up or Down, and can be reversed as required. To make the height adjustment easier you may want to remove your monitors prior to adjustment

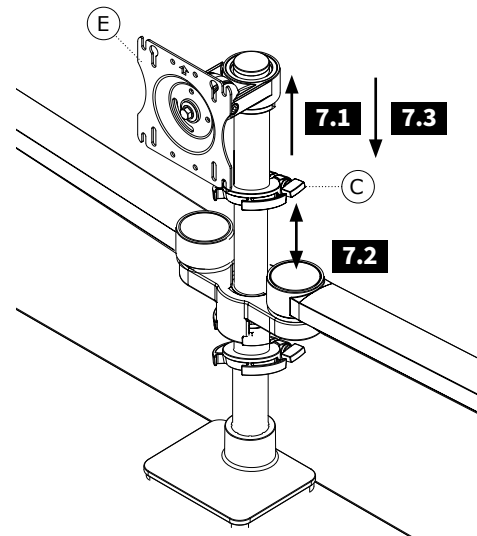

8 ADJUSTING MONITOR TILT

- 8.1 Locate the tilt adjustment bolt on the Monitor Mount(s)
- 8.2 If the monitor tilt is too difficult to tilt loosen the tilt adjustment bolt using the $\frac{3}{16}$ " Long Allen Wrench (W) until the monitor is easy to tilt but still holds in position after adjustments are made (do not over loosen)
- 8.3 If the monitor drops or is not holding tilt, tighten the tilt adjustment bolt using the $\frac{3}{16}$ " Long Allen Wrench (W) until the monitor holds tilt but still allows tilt adjustments to be made easily (do not over tighten)
- 8.4 Repeat as required to set the tilt for all mounted monitors

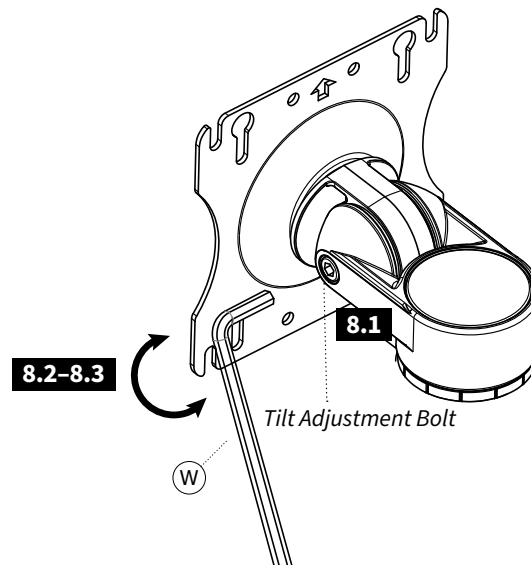

1500545 Rev A