

## Assembly & Installation Instructions:

### Conform Static 4 Display 2 over 2 Monitor Mount

CONF-ST422-30PB-TPCG-S

#### Parts Included

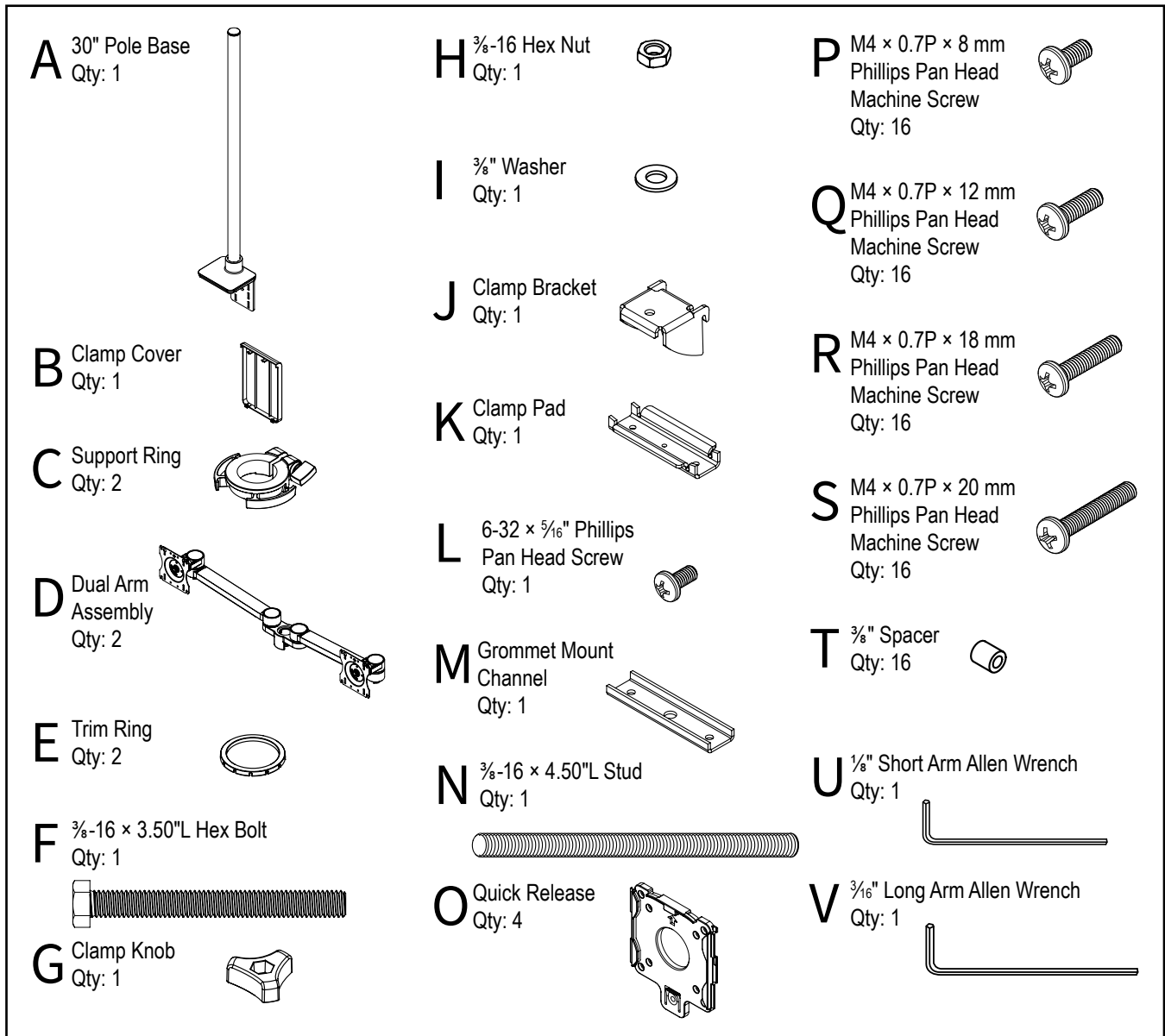

#### Tools Required:



Cordless Drill

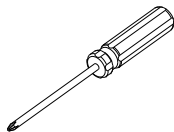

#3 Phillips Bit  
Screwdriver or  
Driver/Drill

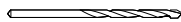

3/8" pilot drill bit

## 1a MOUNT BASE & POLE ASSEMBLY—CLAMP MOUNT

- 1a.1** Place the Clamp Knob (G) on the  $\frac{3}{8}$ -16  $\times$  3.50" L Hex Bolt (F)
- 1a.2** Place the  $\frac{3}{8}$  Washer (I) onto the Hex Bolt (F)
- 1a.3** Install the  $\frac{3}{8}$  Hex Nut (H) onto the Hex Bolt (F) and tighten to hold the knob in place
- 1a.4** Install the Bolt and Knob assembly into the Clamp Bracket (J)
- 1a.5** Attach the Clamp Pad (K) to the Hex Bolt as shown using the 6-32  $\times$   $\frac{5}{16}$ " Phillips Pan Head Screw (L)
- 1a.6** Set the Clamp Bracket Assembly aside
- 1a.7** Place the 30" Pole Base Assembly (A) on the rear edge of your worksurface
- 1a.8** From the underside, place the clamp bracket and knob assembly into the slots of the 12" Pole Base (A). Be sure the bracket is fully seated and tighten securely
- 1a.9** Install the Clamp Cover (B) as shown

*Note: Place the Clamp Bracket Assembly up as high as possible into the Pole Base to make it easy to tighten*

*Note: If your desk is against a wall or panel system where the bracket is not visible the Clamp Cover (B) is not needed and you can skip installing it*

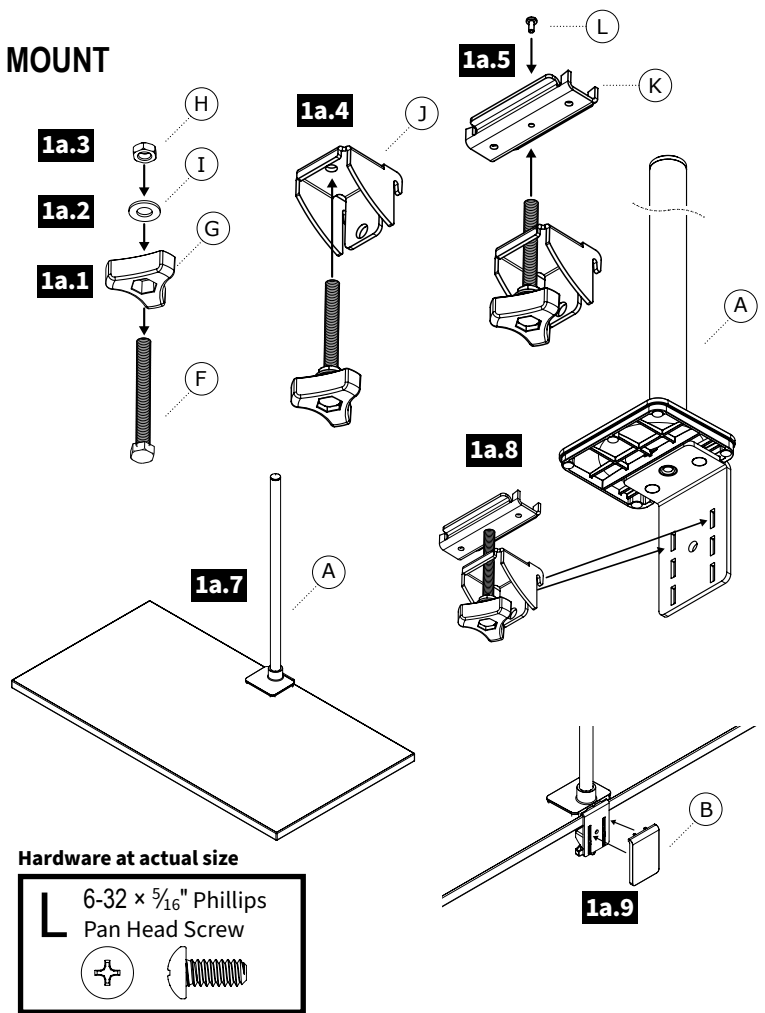

## 1b MOUNT BASE & POLE ASSEMBLY—GROMMET MOUNT

- 1b.1** Remove the L-Bracket from the 30" Pole Base (A) by removing the 2 screws from the base using a #3 Phillips screwdriver. Set the L-bracket aside
- 1b.2** Install the  $\frac{3}{8}$ -16  $\times$  4.50" L Stud (N) into the base at least 8 full turns as shown
- 1b.3** Place the Pole Base & Stud into the grommet hole location for attaching to your desk
- 1b.4** From the underside, place the Grommet Mount Channel (M) onto the Stud (N) with the "U" facing up as shown. Place the  $\frac{3}{8}$  Washer (I) and the  $\frac{3}{8}$ -16 Hex Nut (H) onto the Stud (N) and tighten securely

*Note: If there is no grommet location in your desk you can drill a hole as small as  $\frac{3}{8}$ " using a power drill and drill bit or you can use a hole saw and drill a larger hole up to 3" diameter to install the grommet mount option*

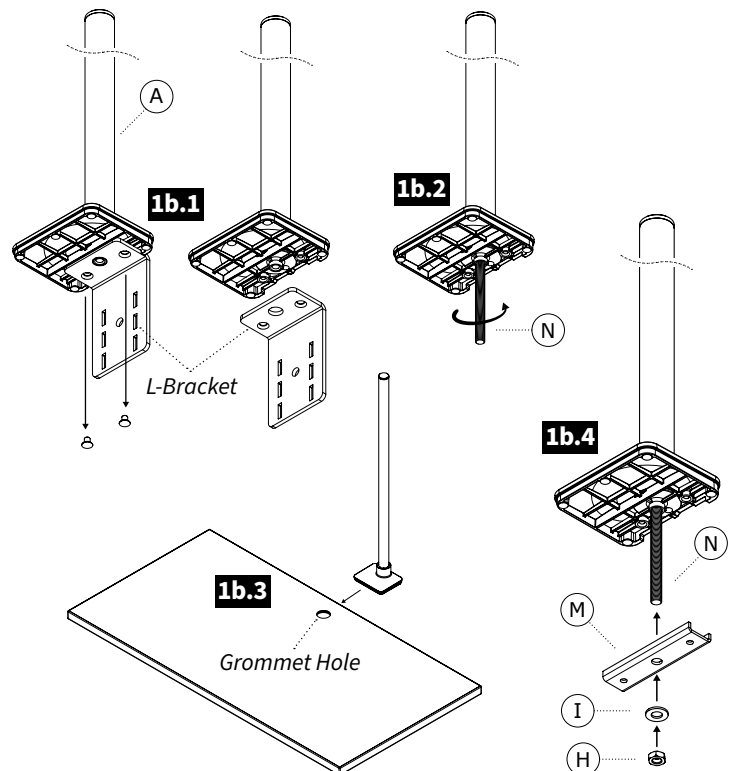

## 2 ATTACH DUAL ARMS ONTO POLE

- 2.1 Place the first Support Ring (C) **smooth side facing up** onto the Pole (A), tighten the knob to lock in place
- 2.2 Slide the Dual Arm Assembly (D) onto the Pole (A) and Support Ring (C) as shown
- 2.3 Place the Trim Ring (E) onto the pole and into the Double Arm Assembly (D)
- 2.4 Locate the two holes in the rear of the dual mount hub. Align the hub to the workstation then using the 1/8" Short Allen Wrench (U) tighten both set screws to lock the hub in place
- 2.5 Repeat the steps above for the second/upper Dual Arm Assembly

**Note:** Arm heights may need to be adjusted later as you install the monitor

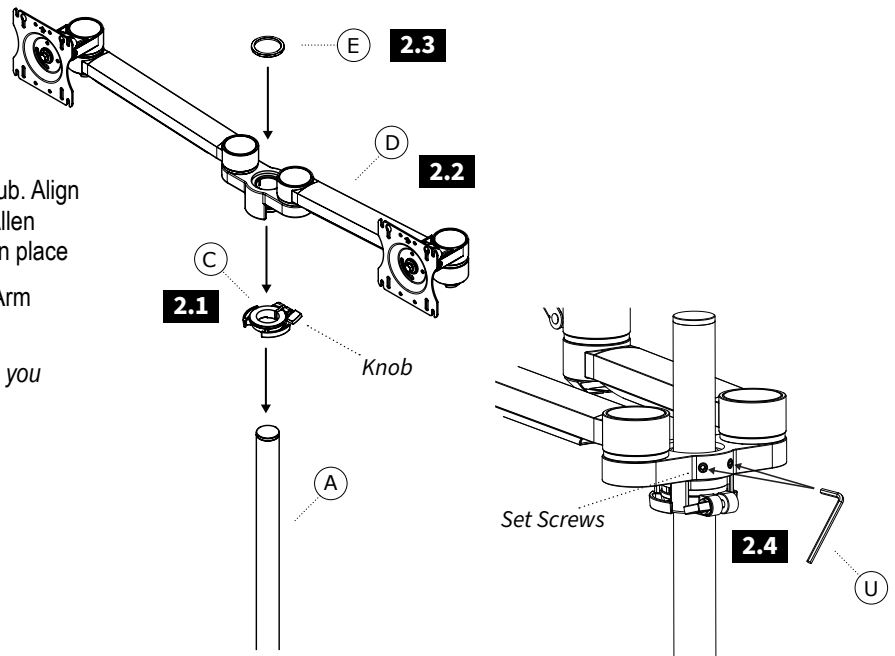

## 3 ATTACH THE QUICK RELEASE BRACKET & INSTALL THE MONITOR

**Note:** Using the Quick Release Mount is optional. Your monitor can be attached directly to the VESA plate of the monitor mount if desired

- 3.1 Locate the VESA Mount Pattern on the back of your monitor
- 3.2 Mount the Quick Release (O) to the VESA mount on your monitor as shown with four (4) M4 Screws either (P), (Q), (R) or (S) and tighten securely
- 3.3 Repeat the above steps for the remaining 3 monitors
- 3.4 Aligning the Monitor with Quick Release onto the VESA Plate and then sliding down to lock in place as shown

**Note:** In some cases, the VESA mounting pattern is hidden by a removable cover or the monitor base. These must be removed to install the Quick Release or mount the monitor

**Note:** Always use the shortest screws possible to avoid damaging the display by using screws that are too long

**Note:** In some case your monitor may require the use of the 3/8" Spacers (T) to allow proper installation of the Quick Release (O)

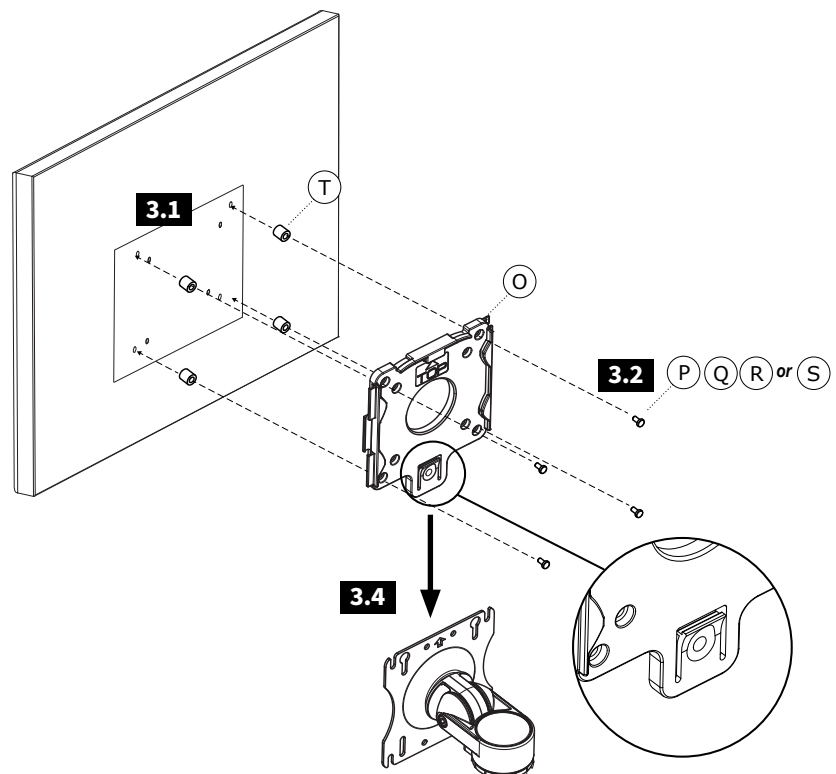

## 4 CABLE MANAGEMENT

- 4.1** Place monitor cables into the cable retainers of the Pole support ring

*Note: Make sure there is slack in the cables that allows movement to tilt and rotate the monitor without binding*

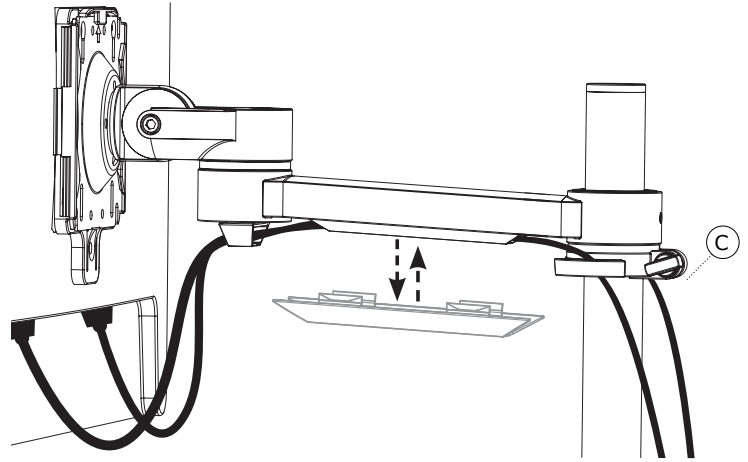

## 5 ADJUSTING MONITOR HEIGHT

- 5.1** On the Dual Arm Assembly (D) loosen the set screws as should with the  $\frac{1}{8}$ " Short Allen Wrench
- 5.2** Lift the lower level dual arm assembly and monitors off the Support Ring (C)
- 5.3** Loosen the knob and raise or lower the Support Ring to the desired height and re-tighten
- 5.4** Lower the monitor arm assembly and monitors back onto the support ring
- 5.5** Align the hub to the workstation then using the  $\frac{1}{8}$ " Short Allen Wrench (U) tighten both set screws to lock the hub in place
- 5.6** Repeated as required for the upper level monitor arm assembly

*Note: The order of adjustment for upper or lower arm height depends on which direction you are moving, Up or Down, and can be reversed as required. To make the height adjustment easier you may want to remove your monitors prior to adjustment*

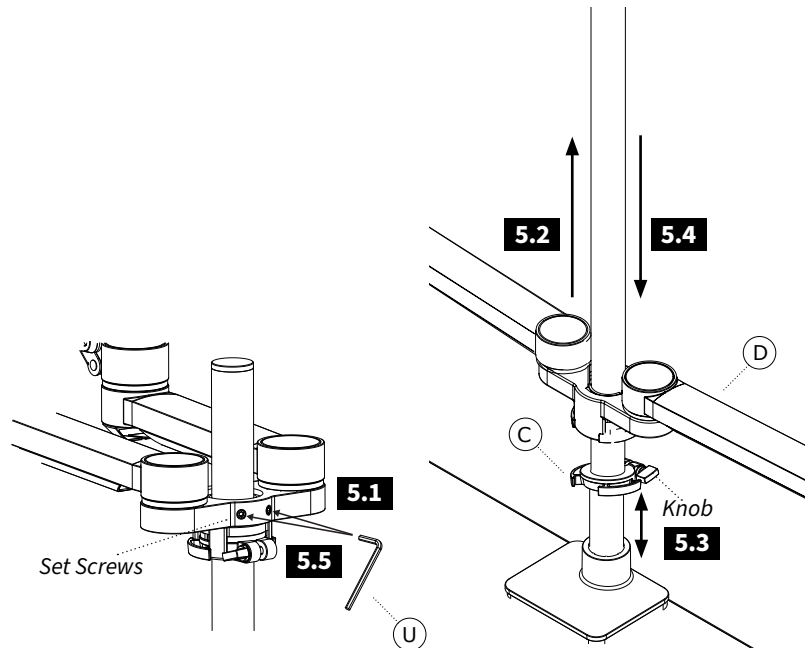

## 6 ADJUSTING MONITOR TILT

- 6.1** Locate the tilt adjustment bolt on the Monitor Mount(s)
- 6.2** If the monitor tilt is too difficult to tilt loosen the tilt adjustment bolt using the  $\frac{3}{16}$ " Long Allen Wrench (V) until the monitor is easy to tilt but still holds in position after adjustments are made (do not over loosen)
- 6.3** If the monitor drops or is not holding tilt, tighten the tilt adjustment bolt using the  $\frac{3}{16}$ " Long Allen Wrench (V) until the monitor holds tilt but still allows tilt adjustments to be made easily (do not over tighten)

