



DUAL EVO[®]

MONITOR ARMS



HAT
DESIGN WORKS™
HUMAN ACTIVE TECHNOLOGY

A SLEEK SPACE-SAVER.

Evo is ergonomics, space savings, and clever design all packed into one slim monitor arm. One-touch adjustment and an efficient cable management system keep things extra simple.



FEATURES

- **Balanced:** Tension adjustment at each joint allows for seamless counterbalance.
- **Responsive:** One-touch monitor adjustment.
- **Quick-Install:** Durable VESA plate(s) reduces installation time.
- **Flexible:** Easily rotate flat panel monitor for portrait or landscape viewing.
- **Compatible:** VESA-monitor compatible – 75mm & 100mm VESA adapter(s) included.

SPECIFICATIONS

Finishes

- Flat White
248
- Silver
124
- Vista Black
104

Dimensions

Screen Size: Up to 27"
Height Adjustment: 10.4"
Extension Range: 18"
Max Monitor Height: 19.6"
Weight Capacity: 1 - 15 lbs. per monitor
Mount: Desk Edge
(optional Grommet and Thru-Desk mount available)
Compatibility: Up to 1.5" desk thickness



Portrait/landscape viewing



Integrated cable management

Part Numbers

5902-__

WARRANTY

10 Years



CAPABILITIES

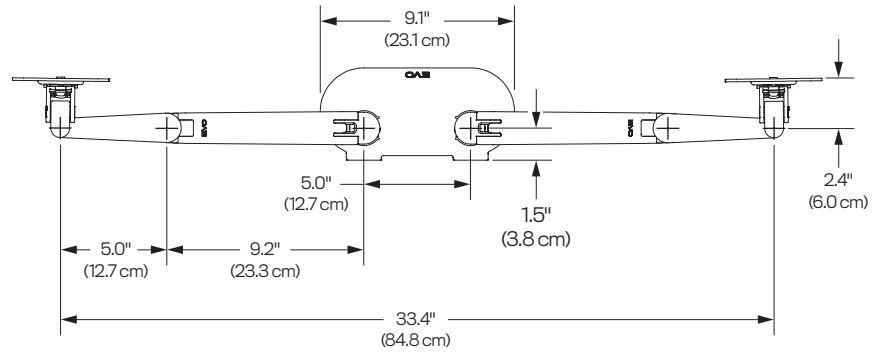
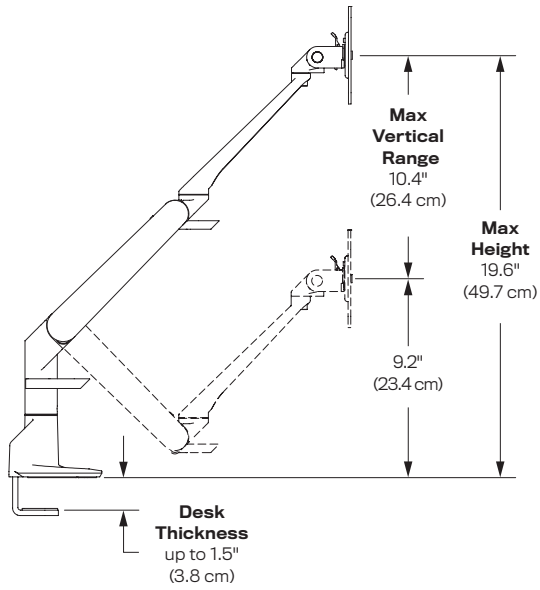

Desk Edge

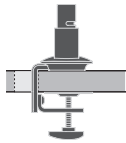

Grommet*
Model 8508

*Sold Separately

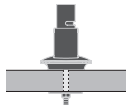

Thru-Desk*
Model 8508

*Sold Separately