

7500 DUAL

MONITOR ARMS



HAT
DESIGN WORKS™
HUMAN ACTIVE TECHNOLOGY

HEAVY DUTY FLEXIBILITY.

The 7500 Dual monitor arm allows for quick and easy monitor adjustment. This dual monitor mount features our convenient adjustable wing bracket, and a spring-assist tilter provides independent rotation and effortless monitor motion.



Integrated cable management



Flexible monitor positioning





Space-saving design

FEATURES

- **Effortless:** Instantly raise and lower your monitor with one handed repositioning.
- **Flexible:** Position monitors horizontally (side-by-side) or vertically (stacked one over the other).
- **Space:** Floats both monitors above the desk for a space-saving design.
- **Compatible:** VESA-monitor compatible – 75mm & 100mm quick-release VESA adapters included.

SPECIFICATIONS

Finishes

	Flat White 248
	Silver 124
	Vista Black 104

Dimensions

Screen Size: Up to 24"
 Height Adjustment: 18"
 Extension Range: 27"
 Max Monitor Height: 19"
 Weight Capacity: 1 – 18.7 lbs. per monitor
 Mount: Desk Edge, Thru-Desk,
 Grommet, Wall, Reverse Wall, Side Bolt

Part Numbers

7500-WING-1000-___ (1 – 11.4 lbs. per monitor)
 7500-WING-1500-___ (2.5 – 18.7 lbs. per monitor)

WARRANTY

10 Years



HAT
DESIGN WORKS™
 HUMAN ACTIVE TECHNOLOGY

800 524 2744 hatdw.com

CAPABILITIES

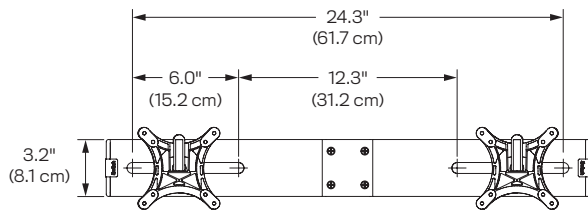
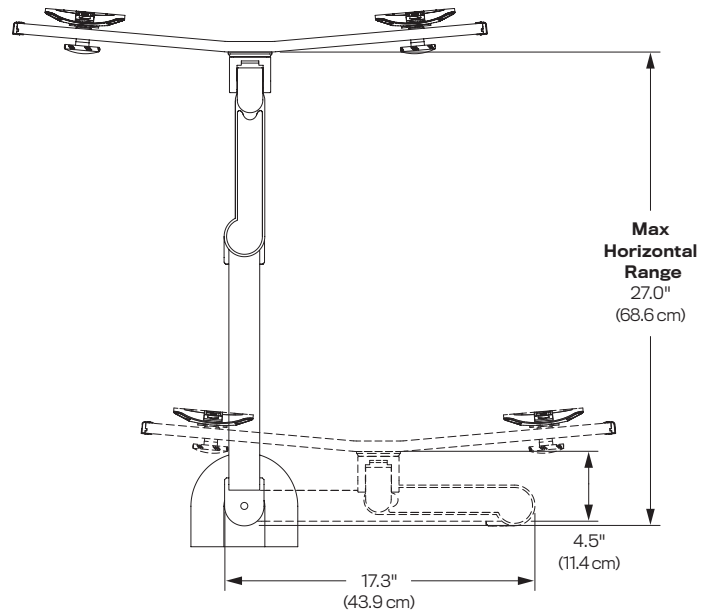
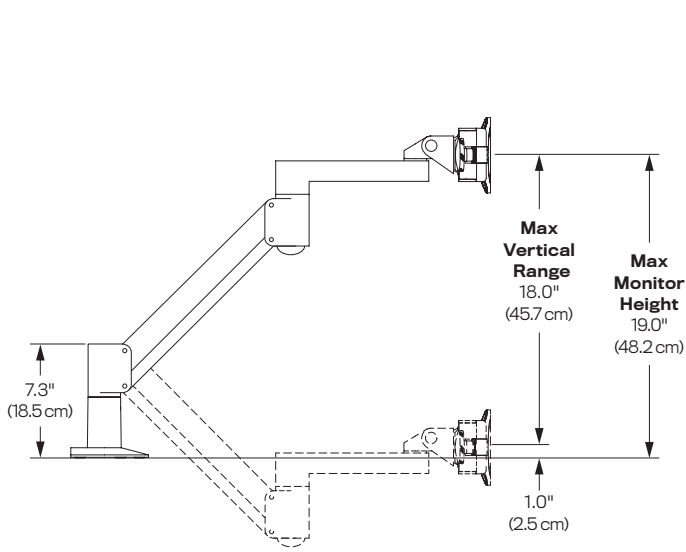

Desk Edge



Thru-Desk

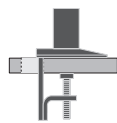

Grommet

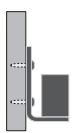

Wall



Reverse Wall



Side Bolt