

9110-8460 SERIES

MONITOR ARMS



HAT
DESIGN WORKS™
HUMAN ACTIVE TECHNOLOGY

SAVE MAXIMUM SPACE.

The 9110-8460 monitor mounting bracket is ideal for hanging monitors in IT server rooms, food service areas or industrial spaces that use wire shelving or racks. Secure the monitor to a 1" diameter wire shelf post using this mounting bracket. The 9110-8460 offers tilt, rotation and pivoting of monitor.



FEATURES

- **Adjustable:** This computer monitor and flat screen TV wall mount features adjustable tension at joints - ideal for touch-screen applications.
- **Easy:** Easily pivot the monitor from portrait to landscape.
- **Customizable:** Extend the mount with available 4" and 8" extension arms; they can also be combined to increase the extension up to 18".
- **Compatible:** VESA-monitor compatible - 75mm & 100mm VESA adapter included.

SPECIFICATIONS

Finishes

 Vista Black
104

Dimensions

Screen Size: Up to 43"

Extension Range:

4" (9110-8460)

7.6" (9110-8460-4)

11.1" (9110-8460-8.5)

14.6" (9110-8460-8.5-4)

18.1" (9110-8460-8.5-8.5)

Weight Capacity:

Up to 45 lbs. (9110-8460)

Up to 38 lbs. (9110-8460-4)

Up to 28 lbs. (9110-8460-8.5)

Up to 22 lbs. (9110-8460-8.5-4)

Up to 18 lbs. (9110-8460-8.5-8.5)

Part Numbers

9110-8460-___

9110-8460-4-___

9110-8460-8.5-___

9110-8460-8.5-4-___

9110-8460-8.5-8.5-___



9110-8460

9110-8460-4

9110-8460-8.5



9110-8460-8.5-4

9110-8460-8.5-8.5

WARRANTY

10 Years

CAPABILITIES

9110-8460

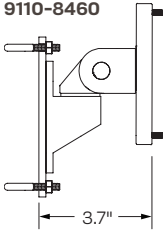

9110-8460-4

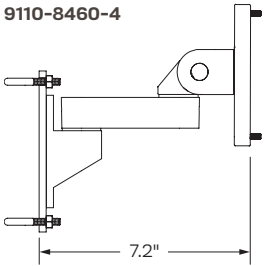

9110-8460-8.5

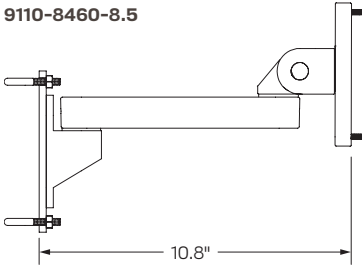

9110-8460-8.5-4

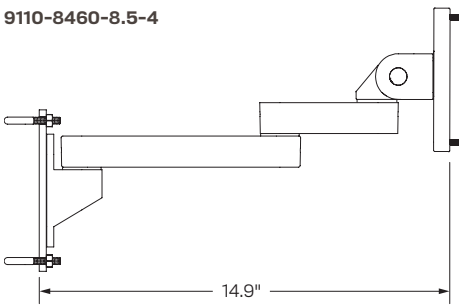

9110-8460-8.5-8.5

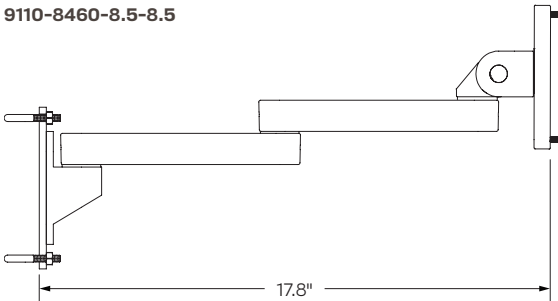

Mount
(All Models)

