

WINSTON E-DESK BEAM

Installation Instructions

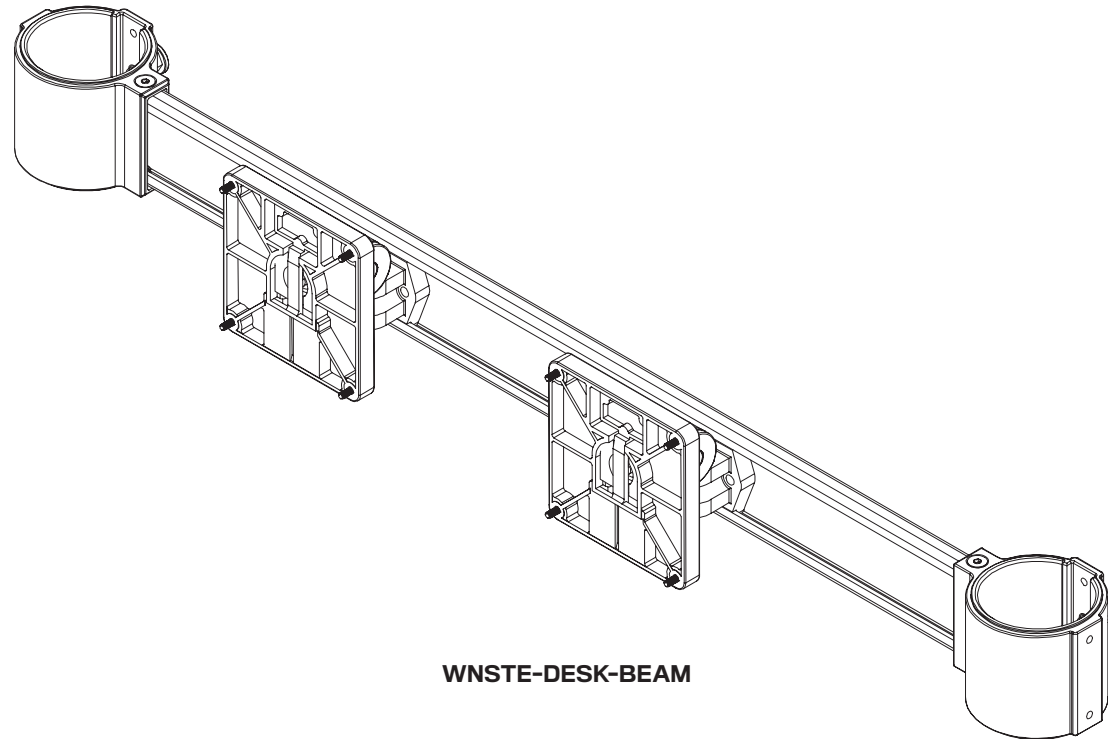

PARTS LIST

A Quick Connect VESA Plate 2x
114808

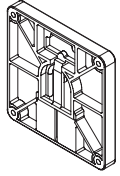

B M4 x 12mm Phillips Pan Head Screw 8x
701153

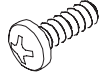

C Monitor Tilter 2x
8500 Tilter

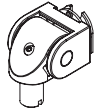

D Beam Assembly 1x
415302

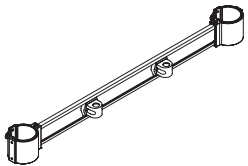

E M6 x 8mm 4x
715823



F M6 x 10mm 4x
715824



G Dog Washer 2x
111230-603



H 10-32 x 1/2" FHSCS 2x
711240



I 3mm Hex Key 1x
715650

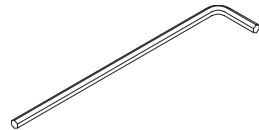

J 1/8" Allen Wrench 1x
701312



1

2x

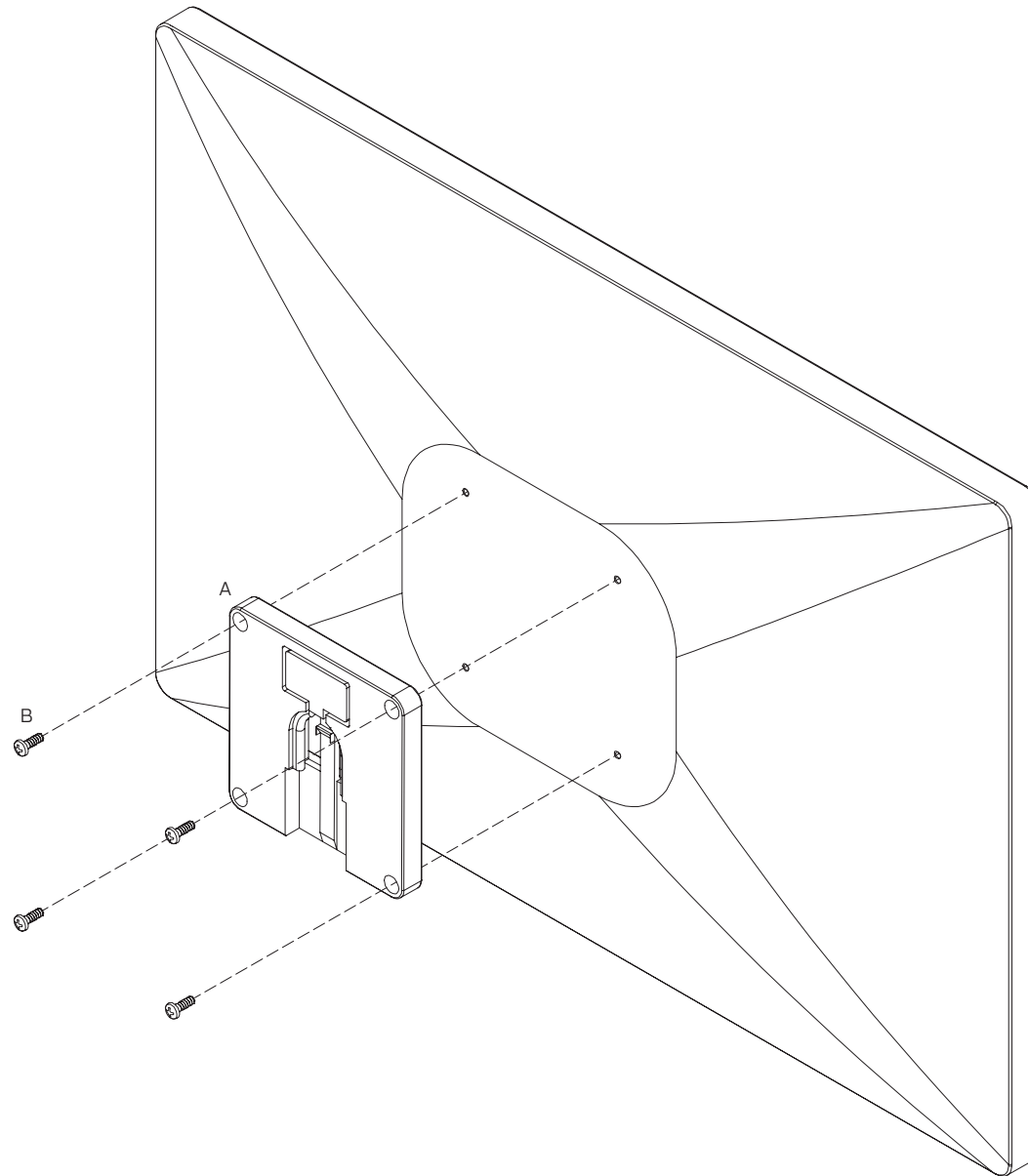
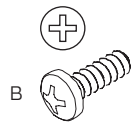

2x

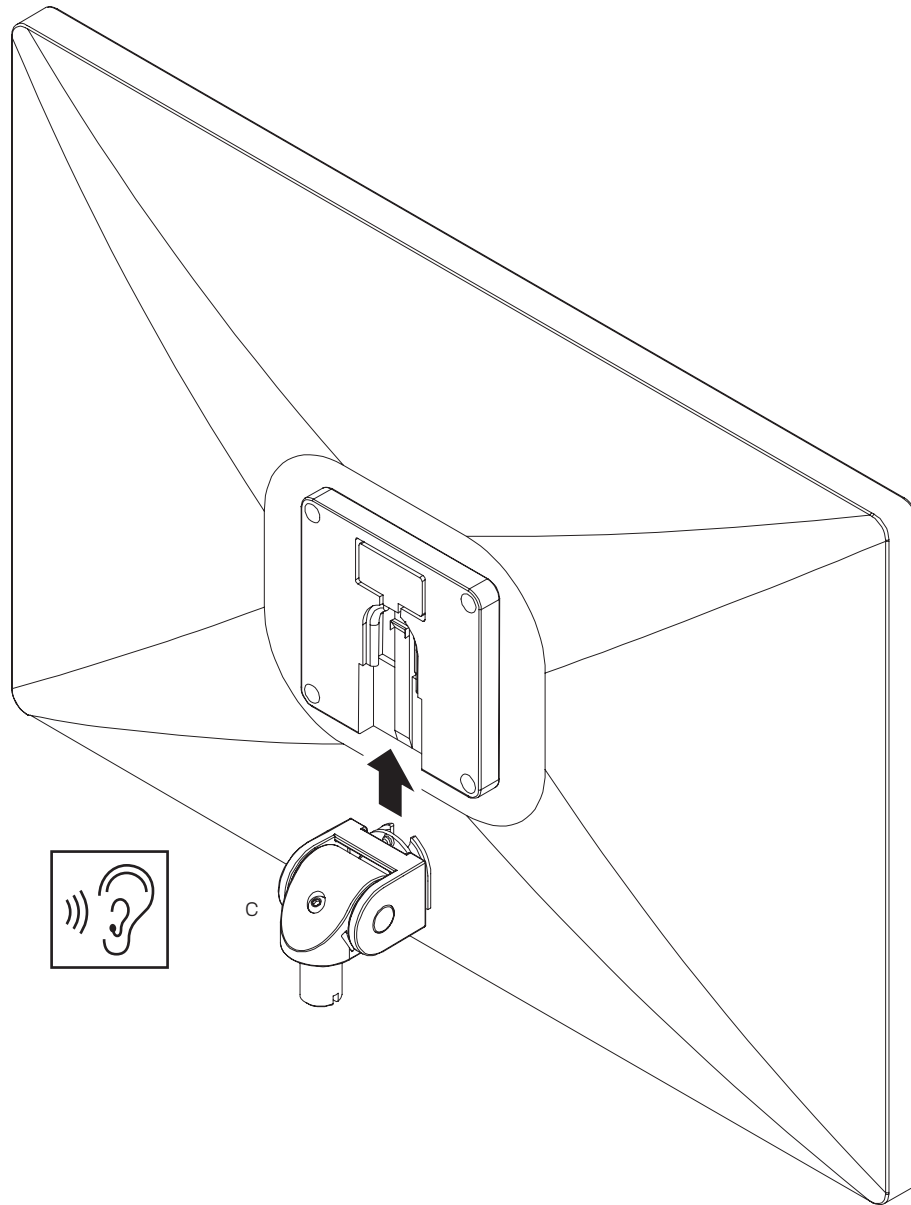

Beam is height adjustable, but monitors should be removed prior to adjustment.

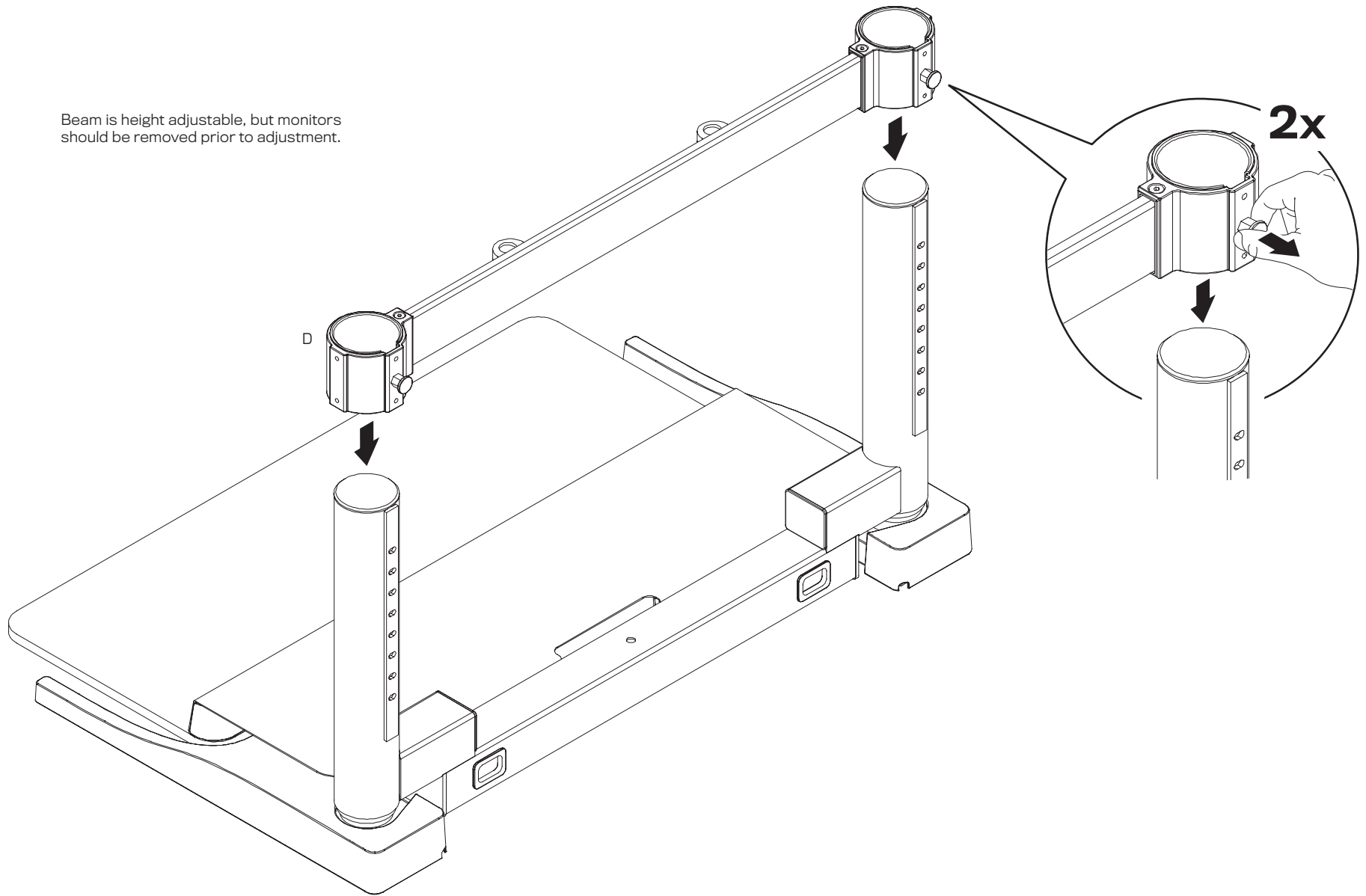

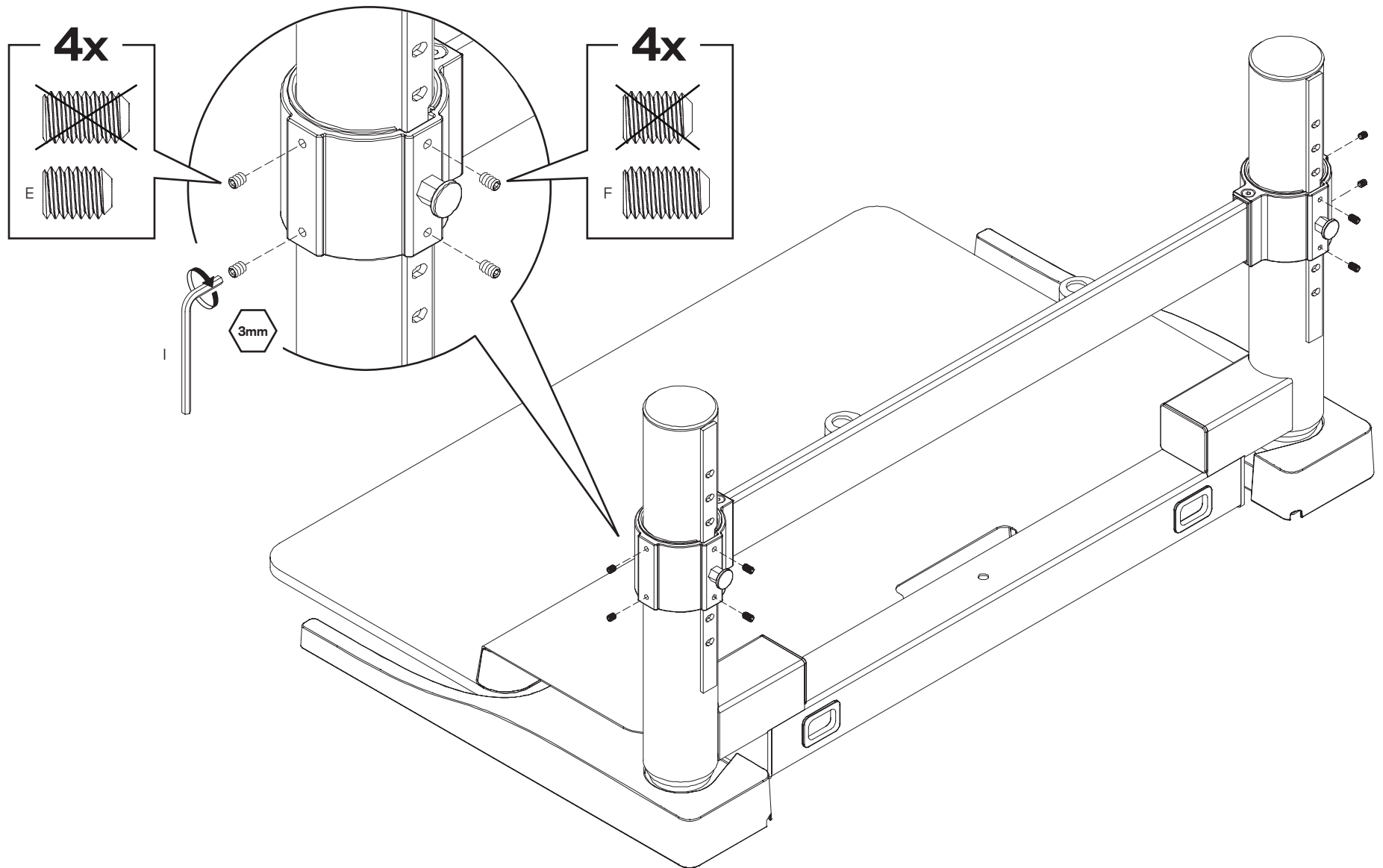

2x

