

ergotron®

StyleView Sit Stand Combo Arm Extender

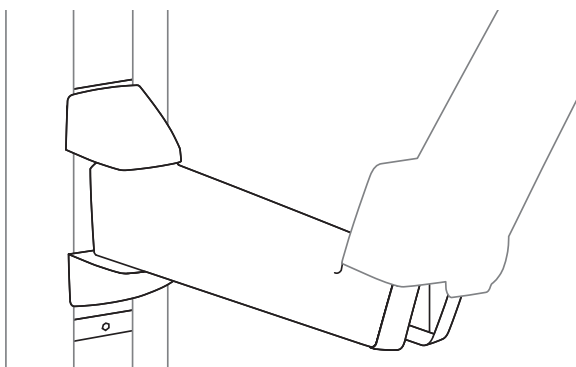

*Product shipped with rotation stop in place to prevent the Extender from hitting the wall.

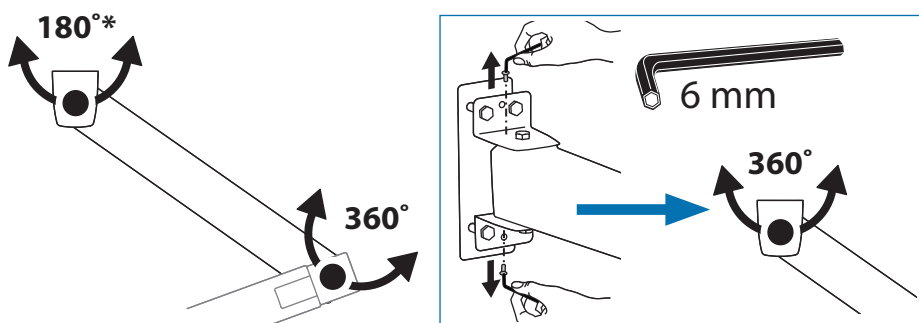

	A	B	C	D
1	1x 2x	1x 1x	1x	1x
2		1x	1x	1x
3		4x		1x
				1x

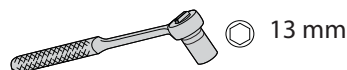
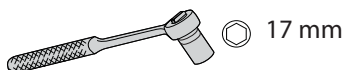
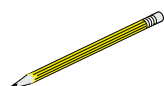
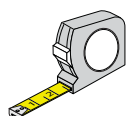

English



For the latest User Installation Guide please visit: www.ergotron.com

English, Español, Français, Deutsch, Nederlands, Italiano, Svenska, 日本語, 汉语

www.ergotron.com | USA: 1-800-888-8458 | Europe: +31 (0)33-45 45 600 | China: 400-120-3051 | Japan: japansupport@ergotron.com

1 Mounting Height for Ergonomic Workstation

This mounting height is a recommendation for an ergonomic workstation that accommodates user heights of 5'3"-5'9" (160-175cm). If user heights are different than this, you should change mounting height to accommodate user heights. (Change mounting height one inch for every one inch difference in user heights).

Combo Arm Extender

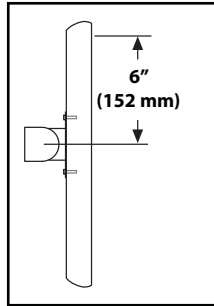
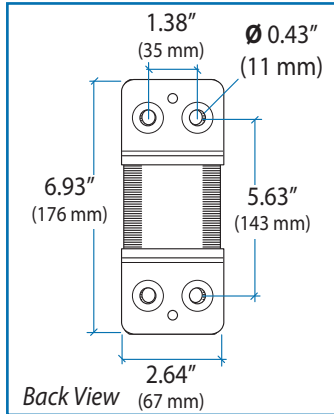

Mounting height assumes there is a 6" (152 mm) distance between the center of your monitor mounting holes and the top of the screen. If your distance is smaller, you should increase mounting height accordingly, if your distance is larger, you should decrease your mounting height accordingly.



NOTE: Fasteners may unwind due to vibration caused by movement of mounting solution over time. Inspect mounting solution for loose fasteners on a routine basis. If desired, apply a light duty thread locking adhesive to fasteners before installation to prevent back-out.

Combo Arm With Worksurface

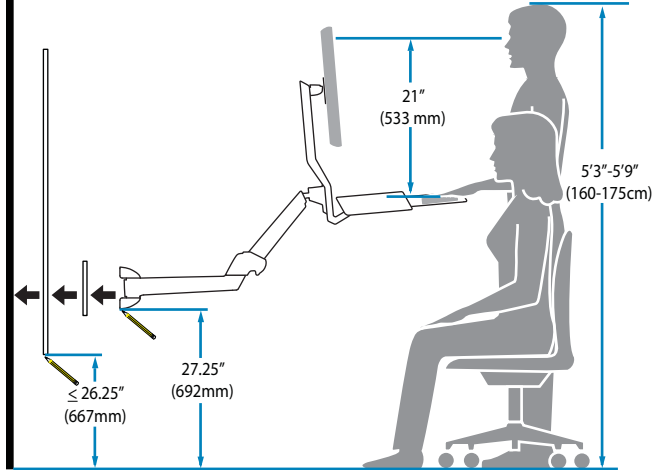

Determine mounting location:

Front view with arm pushed back against the wall.

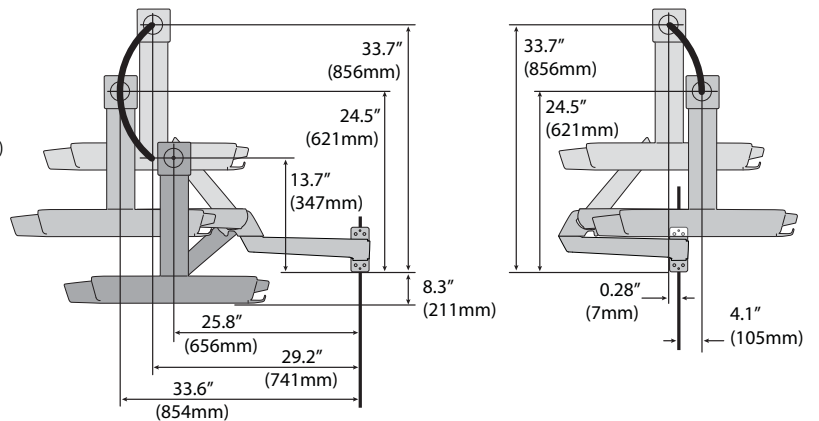

Combo Arm Without Worksurface

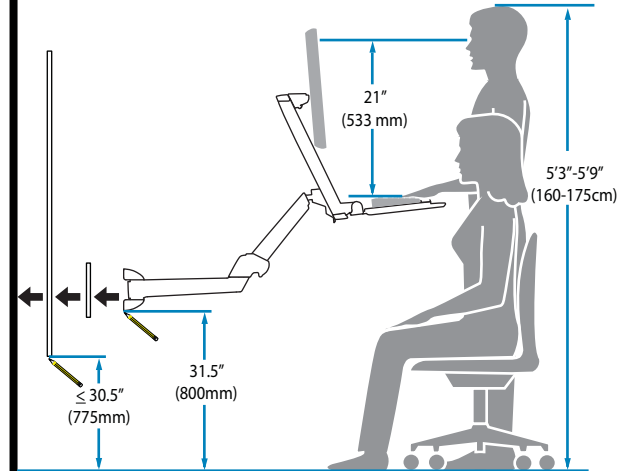

Determine mounting location:

Front view with arm pushed back against the wall.

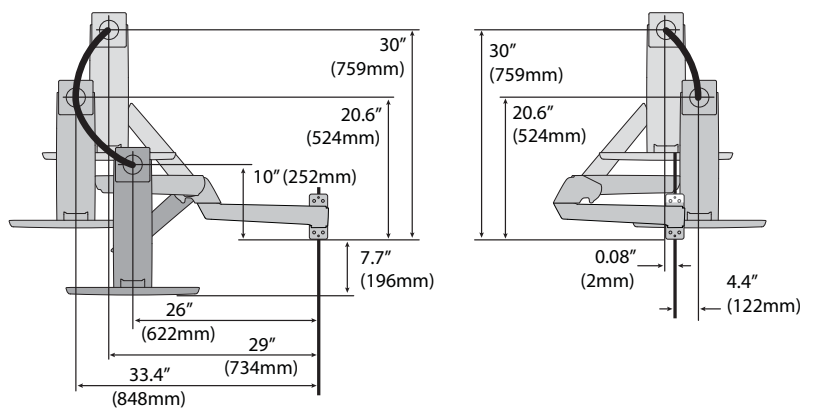

Top view showing range of motion when pulled out from the wall.

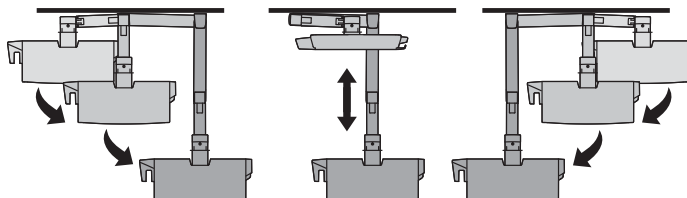

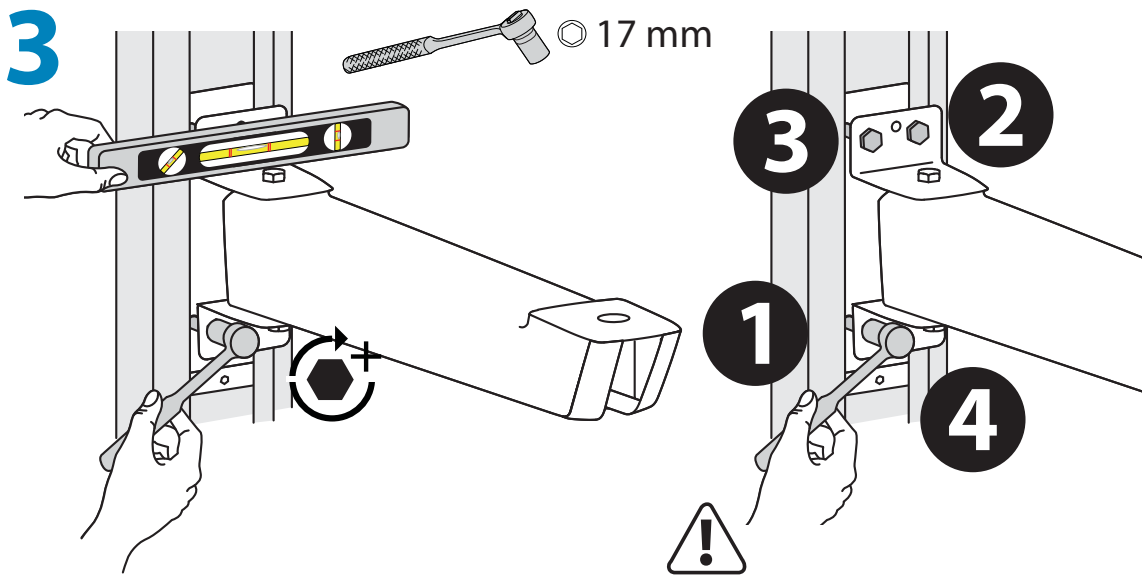
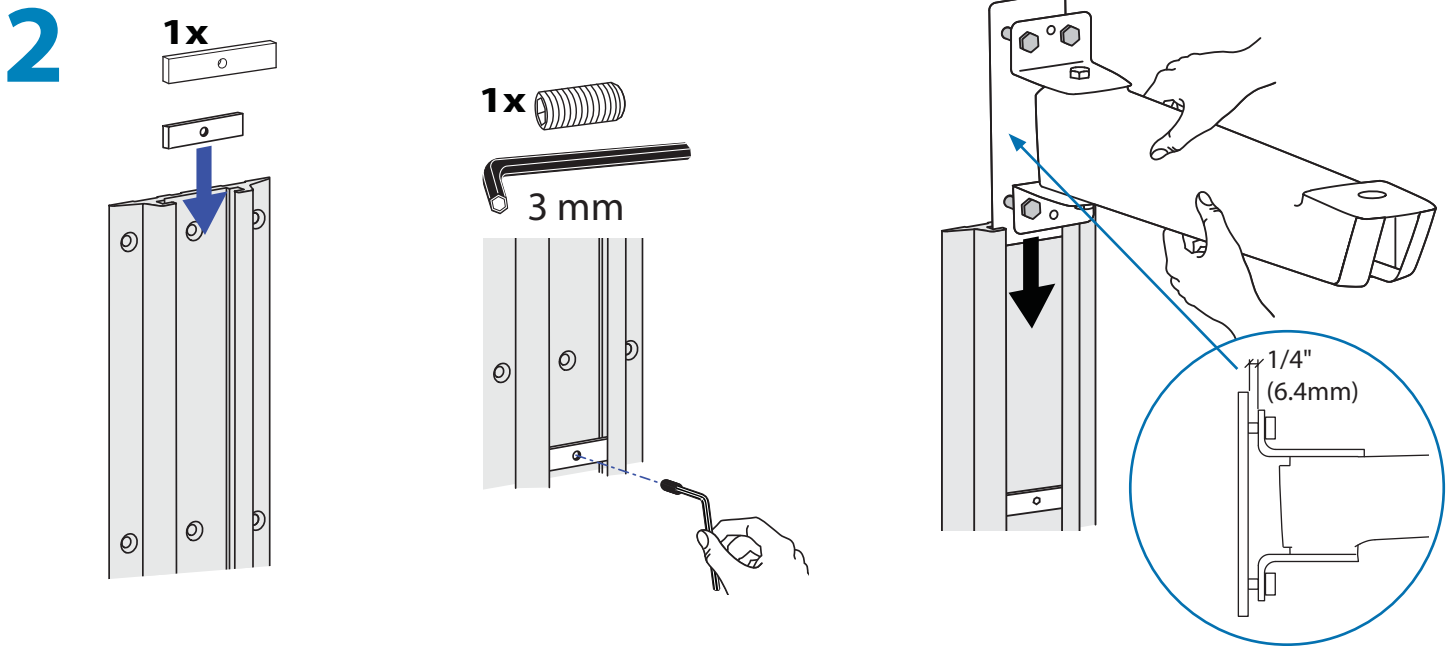

IMPORTANT! Torque bolts in the sequence shown above to a minimum of 50 lb-ft (6.91 kgf-m).

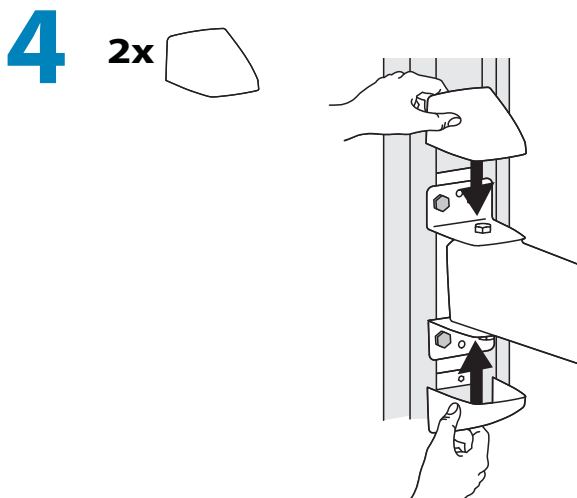

5

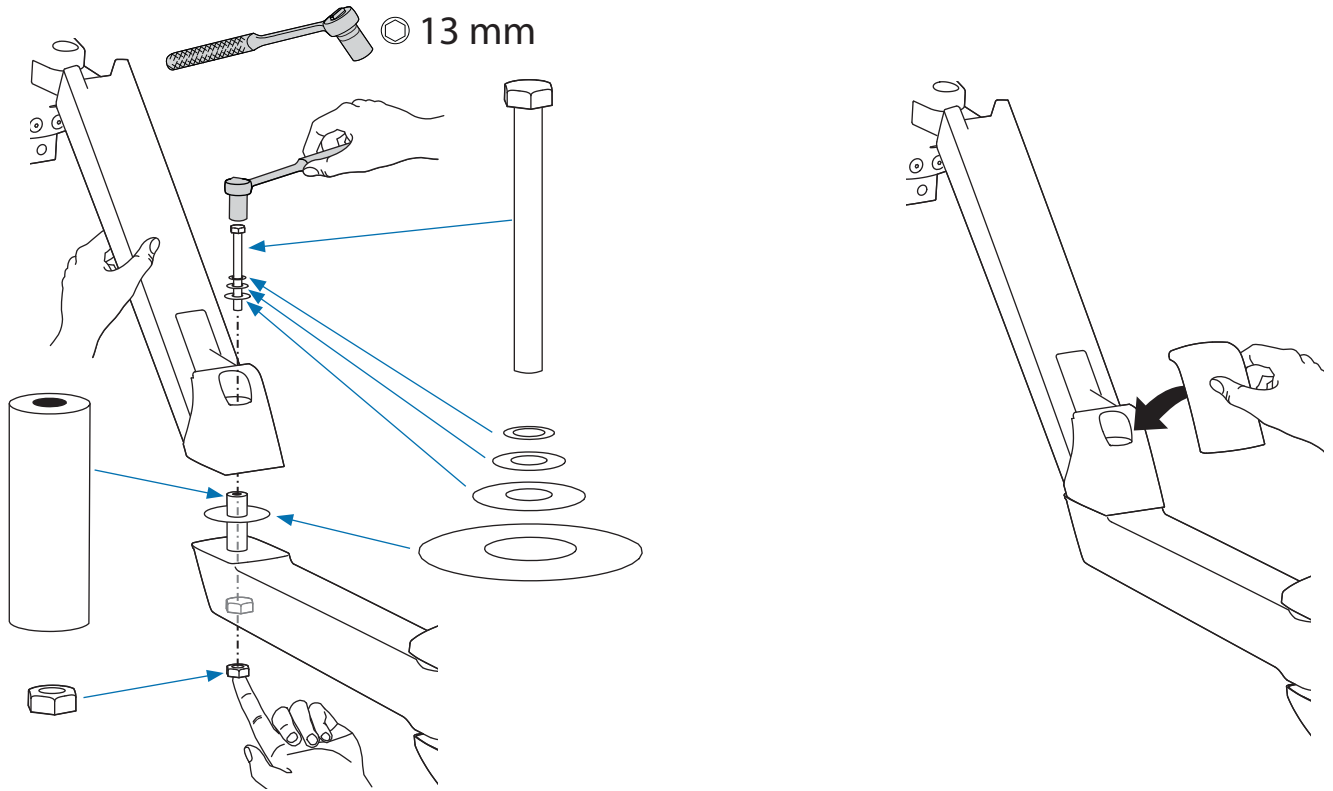

6

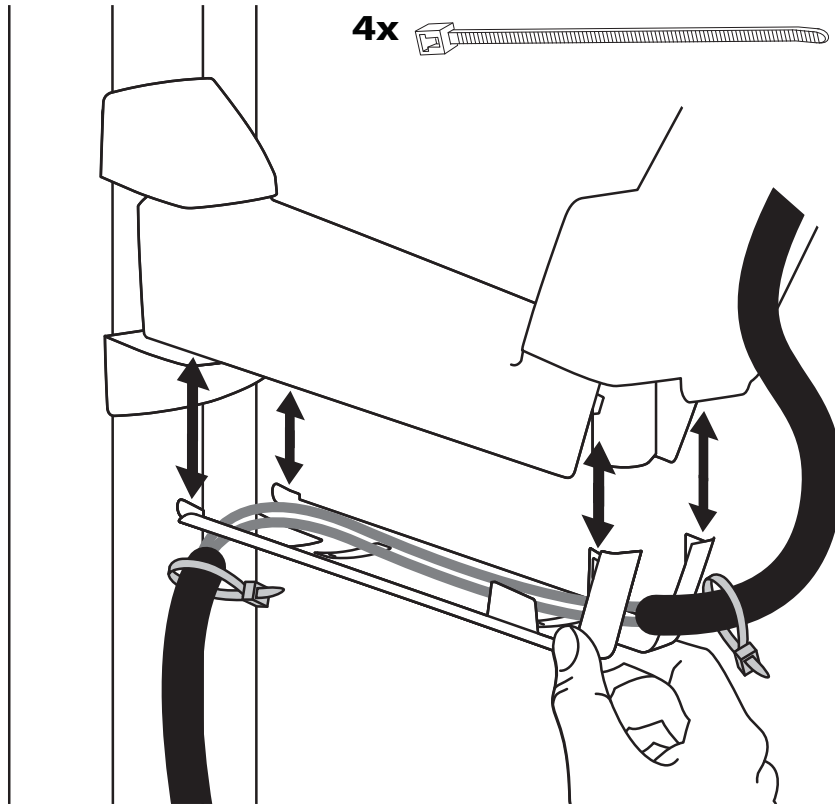

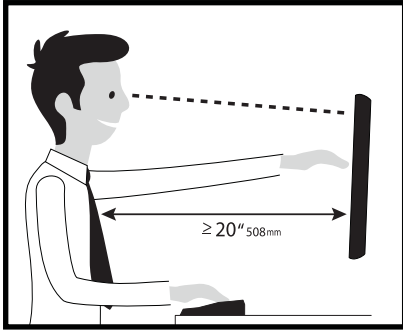

Learn more about ergonomic computer use at: www.ergotron.com/ergonomics

ergotron®

For Warranty visit: www.ergotron.com/warranty

For Service visit: www.ergotron.com

For local customer care phone numbers visit: <http://contact.ergotron.com>

www.ergotron.com | USA: 1-800-888-8458 | Europe: +31 (0)33-45 45 600 | China: 400-120-3051 | Japan: japansupport@ergotron.com

© 2013 Ergotron, Inc. All rights reserved.

While Ergotron, Inc. makes every effort to provide accurate and complete information on the installation and use of its products, it will not be held liable for any editorial errors or omissions (including those made in the process of translation from English to another language), or for incidental, special or consequential damages of any nature resulting from furnishing this instruction and performance of equipment in connection with this instruction. Ergotron, Inc. reserves the right to make changes in the product design and/or product documentation without notification to its users. For the most current product information, or to know if this document is available in languages other than those herein, please contact Ergotron. No part of this publication may be reproduced, stored in a retrieval system, or transmitted in any form or by any means, electronic, mechanical, photocopying, recording or otherwise without the prior written consent of Ergotron, Inc., 1181 Trapp Road, Eagan, Minnesota, 55121, USA. Patents Pending and Patented U.S. & Foreign. Ergotron is a registered trademark of Ergotron, Inc.