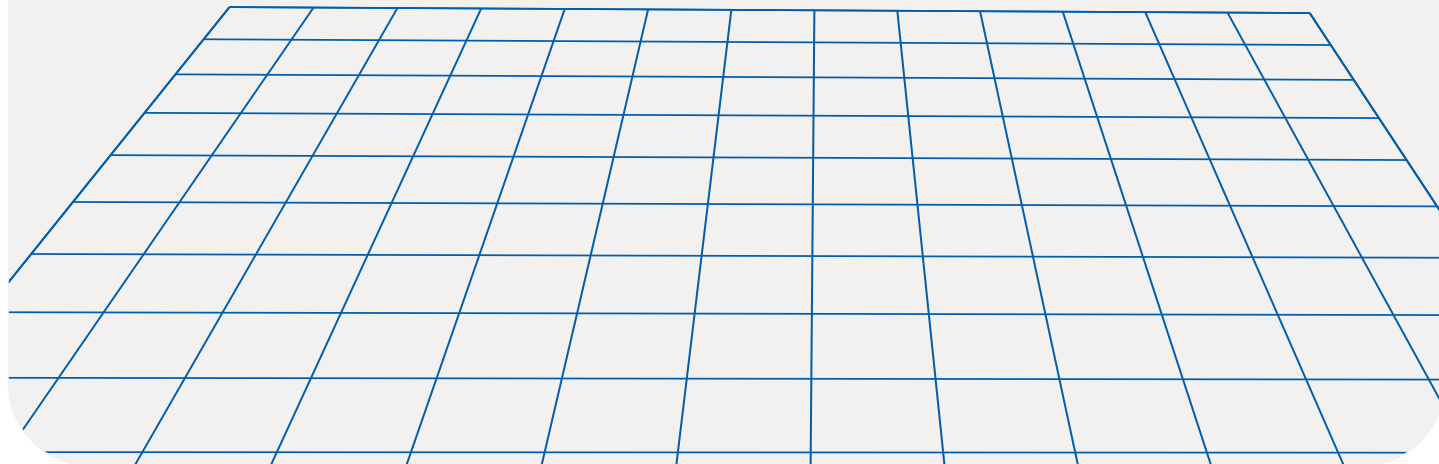


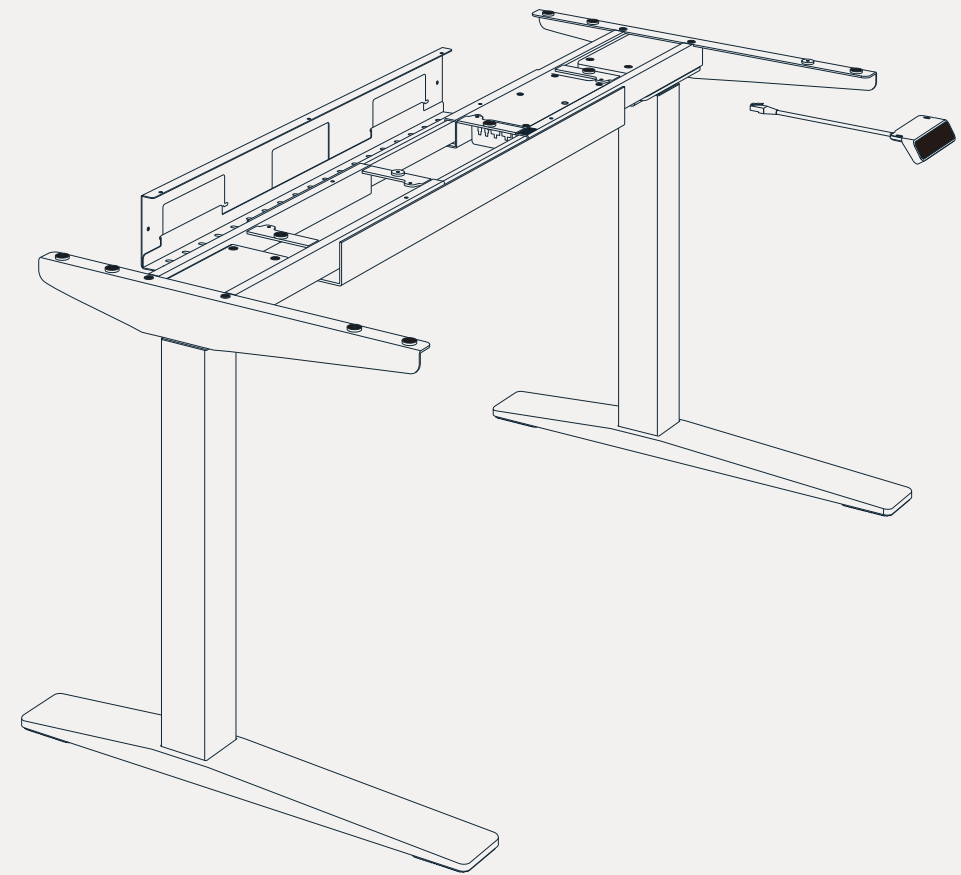
Work like new

Website: www.flexispot.com
Tel: 1-855-585-5618
Address: 6475 Las Positas Rd. Livermore, CA 94551



FlexiSpot

Item No. E7B-Pro/E7W-Pro/E7S-Pro
User Manual

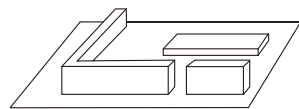




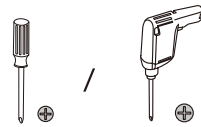
Specifications

Max. Static Load	440 lbs (200kg)
Max. Speed	1.5"/s
Adjustable Height	25"-50.6" (635-1285mm)
Adjustable Width	43.3"-74.8" (1100-1900mm)
Working Temperature	32°-104° F
Duty Cycle	10% (Working 2 minutes then stop 18 minutes)

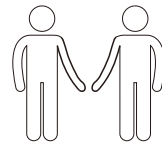
Pre-installation Guide



Assemble on a foam to prevent scratch



Phillips screwdriver or drill required (not provided)



Get a friend for help

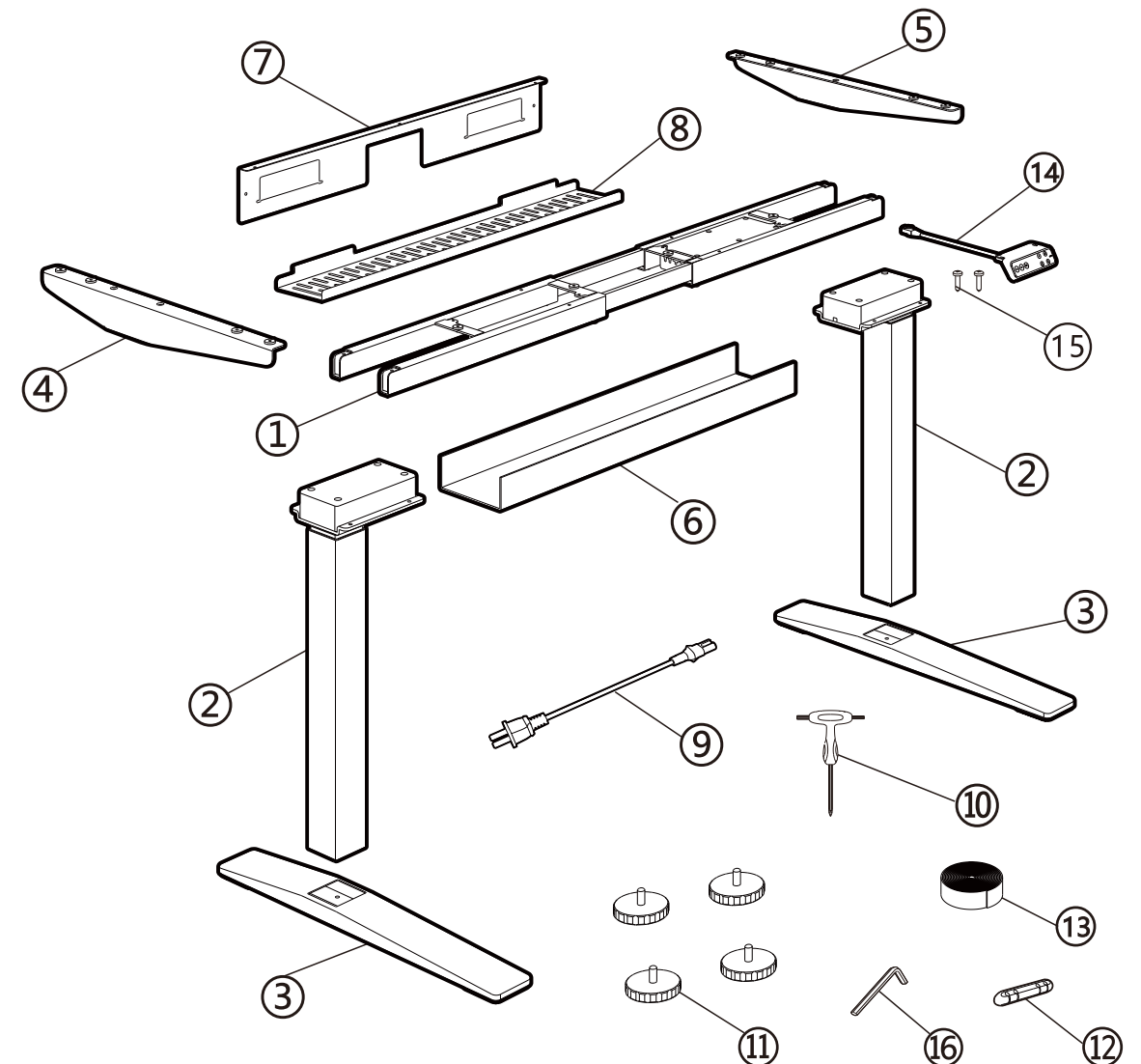
Accessory Package

Ax4	Bx4	Cx8	Dx8	Ex15

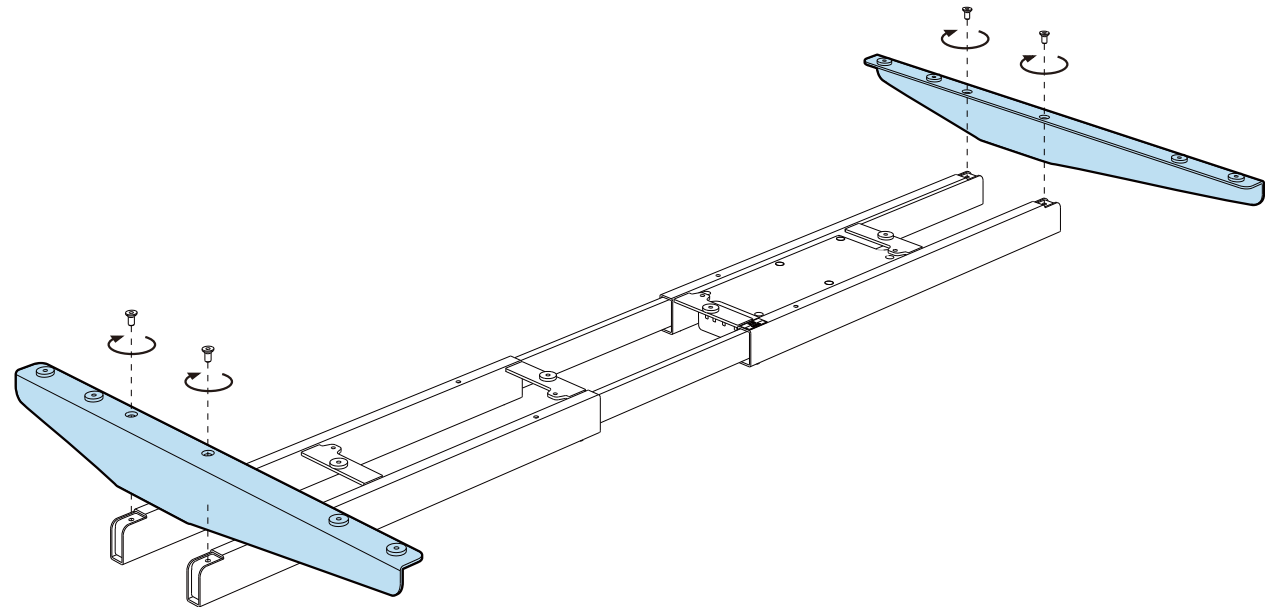
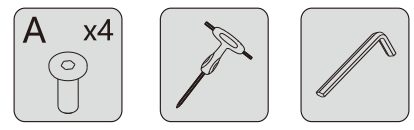


Diagram of Components

No.	Part	No.	Part
①	Supporting beam x1	⑨	Power plug x1
②	Lifting column x2	⑩	T-wrench x1
③	Feet x2	⑪	Feet pad x4
④	Left side bracket x1	⑫	Cable manager x1
⑤	Right side bracket x1	⑬	Velcro x1
⑥	Cable tray x1	⑭	Keypad x1
⑦	Cable holder x1	⑮	Keypad screw x2
⑧	Cable tray x1	⑯	4x4 wrench x1

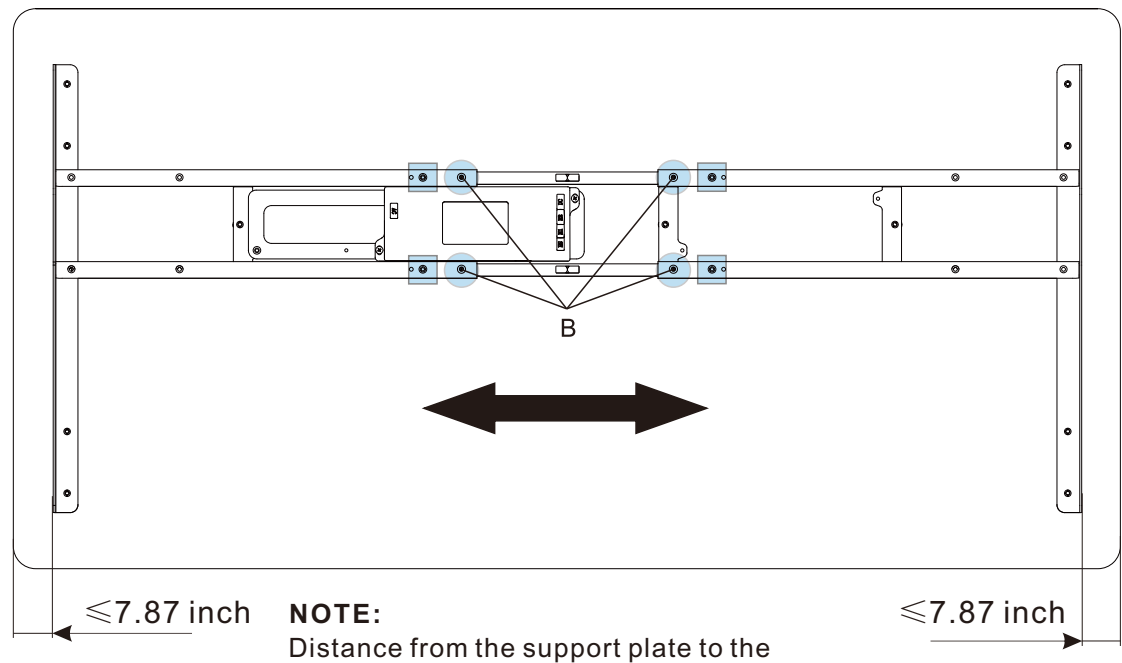
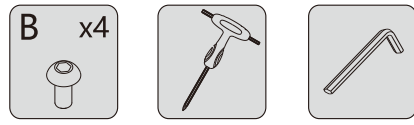


1 Attach the side brackets to the beam



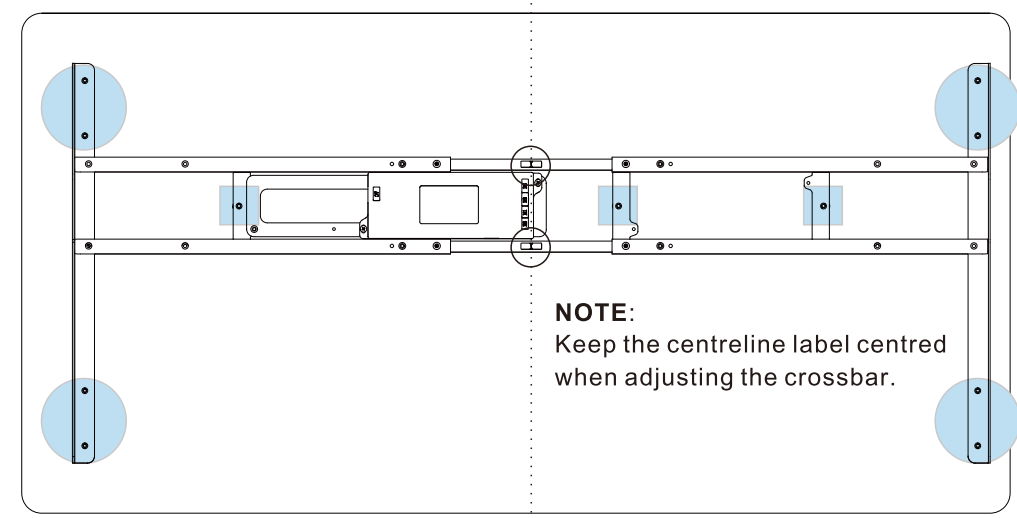
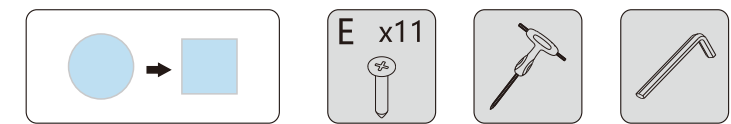
2 Adjust the length of the frame

a) Loosen the four screws shown ● and adjust the length of the crossbar
 b) After confirmation, tighten the eight screws shown by ● and ■



NOTE:
 Distance from the support plate to the edge of the table top not exceeding 7.87 inch.

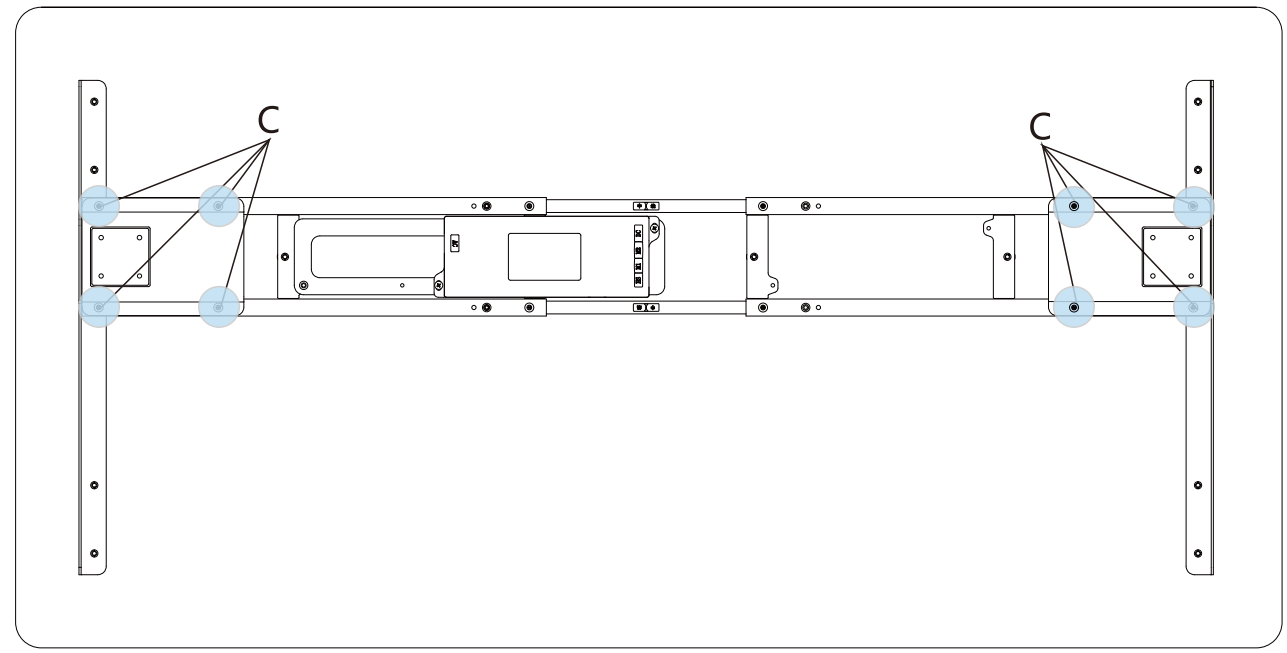
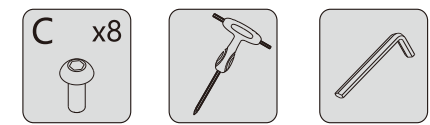
3 Affix the tabletop



NOTE:
 Keep the centreline label centred when adjusting the crossbar.

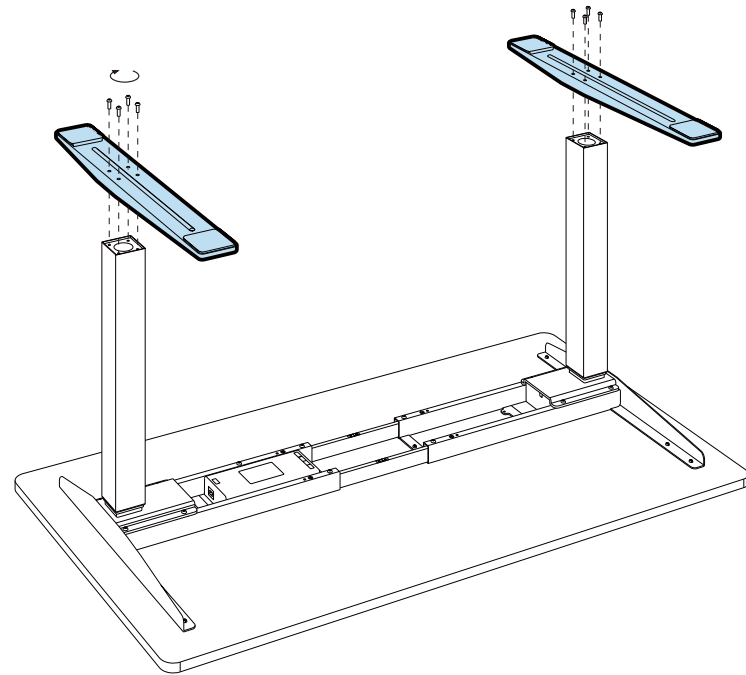
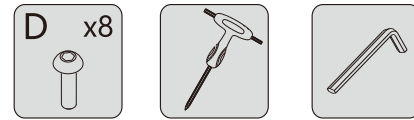
NOTE:
 When the beam is stretched to the widest point, 11 screws need to be installed to fix the table, and 1 spare screw. Otherwise, only 10 screws need to be installed to fix the table, and 2 spare screws.

4 Install the leg columns

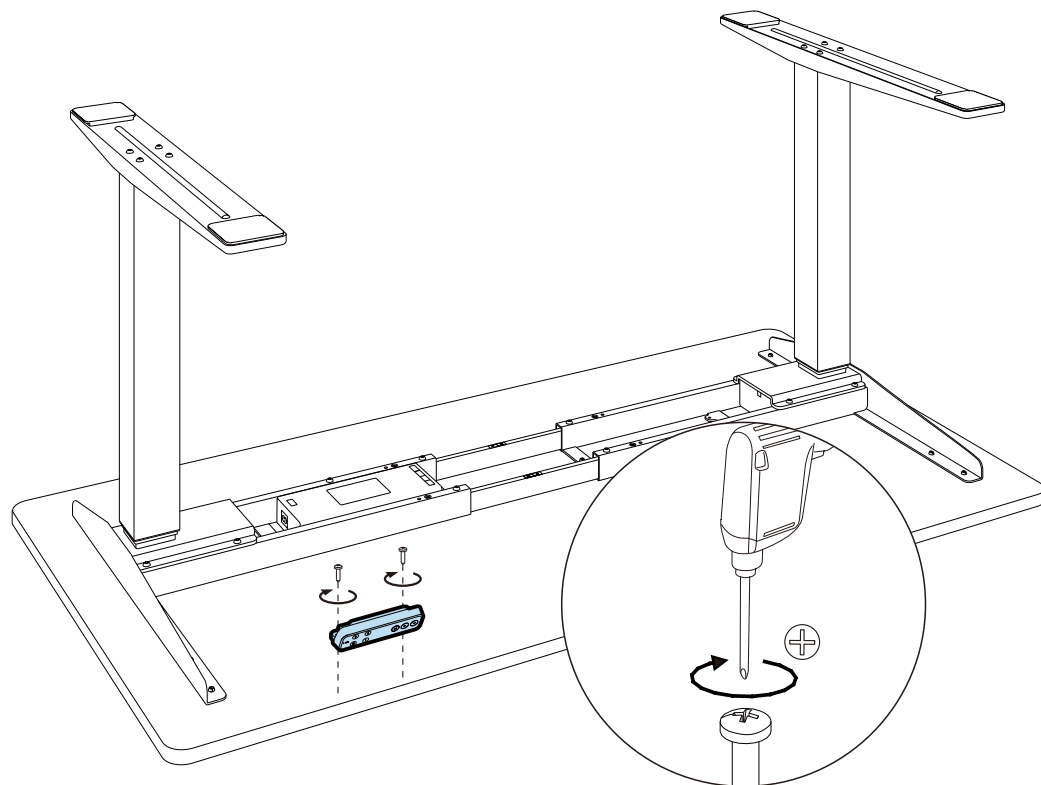
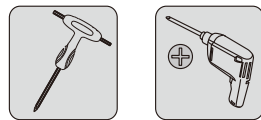


5 Attach the feet

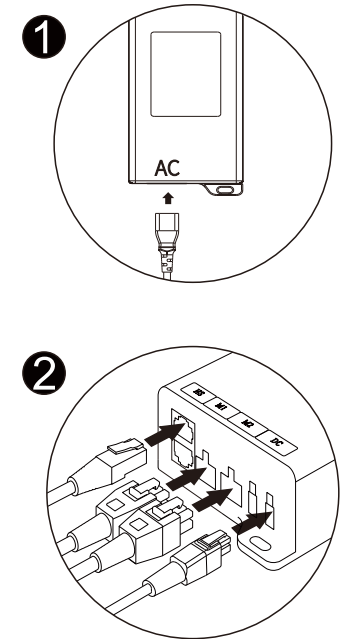
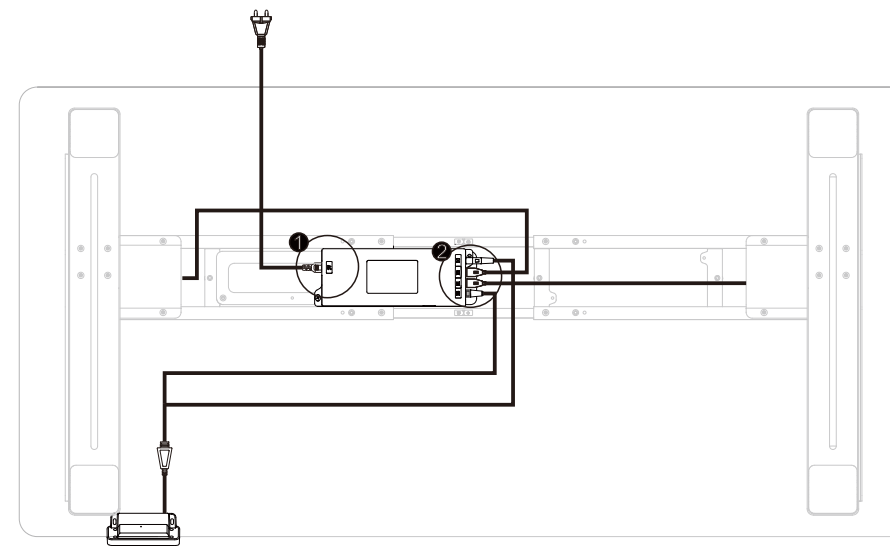
NOTE:
Please note the orientation of the table legs when installing.



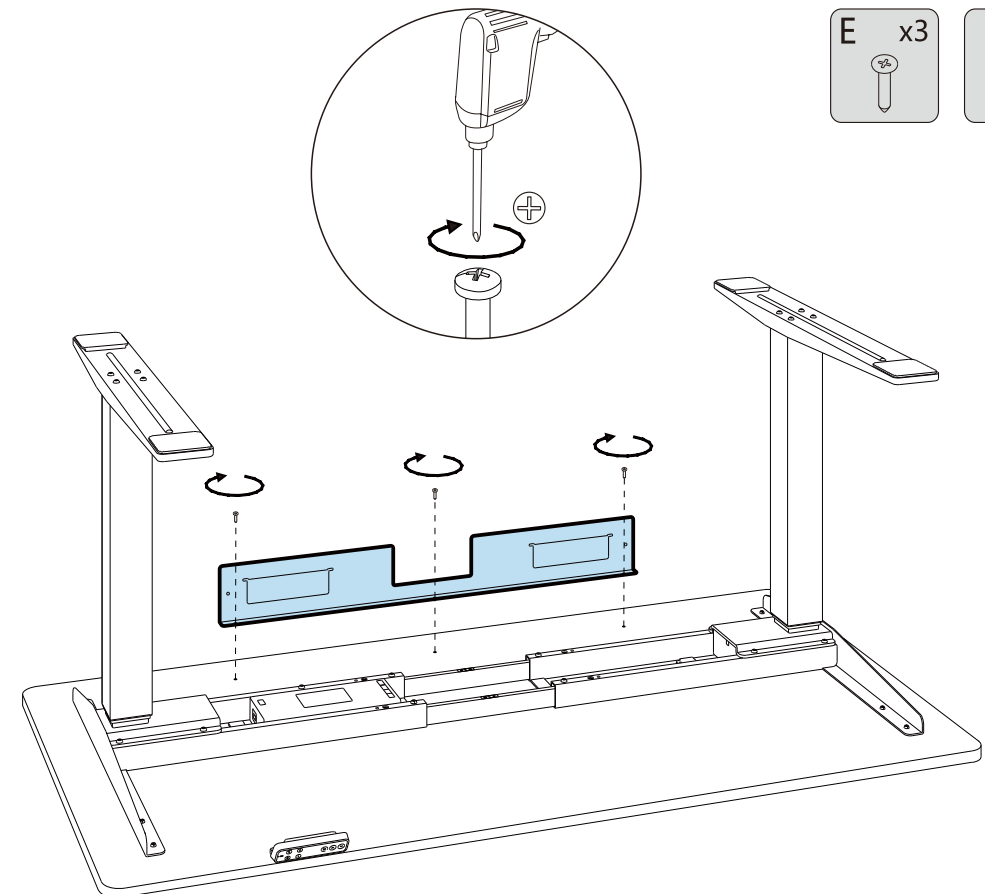
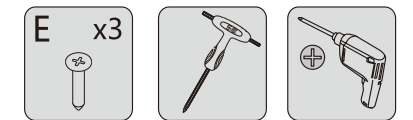
6 Fix the keypad



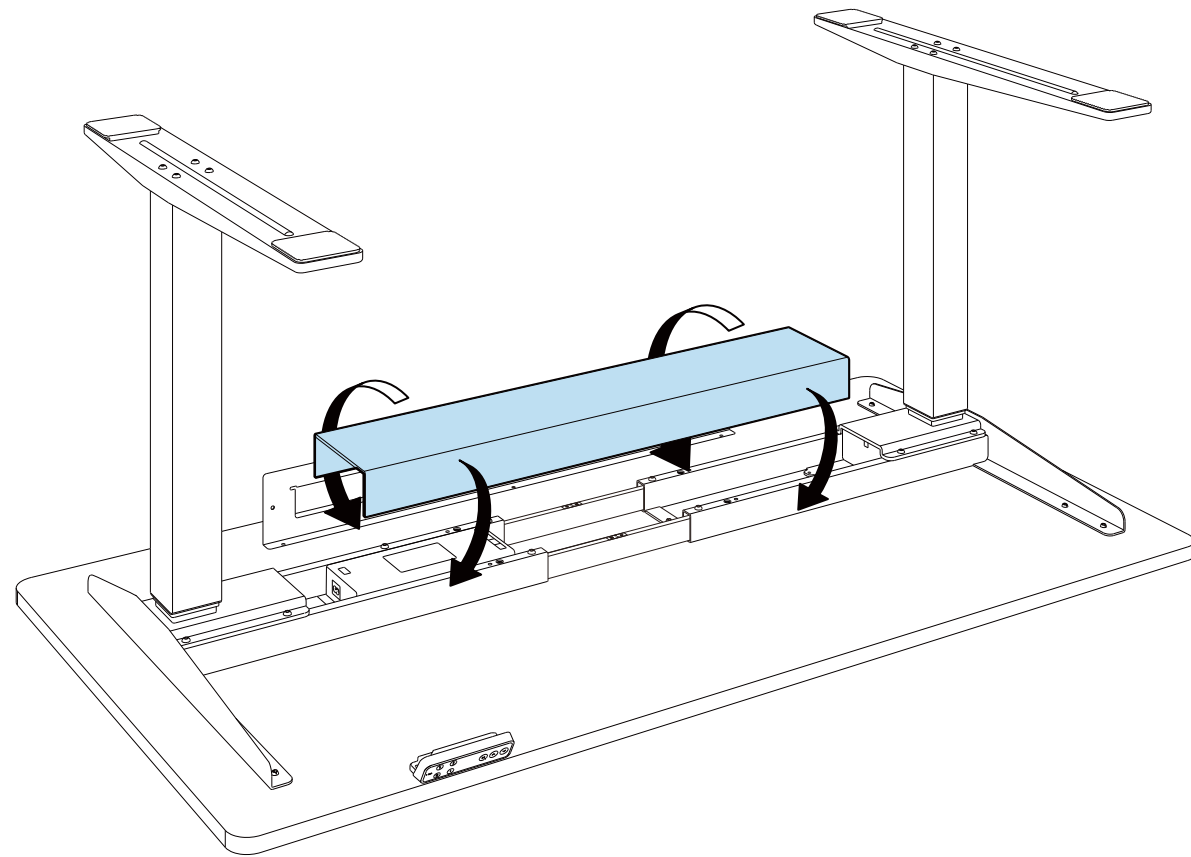
7 Connect the wires



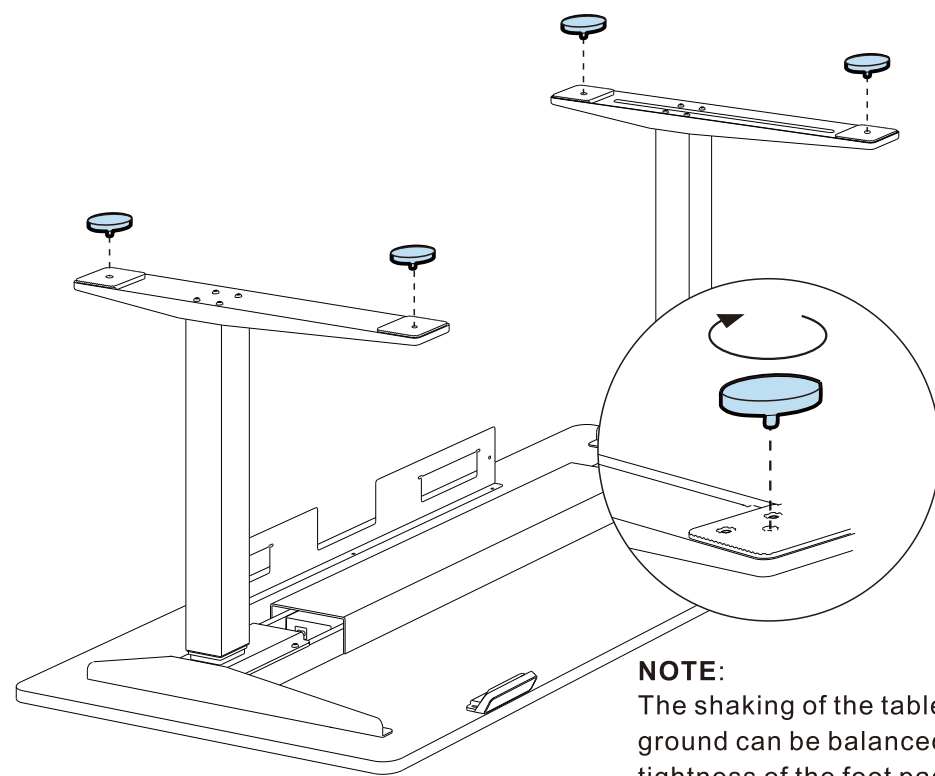
8 Attach the cable tray



9 Attach the cable tray

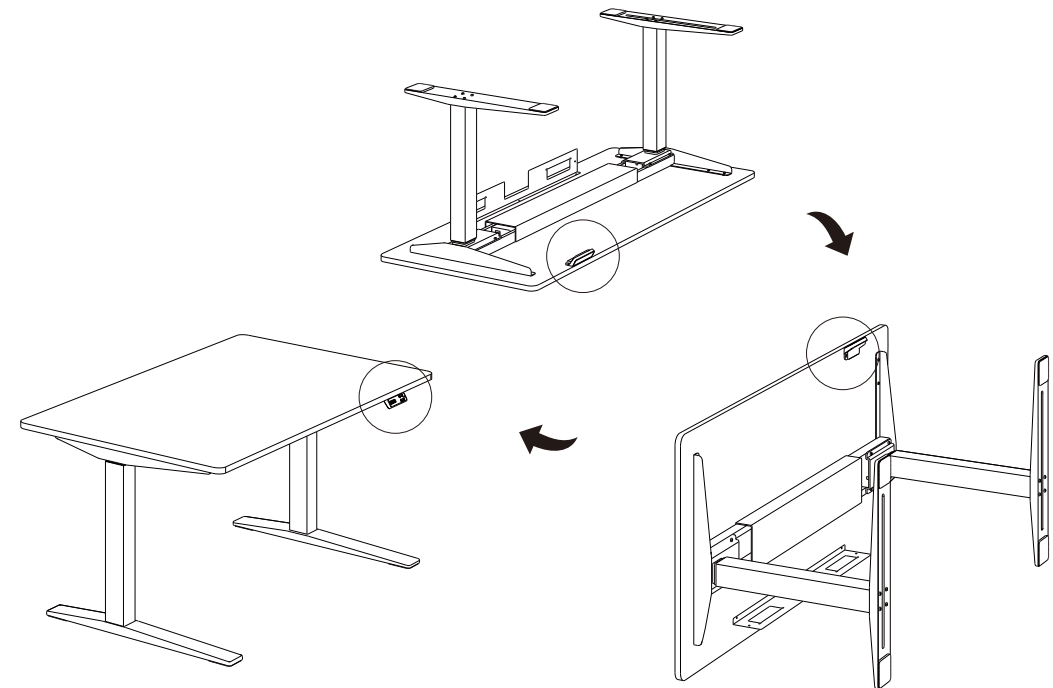


10 Adjust foot pads for balance

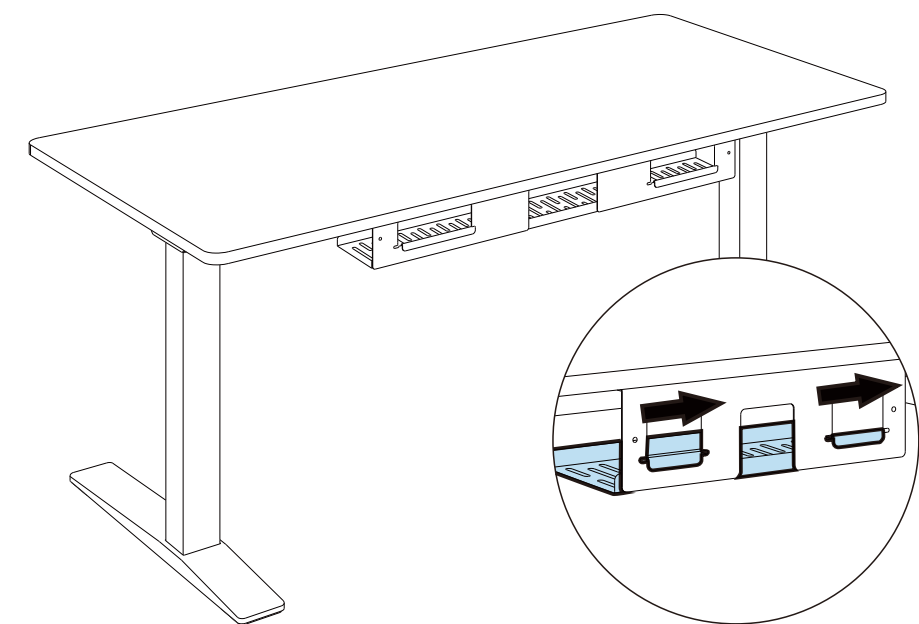


NOTE:
The shaking of the table due to the uneven ground can be balanced by adjusting the tightness of the foot pads. This step is installed according to the situation.

11 Finished



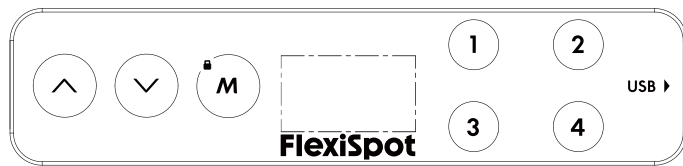
12



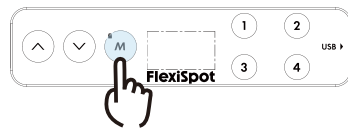
NOTE:
Cable ties total length 2m, not disposable use product, when you need to tidy up the cable, cut it to a suitable length.



13 Keypad User Guide

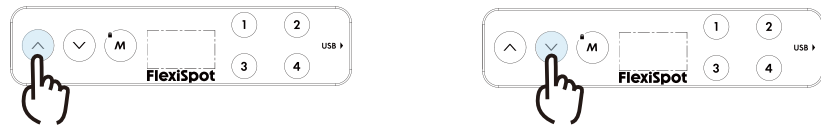


• Child lock function:



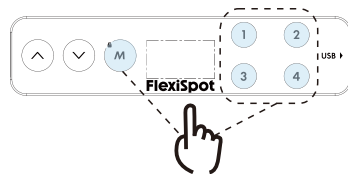
- When the child lock is turned on, the child lock blue indicator light (V and M directly above) lights up.
- Press the button indicator to flash once.
- To unlock or start the child lock, you need to press and hold the M button for about 5 seconds.
- Only when the child lock is unlocked, all the buttons can work normally.

• Height Adjustable Function:



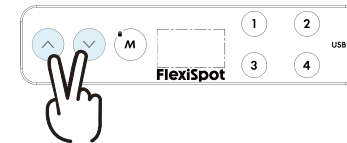
Press the "∧" or "∨" button to adjust the height. The LED display shows the current height.

• Height Memory Function:



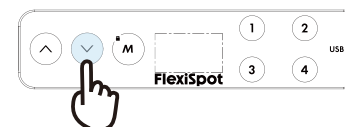
- Press UP or DOWN button and adjust the height to the desired height. Press "M" to save the height, and the screen will display "5- 1"; Press "1", "2", or "3", "4" then, that is, save the height to the corresponding position 1 or 2 3, or 4, which will show in the display screen as "5- 1", "5-2", or "5-3", or "5-4";
- Press "1", "2" and "3", "4" button directly to automatically adjust the memory height you saved.

• Collision prevention sensitivity adjustment - optional features:



- Press and hold the "∧" "∨" button for 5 seconds at the same time to switch the sensitivity. There are four levels of sensitivity (A-3, A-2, A-1, A-0). Each operation will switch the sensitivity into the next level.
- The display shows "A-0", the anti-collision function is off; the display shows "A-1", low sensitivity; Display shows "A-2", medium sensitivity; display shows "A-3", high sensitivity;
- During height adjustment, when tabletop comes in contact with another object, it instantly stops and reverses to avoid damage.
- Press and hold the "∧" "∨" button for 5 seconds at the same time. If the display does not display the above code, there is no anti-collision function.

• Troubleshooting:



- Reset: When the LED shows "R5f", press "∨" button until the desk reaches its lowest height and rebounds to stop, it means the reset has been finished.
- When it doesn't work and the LED shows "E01" or "E02", please retry 18 mins later.
- If the "∨" button doesn't work, please check the cable connection and then cut off the power for at least 10 seconds. Reconnect to the power and press "∨" button to start the reset process when it shows the "R5f".
- If all these above process are inefficient, plz contact our customer service.

14 Resolving Common Issues

The following tips will help you identify and correct common issues. If you encounter an issue not listed in the table below, or if you follow the instructions below and the issue is still not resolved, please contact your supplier. All such anomalies or errors can only be investigated and corrected by the manufacturer or specially trained personnel.

Issue	Solution
Electronic functions are not working properly	Verify cables are connected correctly
Slow ascent	Check whether the desk load is too heavy (over 440 lbs)
Desktop slips during ascent	
Keypad often goes into reset state	
Keypad often goes into reset state	Reset the desk
Desk does not rise or lower the full distance	
Desk remains at lowest height	
Desk motor has been running for more than 18 minutes	Let the desk idle for 18 minutes with the power connected
Press the down button and the device does not drop but rises	Check for obstructions under the table or if the harness is hanging down

15 Attention

- Power supply: AC100V - 240V, frequency 50/60HZ;
- Working environment: 0 - 40°C;
- Before cleaning, you have to unplug the power supply cable. Clean with a slightly damp cloth to wipe away the surface dust. Keep all electrical components away from liquids. Do not damage the connection line and keep the plug in a safe position.
- Inside the control box, there are electronic components, metal parts, plastic parts, wires and so on. They should be disposed in accordance with the local laws and regulations. They cannot be disposed as household waste.
- Before using the product, please make sure the product has been installed correctly.
- Before starting use of the product, please read the instructions to fully understand all the product's functions and settings.
- Keep children away from electric height-adjustable desks, control units and handsets. Manufacturer is not responsible of any damages that result from children's unpredictable behaviour.
- Slight noise caused by the multi wedge belt or brake system will not impact the use of this product.
- Do not use corrosive or abrasive materials to clean this product and please dispose of cleaning solutions in an environmentally friendly manner.
- Understand the risks associated with using this product. Children or those with cognitive impairment should not use this product without supervision.
- If the power supply cord is damaged or broken, it must be replaced by the manufacturer or a relevant specialist to avoid any injuries.
- Please operate in a clean and safe environment. For example, do not left around your tools. And always be careful to deal with packaging materials, in order to avoid any kinds of possible danger. Potential choking risk exists when children play with plastic bags!
- If necessary, retain the original package for future transportation.

16 Recycling and Disposal

This product cannot be disposed of as household waste. To prevent damage to the environment, this product should be recycled. Please use the relevant recycling systems available to you or contract the distributor or manufacturer for recycling assistance.

FlexiSpot Limited Warranty

This limited warranty offered by FlexiSpot covers defects in material or workmanship in new FlexiSpot products. This warranty extends to the original purchaser only and is non-transferable. Only consumers purchasing FlexiSpot products from authorized FlexiSpot retailers or resellers may benefit from our limited warranty.

What is Covered?

The FlexiSpot limited warranty covers our products against defects in material or workmanship as follows:

·FlexiSpot Height Adjustable Desk Frames

15 years: all metal and mechanical parts and components, including motors and electrical components of FlexiSpot Standing Desk E7 series.

10 years: all metal and mechanical parts and components, including motors and electrical components of FlexiSpot Standing Desk E5 series.

5 years: all metal and mechanical parts and components, including motors and electrical components of all other height adjustable desk except for E5, E7 series.

·FlexiSpot Sit-Stand Desktop Workstations

All standing desks purchased on or after October 5, 2016 include a 5-year warranty for the frame, medium-fiber desktop and mechanisms.

·FlexiSpot Desk Bikes

All desk bikes purchased on or after October 5, 2016 include a 3-year warranty for the frame, and a 1-year warranty for the electronics and other mechanisms.

·FlexiSpot Mini Steppers

All desk bikes purchased on or after October 5, 2016 include a 1-year warranty for the frame, and other mechanisms.

·Accessories

All monitor mounts purchased on or after October 5, 2016 include a 5-year warranty for the arms, 3-year warranty for gas spring system and mechanisms.

What are your Remedies?

FlexiSpot will replace at no charge to the consumer the defective parts only or, at FlexiSpot's option, replace any product or part of the product that is defective because of improper workmanship and/or material, under normal installation, use, service and maintenance. If FlexiSpot is unable to provide a replacement and repair is not practical or cannot be completed in a timely fashion, FlexiSpot may elect to refund the purchase price in exchange for the return of the product. In the rare event that your FlexiSpot product is defective, we will provide you with a replacement item shipped at no cost to you within the continental United States. The shipping method for replacement products is FedEx Ground, but expedited shipping is available if you choose to pay the additional expense. In addition, you will need to pay the shipping costs if any products need to be shipped to you at an address outside the continental United States.

REPAIR OR REPLACEMENT (OR, IN LIMITED CIRCUMSTANCES, REFUND OF THE PURCHASE PRICE) AS PROVIDED UNDER THIS WARRANTY IS THE EXCLUSIVE REMEDY OF THE PURCHASER. FLEXISPOT NEITHER ASSUMES NOR AUTHORIZES ANY PERSON TO CREATE FOR IT ANY OTHER OBLIGATION OR LIABILITY IN CONNECTION WITH THIS PRODUCT.

FlexiSpot Limited Warranty

What is Not Covered?

Our limited warranty does not cover any problem that is caused by:

1. Conditions, malfunctions or damage not resulting from defects in material or workmanship.
2. Conditions, malfunctions or damage resulting from normal wear and tear, improper installation, improper maintenance, misuse, abuse, negligence, accident or alteration.
3. Accessories, connected materials and products, or related products not manufactured by FlexiSpot.
4. Conditions, malfunctions or damage resulting from failure to follow the instructions and guidelines relating to the product's intended use.

Our limited warranty is void if a product is returned with removed, damaged or tampered labels or any alterations (including removal of any component or external cover).

How to File a Claim?

In order to receive the benefit of our limited warranty, you need to process your claim in compliance with the terms of this limited warranty and follow proper return procedure. To request warranty service, please contact customer service via email at contact@FlexiSpot.com or toll free at 1-855-585-5618. You will need to provide the sales receipt or other evidence of the date and place of purchase for your FlexiSpot product.

Implied Warranties and Limitation of Damages

EXCEPT TO THE EXTENT PROHIBITED BY APPLICABLE LAW, ALL IMPLIED WARRANTIES (INCLUDING WARRANTIES OF MERCHANTABILITY AND FITNESS FOR A PARTICULAR PURPOSE) SHALL BE LIMITED IN DURATION TO THE DURATION OF THIS WARRANTY, AND FLEXISPOT SHALL NOT BE LIABLE FOR ANY INCIDENTAL, INDIRECT, SPECIAL, OR CONSEQUENTIAL DAMAGES, INCLUDING BUT NOT LIMITED TO LOSS OF PROFITS OR REVENUE, RESULTING FROM ANY BREACH OF EXPRESS OR IMPLIED WARRANTY OR CONDITION, OR UNDER ANY OTHER LEGAL THEORY, EVEN IF FLEXISPOT HAS BEEN ADVISED OF THE POSSIBILITY OF SUCH DAMAGES. Some jurisdictions do not allow limitations on the duration of an implied warranty or the exclusion or limitation of special, indirect, incidental or consequential damages, so the above limitations or exclusions may not apply to you.

Governing Law

This Warranty shall be governed by the laws of the State of California, USA, without giving effect to any conflict of laws principles that may provide the application of the law of another jurisdiction.

How State Law Applies

This Warranty gives you specific legal rights, and you may also have other rights which vary from state to state.