

# QuickStand™

INSTALLATION INSTRUCTIONS



# PARTS REQUIRED

## Single QuickStand Parts





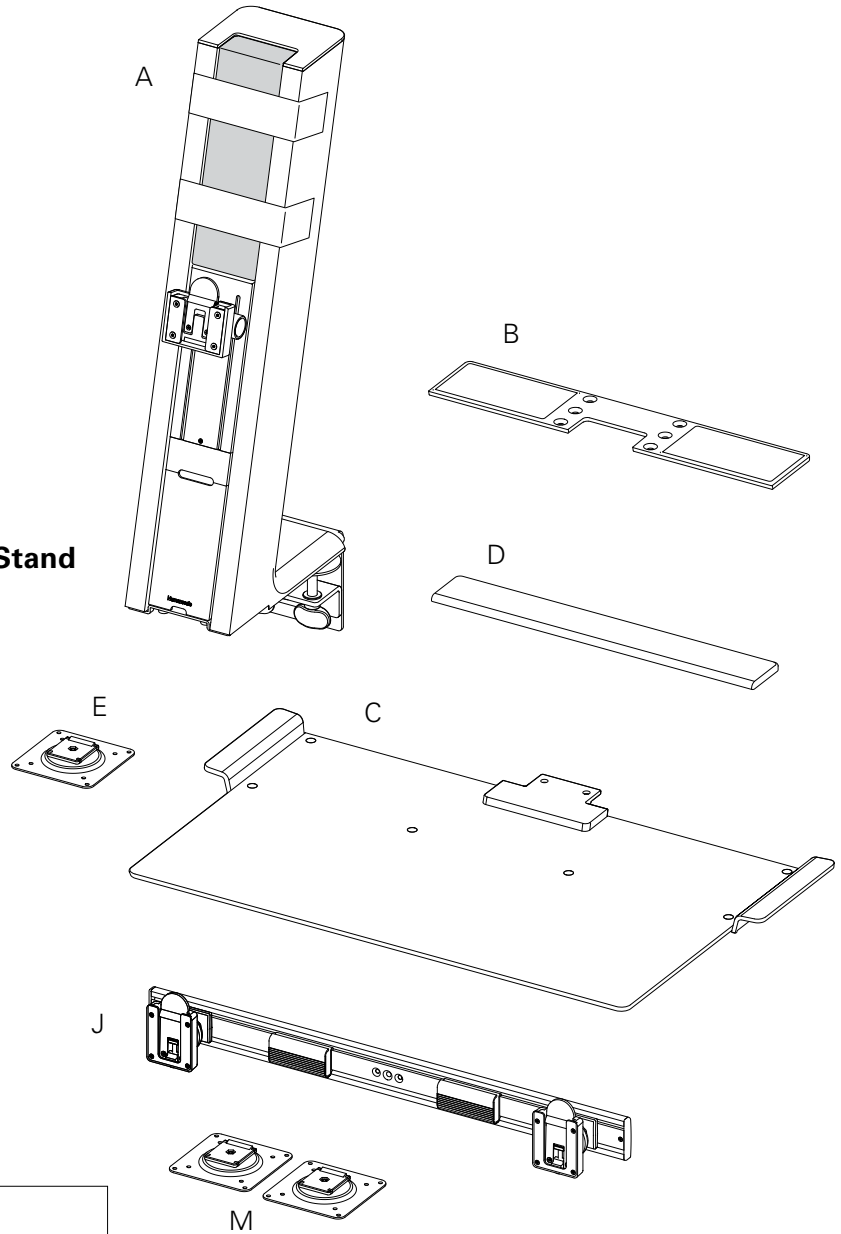

- A (1) QuickStand Unit
- B (1) Base Plate
- C (1) Platform
- D (1) Palm Support
- E (1) VESA Plate
- F (6) M8 x 18 mm Flat Head Machine Screws
- G (4) M4 x 18 mm Pan Head Phillips
- H (4) M4 x 8 mm Pan Head Phillips
- I (4) VESA Spacer

## Additional Parts for Dual Monitor QuickStand





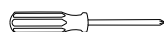

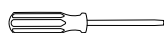

- J (1) Dual Monitor Crossbar
- K (1) M6 x 22 mm Flat Head Machine Screws
- L (2) M5 x 18 mm Flat Head Machine Screws
- M (2) VESA Plate
- N (8) M4 x 18 mm Pan Head Phillips
- O (8) M4 x 8 mm Pan Head Phillips
- P (8) VESA Spacer



## Tools Required

- |   |   |
|---|---|
|  |  |
| 3 mm Hex Key (supplied)   | Box Knife   |
|  |  |
| 4 mm Hex Key (supplied)   | Tape Measure  |
|  |  |
| 5 mm Hex Key (supplied)   | #2 Phillips Screwdriver   |
|  |  |
| 6 mm Hex Key (supplied)   | Flat-Head Screwdriver   |

## Hardware

- |  |   |
|--|---|
| F  | K  |
| G  | L  |
| H  | N  |
| I  | O  |
|  | P  |

## WARNING

Read all instructions carefully before installing this product or attempting to use it

This product contains a loaded mechanism that is under tension. Do not attempt to remove or alter any part of this product or in any way modify or tamper with any component of this product other than as set forth in these instructions. Failure to comply with the instructions provided may result in property damage or serious injury.

Do not remove bracing box attached to QuickStand unit until your QuickStand is fully assembled

## STEP 1

### Remove Shipping Plate

Tools: 6 mm Hex Key

- Lay the QuickStand unit on the work surface facing up and unscrew the (2) M8 x 10 mm Cap Head Machine Screws holding the Shipping Plate in place (fig. A)
- Set aside the (2) M8 x 10 mm Cap Head Machine Screws and the Washers for Step 3

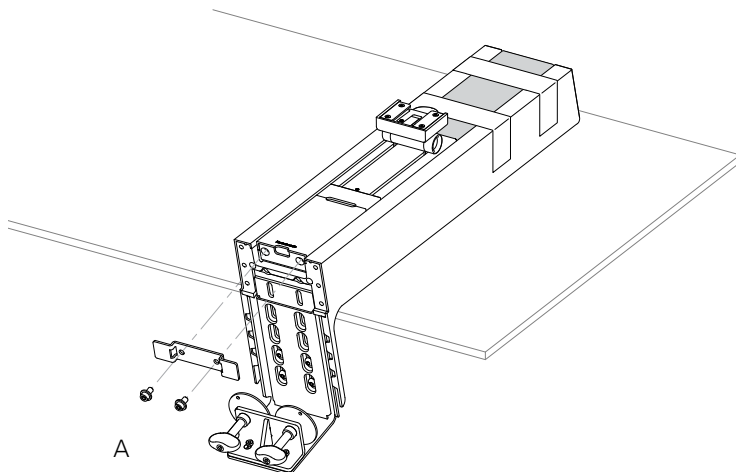

## STEP 2

### Attach Base Plate

Tools: 5 mm Hex Key

- Secure the Base Plate in place using (6) M8 x 18 mm Flat Head Machine Screws (fig. B)

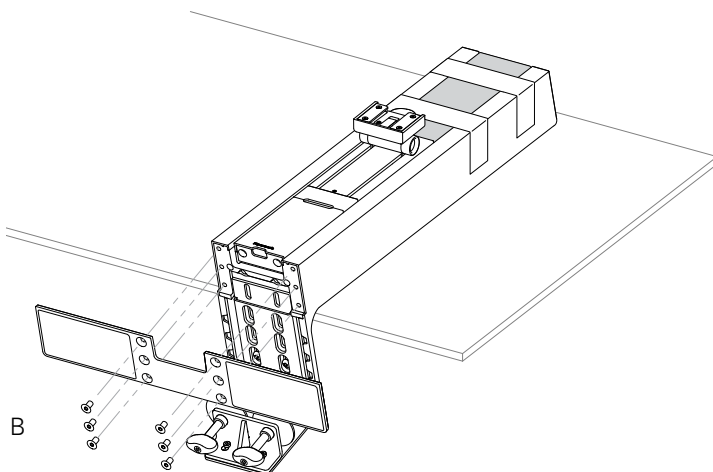

## STEP 3

### Attach Platform

Tools: 6 mm Hex Key

- Ensure the Platform is equally spaced from the Base Plate on either side (fig. C)
- Using the (2) M8 x 10 mm Cap Head Machine Screws and the Washers from step 1, secure the Platform to the QuickStand unit

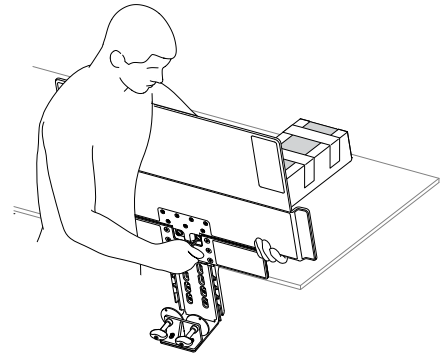
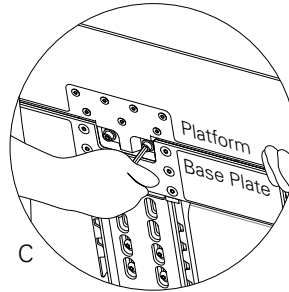

## STEP 4

### Measure Work Surface Depth

**IMPORTANT:** Please check the depth of your work surface

- If you are installing a QuickStand with a Large Platform, your QuickStand is pre-set to attach to a 29" (750 mm) deep work surface
- If you are installing a QuickStand with a Small Platform, your QuickStand is pre-set to attach to a 23" (600 mm) deep work surface

Tools: Measuring Tape

- The distance between the front edge of the Platform to the inside face of the Base Clamp must be equal to the work surface depth (fig. D)
- If the Base Clamp is in the correct position, please proceed to step 6
- If the Base Clamp needs to be adjusted, please proceed to step 5

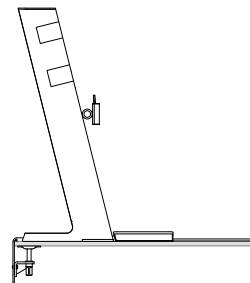
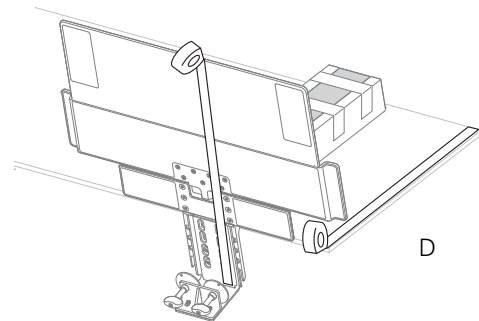

## STEP 5

### Adjust Base Clamp for Correct Work Surface Depth

Tools: Measuring Tape  
5 mm Hex Key

- Loosen or remove the (4) M8 x 10 mm Pan Head Machine Screws and slide/reposition the Base Clamp to achieve the correct work surface depth (fig. E)

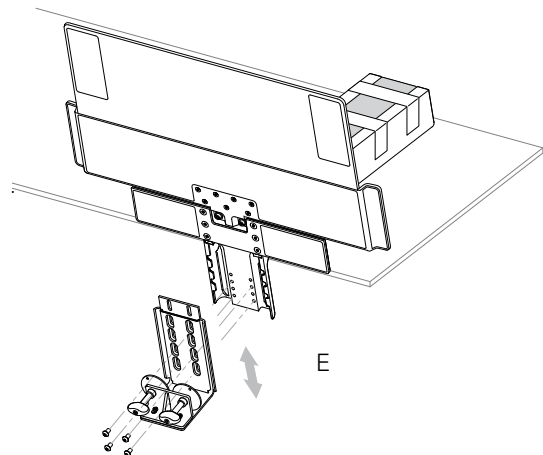

## STEP 6

### Attaching QuickStand to the Work Surface

**IMPORTANT:** Your QuickStand unit is heavy. If needed, please have assistance when lifting.

- Carefully lift your QuickStand unit from its horizontal position to its vertical position (fig. F)
- Tighten the two thumbscrews to clamp your QuickStand unit to the back edge of the work surface

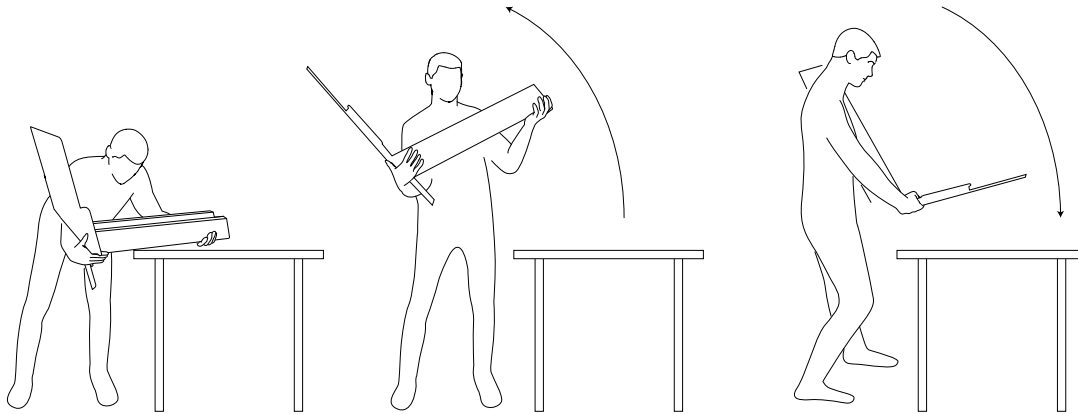
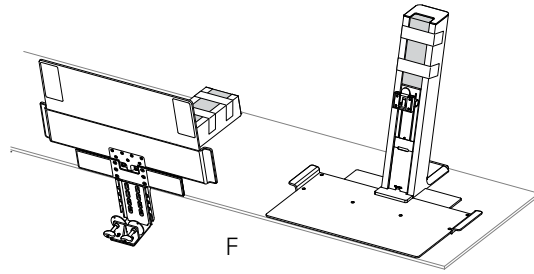

## STEP 7

### Mounting Single Monitor

If you are installing a dual QuickStand unit please proceed to Step 8

Tools: #2 Phillips Screwdriver

- Make sure the top of the VESA Plate is facing towards the top of the monitor before securing
- Screw down the VESA Plate using the hardware kit supplied (fig. G)
- Slide the monitor into the quick-connector on the QuickStand unit (fig. H)
- Plug the Power Cord and DVI Cable into the monitor
- Once your monitor is in position, please proceed to Step 10

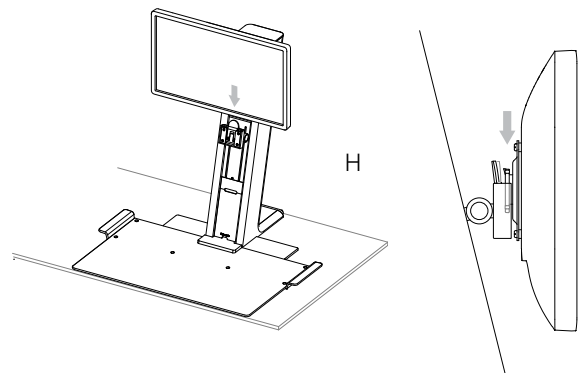
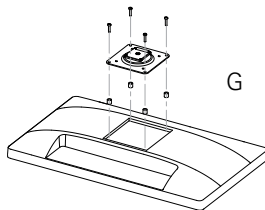

## STEP 8

### Attaching Crossbar for Dual Monitors

Tools: 3 mm Hex Key  
4 mm Hex Key

- Attach Dual Monitor Crossbar to QuickStand unit using the hardware kit supplied (fig. I)

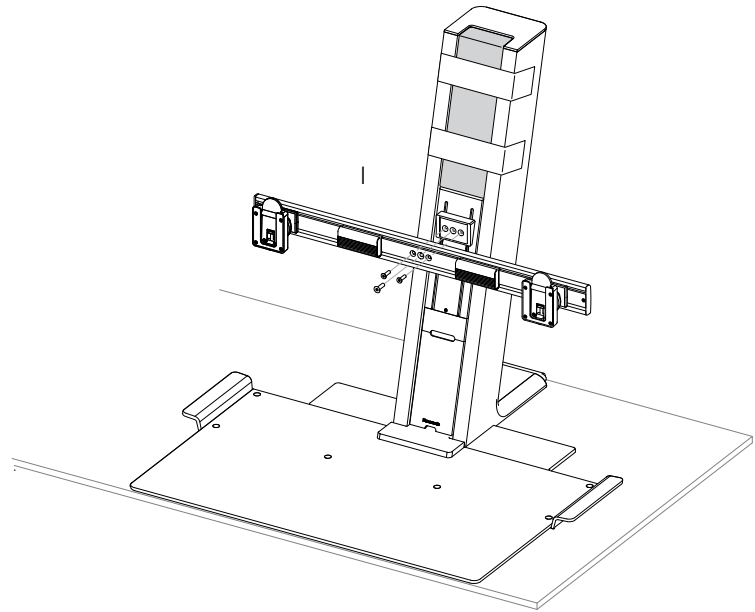

## STEP 9

### Attaching Dual Monitors

Tools: #2 Phillips Screwdriver

- Make sure the top of the VESA Plates are facing towards the top of the monitor before securing
- Screw down the VESA Plates using the hardware kit supplied (fig. J)
- Slide each monitor into the quick-connector on the Dual Monitor Crossbar (fig. K)
- Plug the Power Cord and DVI cable into each monitor

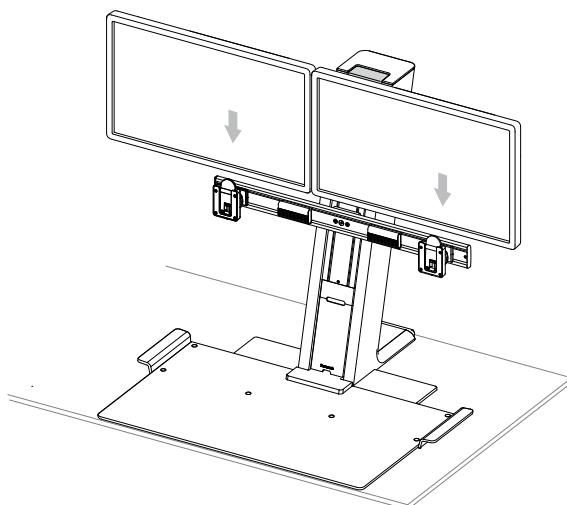
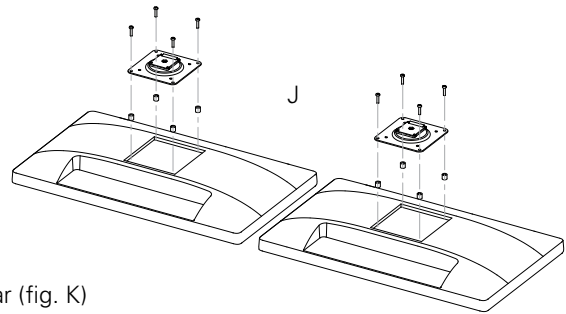

K

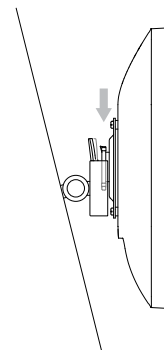

## STEP 10

---

### Secure Palm Support

- Peel off sticker backing from Palm Support and place down in your desired position on the front edge of the Platform (fig. L)

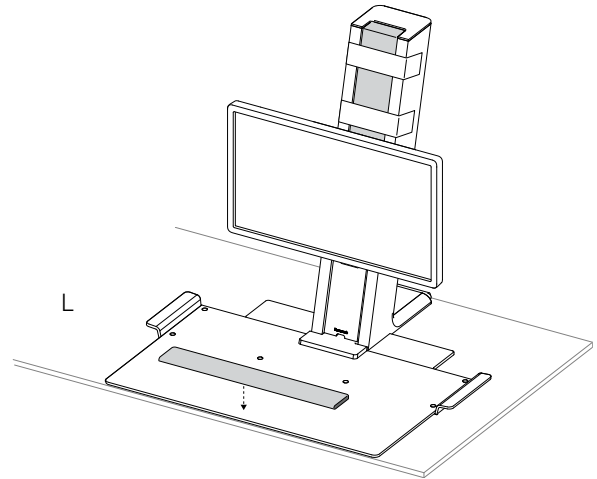

## STEP 11

---

### Attaching USB Devices

Tools: Flat-Head Screwdriver

- Using a Flat-Head Screwdriver if needed, remove cable cover by tilting out from the bottom (fig. M)
- Route USB cables from keyboard and mouse into cable bracket (fig. N)
- Carefully pull cable slack through bracket until cable heads are set within. Wrap remaining cable slack around bracket (fig. O)
- Replace cable bracket cover (fig. P)

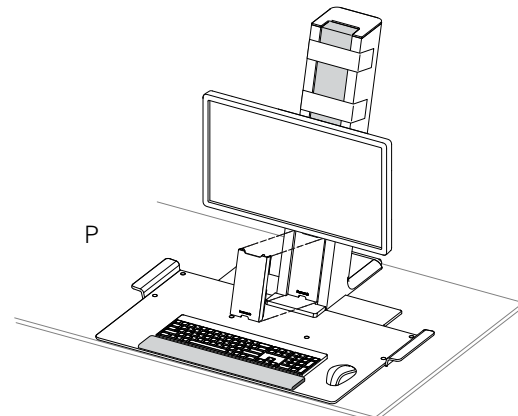
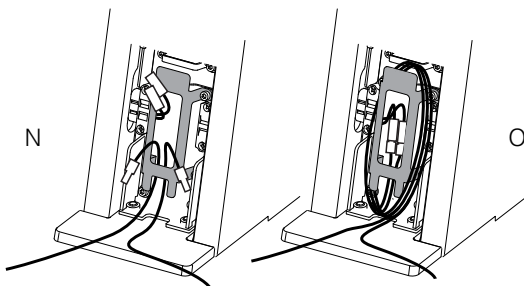
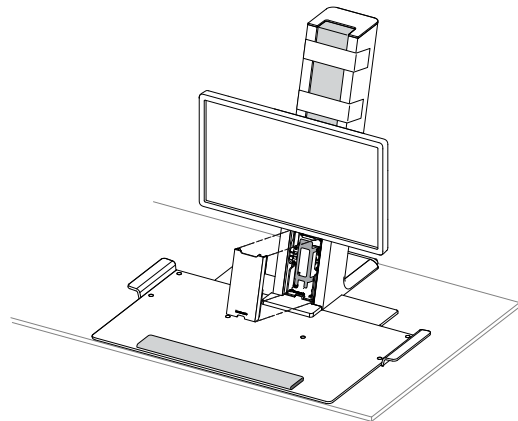
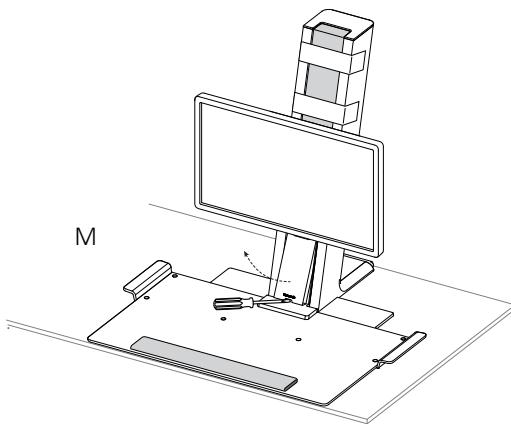

## STEP 12

### Removing Brace Box

- Remove tape and lift out box. (fig. Q)

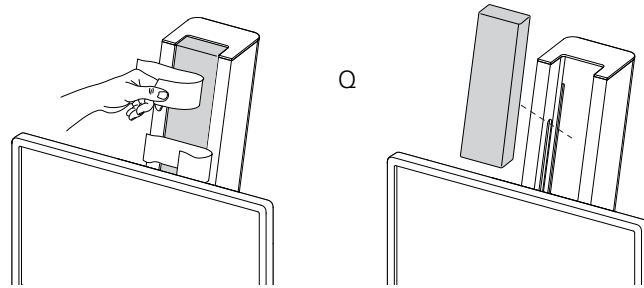

## ADJUSTING QUICKSTAND

In order to be able to raise and lower your QuickStand with ease, it is important to spend some time adjusting the tension adjuster which can be located in the top of the QuickStand unit

## STEP 13

### Adjusting Weight Capacity

**WARNING:** Do not use a Power Drill to adjust the tension adjuster

Tools: 6 mm Hex Key

- Remove top cover from QuickStand unit to expose the tension adjuster screw (fig. R)
- Slowly begin to turn the tension adjuster screw clockwise to increase the tension (fig. S)
- We recommend turning the tension adjuster screw 10 revolutions at a time before checking to see if your QuickStand is correctly balanced
- Once you have adjusted your QuickStand, try raising and lowering a few times until it fluidly adjusts. Your QuickStand should stay where you set it
- If you need to make further adjustments, please follow these steps again

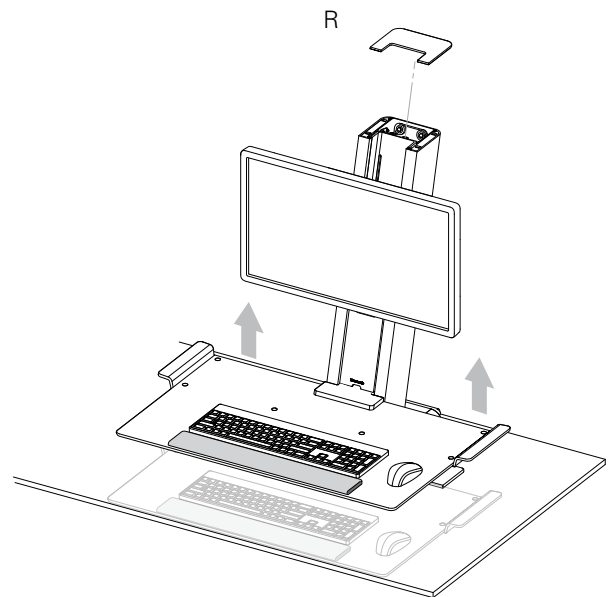

**+** **Increase Weight Capacity** – If the platform is too heavy to raise but easy to lower and does not stay in place when raised, please adjust the tension adjuster

**-** **Decrease Weight Capacity** – If the platform is too easy to raise but difficult to lower and does not stay in place when lowered, please adjust the tension adjuster

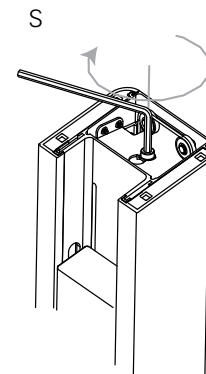



# STEP 14

## Adjusting Monitor Height

### SINGLE QUICKSTAND

- Hold each side of your monitor and manually raise or lower until it is in the correct position (fig. T)

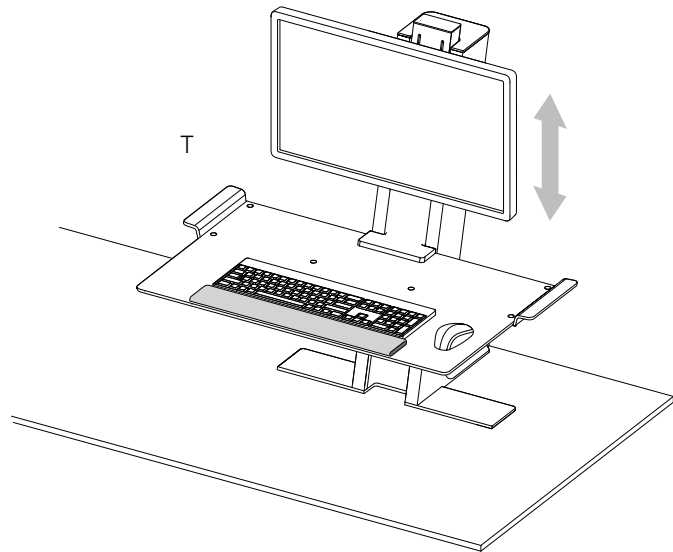

### DUAL QUICKSTAND

Tools: 6 mm Hex Key

- Remove top cover of the carriage assembly (fig. V)
- Slowly begin to turn the monitor height adjustment screw clockwise to raise the monitors and counter-clockwise to lower the monitors (fig. W)

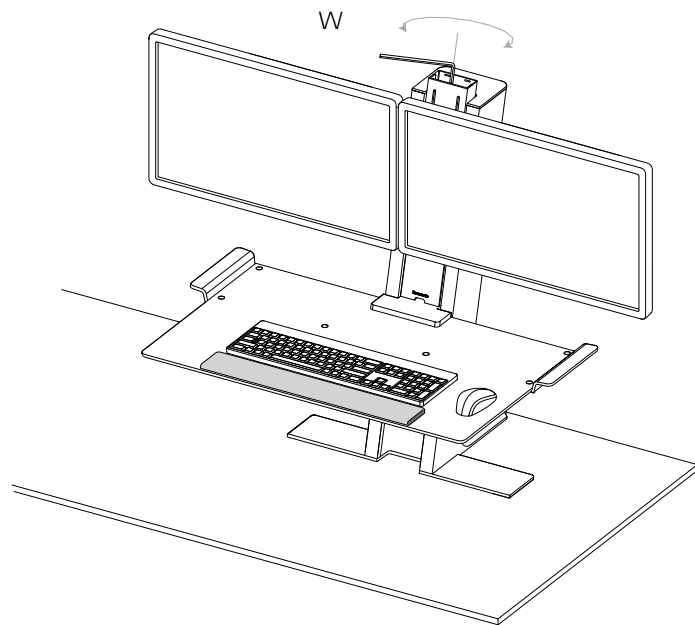
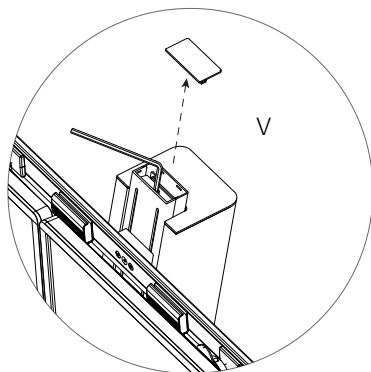

## STEP 15

---

### Adjusting Monitor Tilt

#### SINGLE AND DUAL QUICKSTAND

- Hold the top and bottom of your monitor and manually adjust the monitor tilt until the desired angle is achieved (fig. X)

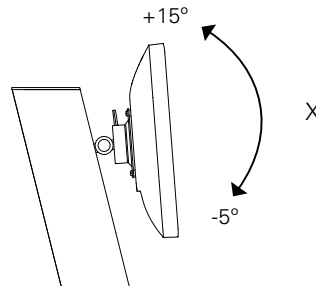

## STEP 16

---

### Adjusting Monitor Orientation

#### SINGLE AND DUAL QUICKSTAND

- Hold each side of your monitor and manually turn the monitor until the desired orientation of either landscape or portrait is achieved (fig. Y)

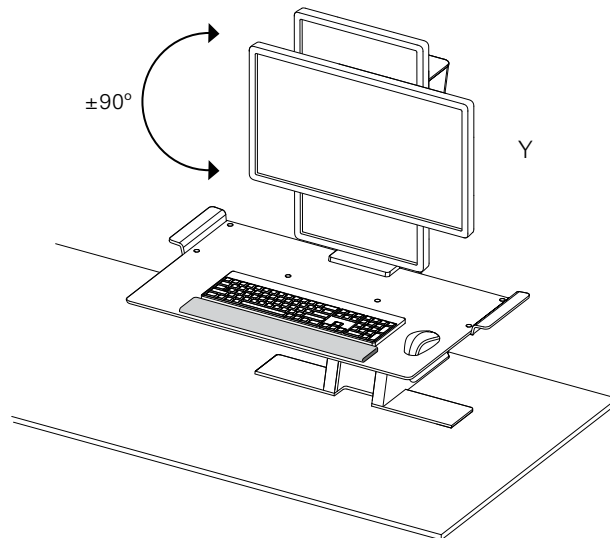

## STEP 17

---

### Correctly Setting Up Your Workstation

#### SINGLE AND DUAL QUICKSTAND

- Adjust the platform until the keyboard is at or just below elbow height
- If needed, manually adjust the monitor up or down until the top line of text on the screen is at eye level

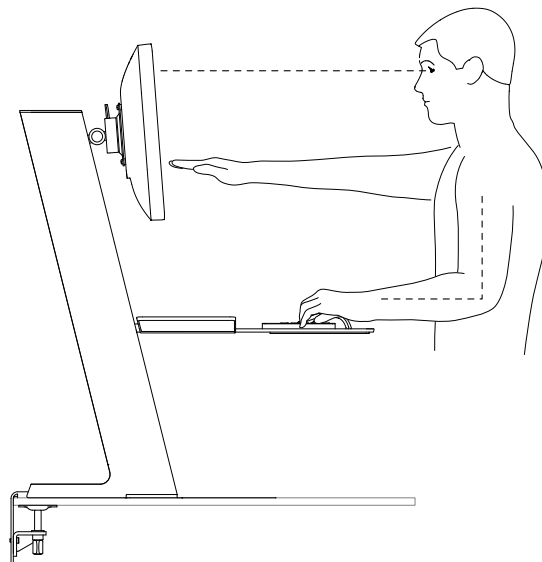



HSR0514