

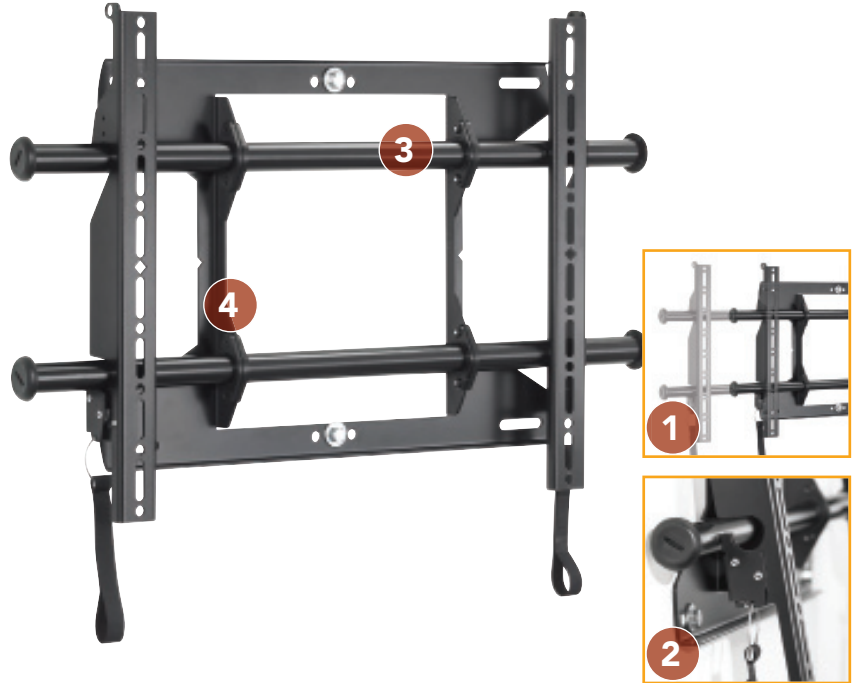

FEATURES

- 1 CENTERLESS™ SHIFT**
Provides up to 14.5" of post-installation lateral shift – 7.25" left/right of uprights – for limitless centering capabilities.
- 2 CLICKCONNECT®**
Hear an audible click when the screen safely engages with the mount. A built-in cable stand provides easy access under the screen.
- 3 CUSTOMIZABLE ACCESSORY SYSTEM**
A full line of supporting accessories can be integrated with the mount, extending the same adjustment benefits to the entire configuration.
- 4 MULTIPLE INSTALLATION OPTIONS**
Installation options include: single- or dual-stud mounting on 16" centers.



SPECIFICATIONS

Depth from Wall	1.96" (50 mm)
Max Lateral Shift	14.5" (368 mm)
Dimensions (HxWxD)	13.5" x 25.44" x 1.96" (343 x 646 x 50 mm)
Max Mounting Pattern	15.75" (400 mm), height 25.2" (640 mm), width
Weight Capacity	75 lbs (34 kg), single stud 125 lbs (57 kg), dual stud
Color	Black

WHAT YOU NEED TO KNOW

ORDERING OPTIONS

Available in custom and universal.

OTHER PRODUCT OPTIONS



RMF1™
Fixed Rail Wall Mount
– For flat panels up to 40"

TECHNICAL DRAWINGS

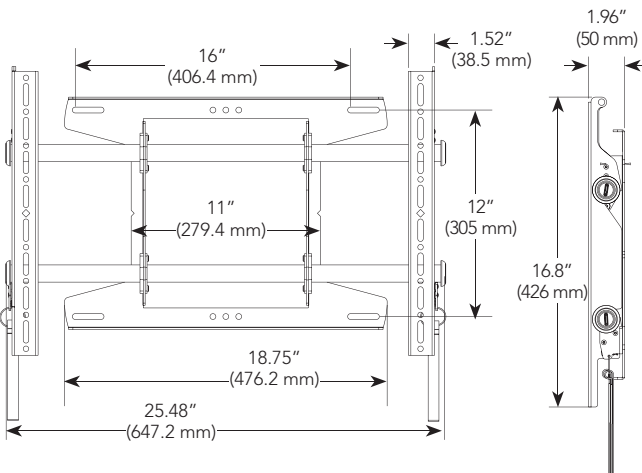

RECOMMENDED ACCESSORIES



FVS250 ■ 12" Video Conferencing Shelf
- above



FCC100 ■ Center Channel Speaker Adapters



FCS100 ■ Single Component Shelf
- below

For a complete list of FUSION mount accessories see page 87.