

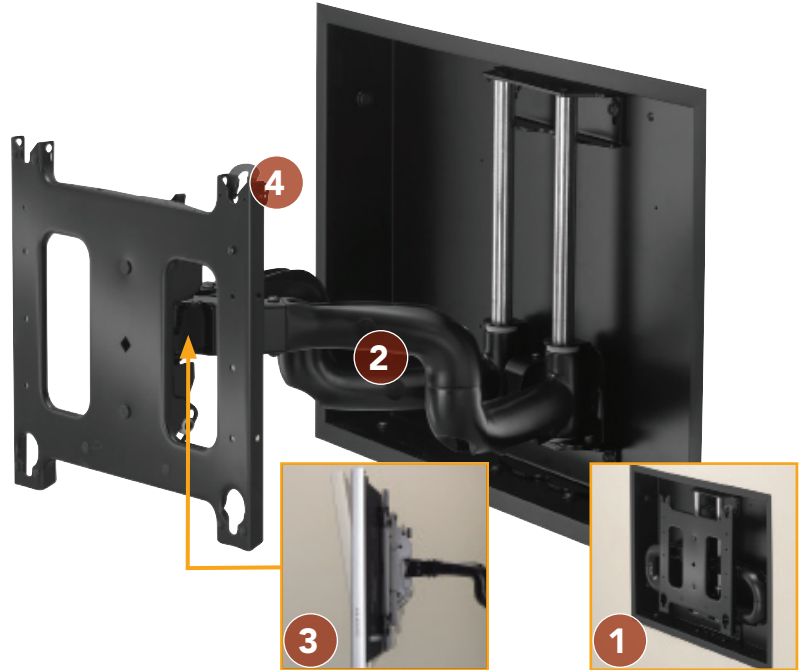

FEATURES

- 1 LOW PROFILE**
Designed to ensure mount remains concealed behind the screen.
- 2 SMOOTH EXTENSION**
Contoured swing arms are designed for effortless extension up to 22.4" (569 mm).
- 3 CENTRIS® FINGERTIP TILT**
Select the perfect tension for your screen's center of gravity to achieve smooth fingertip tilt. Screen angle stays set until you decide to readjust.
- 4 Q-LATCH® MOUNTING SYSTEM**
Flat panel secures to mount with a latching flag. Easy to connect/disconnect – no tools needed!



SPECIFICATIONS

Roll	±2°
Tilt	-15°, +5°
Swivel*	76.5° Left/Right
Extension Range	.62" - 22.4" (16 - 569 mm)
Box Dimensions (HxWxD)	20" x 30" x 3.63" (508 x 762 x 92 mm)
Color	Black
Weight Capacity	200 lbs (90.7 kg)

* With 42" flat panel. Swivel range varies with screen size.

WHAT YOU NEED TO KNOW

ORDERING INFORMATION

PAC501 and PNRIW must be ordered separately. Available in universal or custom:

- **UNIVERSAL:** Order PAC501 and PNRIWUB
- **CUSTOM:** Order PAC501, PNRIW2000B + PSBxxxx
See MountFinder™ PRO on www.chiefmfg.com for custom PSB model numbers.

STEP-BY-STEP INSTALLATION: PACHFK1™ HEADER/FOOTER KIT



TECHNICAL DRAWINGS

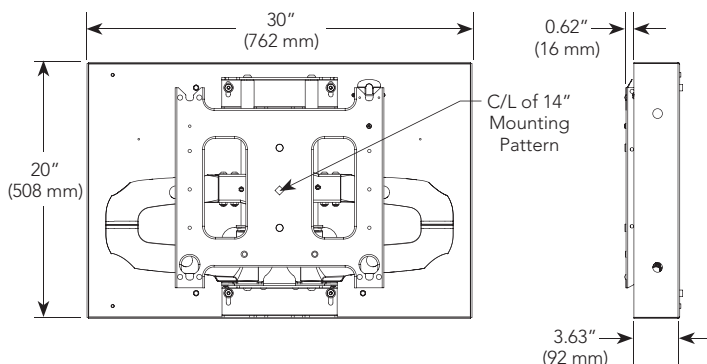

RECOMMENDED ACCESSORIES



PACHFK1 ■ Header/Footer Kit

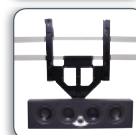

PACCC1 ■ Center Channel Speaker Adapter



PACPC1 ■ Power Filter

For a complete list of flat panel mount accessories see page 83.