

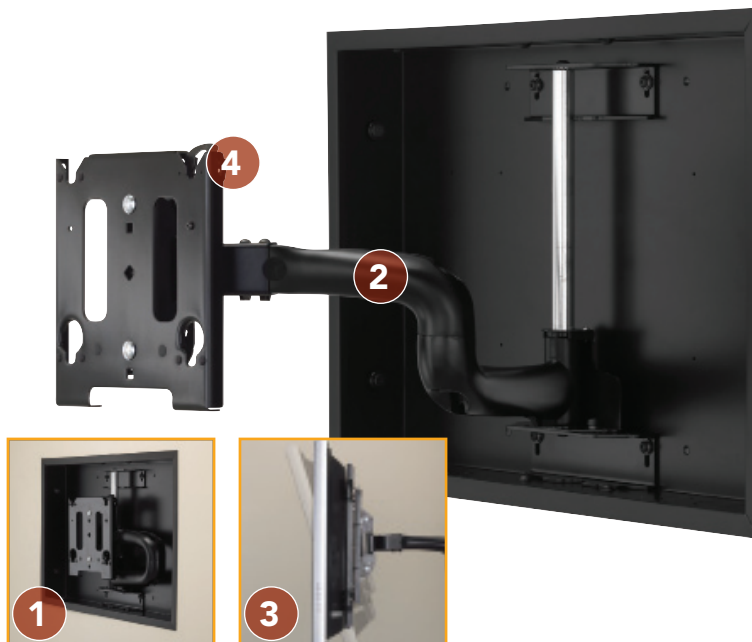

## FEATURES

- 1 LOW PROFILE**  
Designed to ensure mount remains concealed behind the screen.
- 2 SMOOTH EXTENSION**  
Contoured swing arms are designed for effortless extension up to 22" (559 mm).
- 3 CENTRIS® FINGERTIP TILT**  
Effortlessly adjust display using Centris fingertip tilt technology. Screen angle stays set until you decide to readjust.
- 4 Q-LATCH® MOUNTING SYSTEM**  
Flat panel secures to mount with a latching flag. Easy to connect/disconnect – no tools needed!



## SPECIFICATIONS

|                        |                                       |
|------------------------|---------------------------------------|
| Roll                   | ±2°                                   |
| Tilt                   | -15°, +5°                             |
| Swivel*                | 60° Left/Right                        |
| Extension Range        | 0.5" - 22" (13 - 559 mm)              |
| Box Dimensions (HxWxD) | 20" x 30" x 3.63" (508 x 762 x 92 mm) |
| Color                  | Black                                 |
| Weight Capacity        | 125 lbs (56.7 kg)                     |

\* With 42" flat panel. Swivel range varies with screen size.

## WHAT YOU NEED TO KNOW

### ORDERING INFORMATION

PAC501 and MWRIW must be ordered separately. Available in universal or custom:

- **UNIVERSAL:** Order PAC501 and MWRIWUB
- **CUSTOM:** Order PAC501, MWRIW6000B + PSBxxxx  
See MountFinder™ PRO on [www.chiefmfg.com](http://www.chiefmfg.com) for custom PSB model numbers.

### OTHER PRODUCT OPTIONS



#### PAC501™ & MWRIW™

In-Wall Box Accessory and Swing Arm Mount

## TECHNICAL DRAWINGS

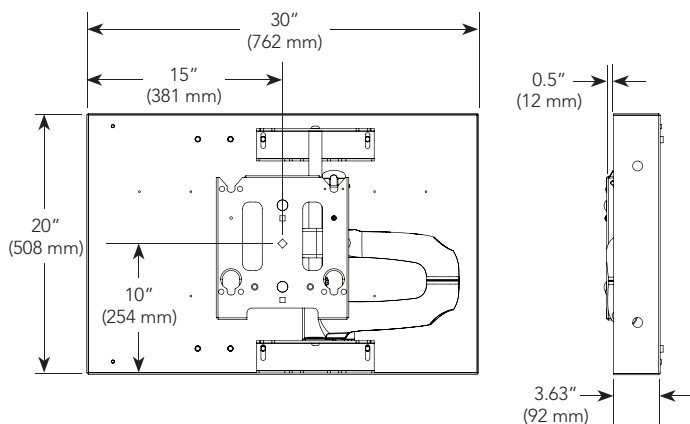

## RECOMMENDED ACCESSORIES



**PACHFK1** ■ Header/Footer Kit

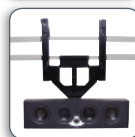

**PACCC1** ■ Center Channel Speaker Adapter



**PACPC1** ■ Power Filter

For a complete list of flat panel mount accessories see page 83.