

INSTALLATION INSTRUCTIONS

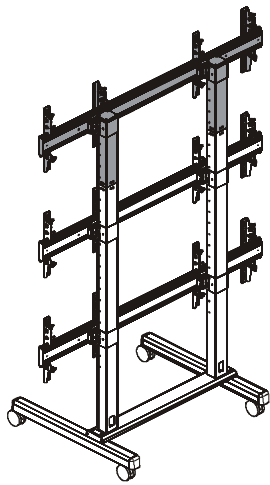

FCA2X1U

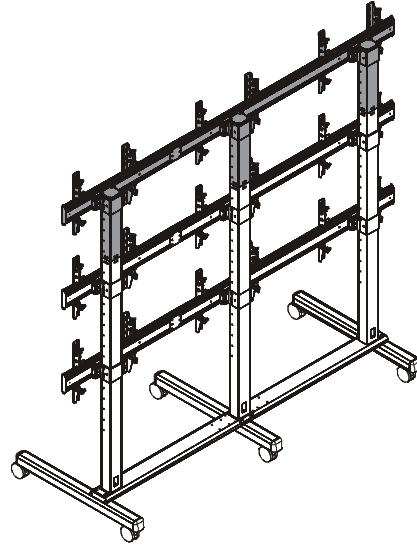

FCA3X1U

Video Wall Cart Add-On Accessories

DISCLAIMER

Milestone AV Technologies and its affiliated corporations and subsidiaries (collectively "Milestone"), intend to make this manual accurate and complete. However, Milestone makes no claim that the information contained herein covers all details, conditions or variations, nor does it provide for every possible contingency in connection with the installation or use of this product. The information contained in this document is subject to change without notice or obligation of any kind. Milestone makes no representation of warranty, expressed or implied, regarding the information contained herein. Milestone assumes no responsibility for accuracy, completeness or sufficiency of the information contained in this document.

Chief® is a registered trademark of Milestone AV Technologies. All rights reserved.



WARNING: Never operate this mounting system if it is damaged. Return the mounting system to a service center for examination and repair.



WARNING: Do not use this product outdoors.

IMPORTANT ! : For the FCA2X1U, the maximum screen width is 58" and the minimum screen width is 36". For the FCA3X1U, the maximum screen width is 46" and the minimum screen width is 36".

--SAVE THESE INSTRUCTIONS--



IMPORTANT SAFETY INSTRUCTIONS



WARNING: A WARNING alerts you to the possibility of serious injury or death if you do not follow the instructions.



CAUTION: A CAUTION alerts you to the possibility of damage or destruction of equipment if you do not follow the corresponding instructions.



WARNING: Failure to read, thoroughly understand, and follow all instructions can result in serious personal injury, damage to equipment, or voiding of factory warranty! It is the installer's responsibility to make sure all components are properly assembled and installed using the instructions provided.



WARNING: Failure to provide adequate structural strength for this component can result in serious personal injury or damage to equipment! It is the installer's responsibility to make sure the structure to which this component is attached can support five times the combined weight of all equipment. Reinforce the structure as required before installing the component.



WARNING: Exceeding the weight capacity can result in serious personal injury or damage to equipment! It is the installer's responsibility to make sure the combined weight of each display and attached accessories does not exceed 100 lbs (45.4 kg) per display or 200 lbs (90.7 kg) total for the FCA2X1U accessory and 100 lbs (45.4 kg) per display or 300 lbs (136.1 kg) total for the FCA3X1U accessory.



WARNING: Use this mounting system only for its intended use as described in these instructions. Do not use attachments not recommended by the manufacturer.

DIMENSIONS



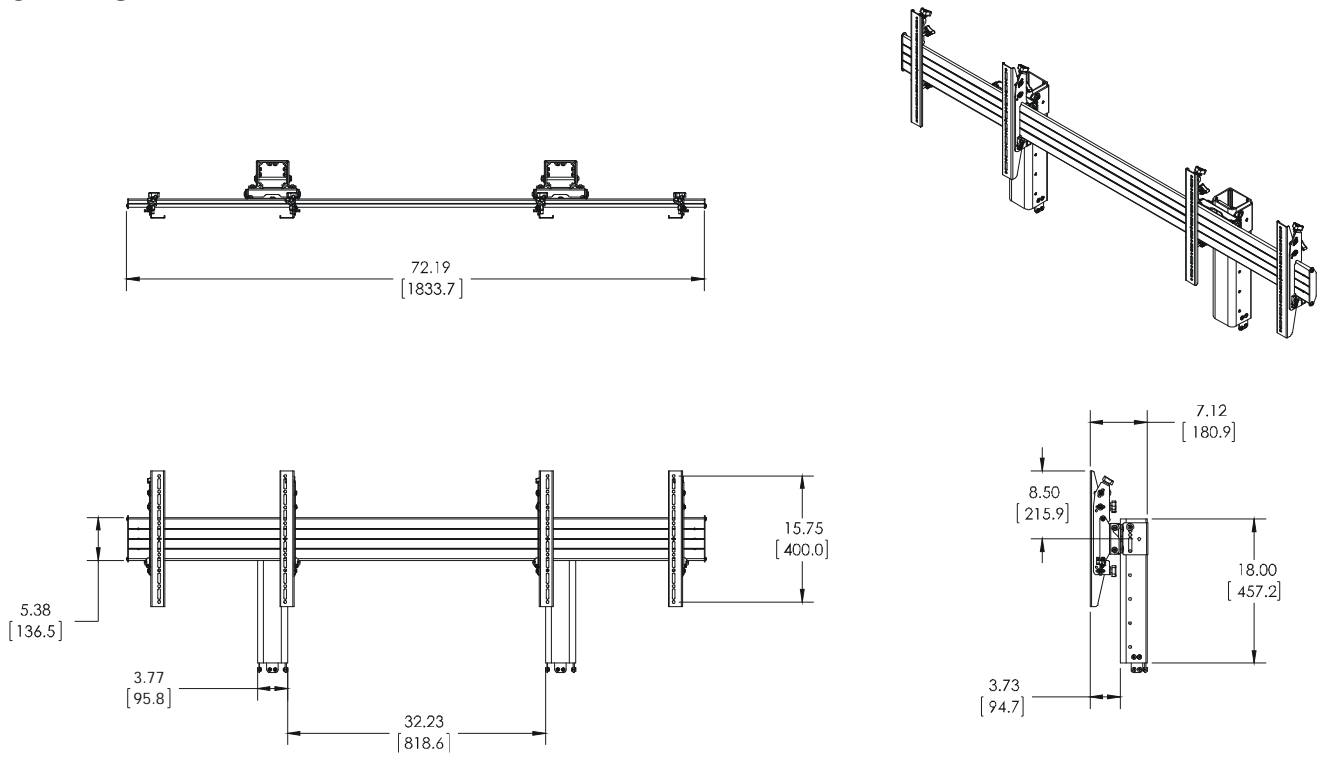



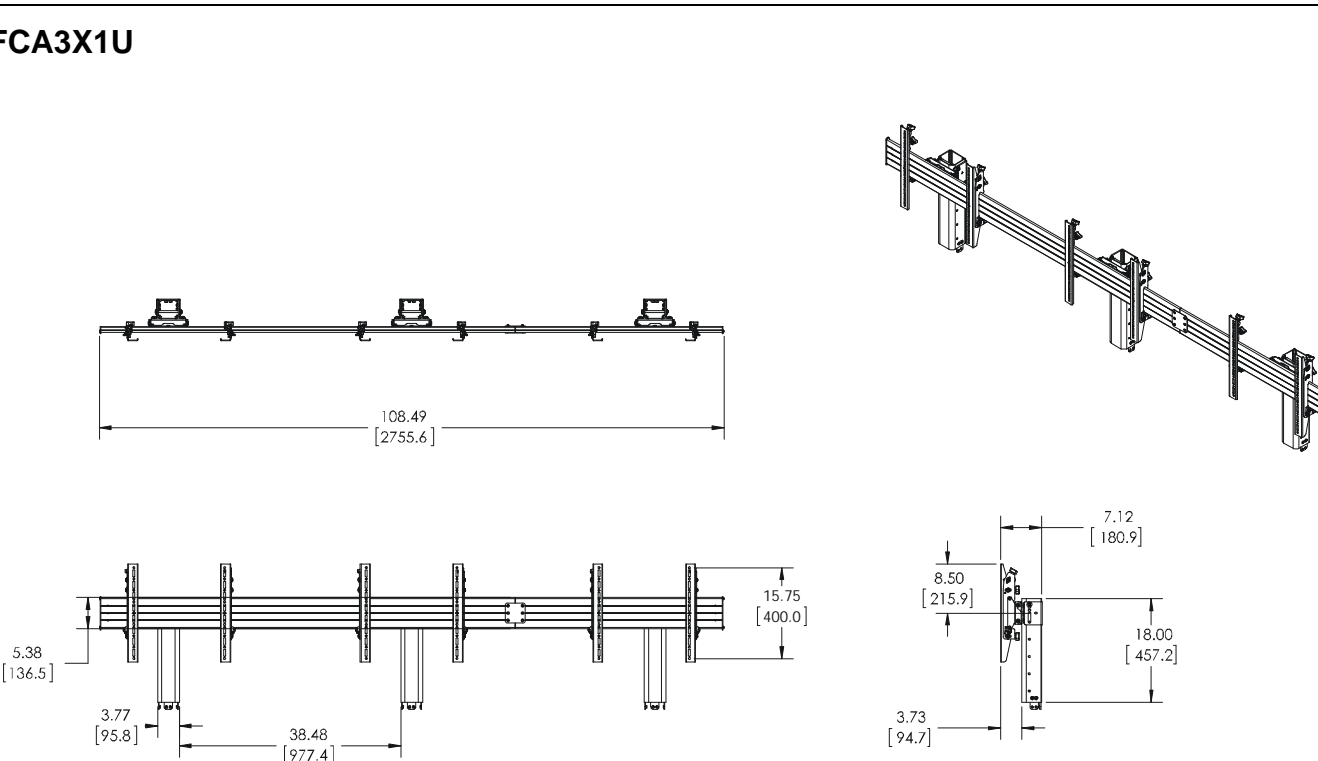



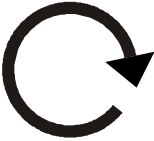

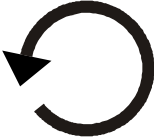
FCA2X1U



FCA3X1U



LEGEND

	<p>Tighten Fastener</p> <p>Apretar elemento de fijación</p> <p>Befestigungsteil festziehen</p> <p>Apertar fixador</p> <p>Serrare il fissaggio</p> <p>Bevestiging vastdraaien</p> <p>Serrez les fixations</p>		<p>Pencil Mark</p> <p>Marcar con lápiz</p> <p>Stiftmarkierung</p> <p>Marcar com lápis</p> <p>Segno a matita</p> <p>Potloodmerkteken</p> <p>Marquage au crayon</p>
	<p>Loosen Fastener</p> <p>Aflojar elemento de fijación</p> <p>Befestigungsteil lösen</p> <p>Desapertar fixador</p> <p>Allentare il fissaggio</p> <p>Bevestiging losdraaien</p> <p>Desserrez les fixations</p>		<p>Drill Hole</p> <p>Perforar</p> <p>Bohrloch</p> <p>Fazer furo</p> <p>Praticare un foro</p> <p>Gat boren</p> <p>Percez un trou</p>
	<p>Phillips Screwdriver</p> <p>Destornillador Phillips</p> <p>Kreuzschlitzschraubendreher</p> <p>Chave de fendas Phillips</p> <p>Cacciavite a stella</p> <p>Kruiskopschroevendraaier</p> <p>Tournevis à pointe cruciforme</p>		<p>Adjust</p> <p>Ajustar</p> <p>Einstellen</p> <p>Ajustar</p> <p>Regolare</p> <p>Afstellen</p> <p>Ajuster</p>
	<p>Open-Ended Wrench</p> <p>Llave de boca</p> <p>Gabelschlüssel</p> <p>Chave de bocas</p> <p>Chiave a punte aperte</p> <p>Steeksleutel</p> <p>Clé à fourche</p>		<p>Remove</p> <p>Quitar</p> <p>Entfernen</p> <p>Remover</p> <p>Rimuovere</p> <p>Verwijderen</p> <p>Retirez</p>
	<p>By Hand</p> <p>A mano</p> <p>Von Hand</p> <p>Com a mão</p> <p>A mano</p> <p>Met de hand</p> <p>À la main</p>		<p>Optional</p> <p>Opcional</p> <p>Optional</p> <p>Opcional</p> <p>Opzionale</p> <p>Optie</p> <p>En option</p>
	<p>Hex-Head Wrench</p> <p>Llave de cabeza hexagonal</p> <p>Sechskantschlüssel</p> <p>Chave de cabeça sextavada</p> <p>Chiave esagonale</p> <p>Zeskantsleutel</p> <p>Clé à tête hexagonale</p>		<p>Security Wrench</p> <p>Llave de seguridad</p> <p>Sicherheitsschlüssel</p> <p>Chave de segurança</p> <p>Chiave di sicurezza</p> <p>Veiligheidsleutel</p> <p>Clé de sécurité</p>

TOOLS REQUIRED FOR INSTALLATION

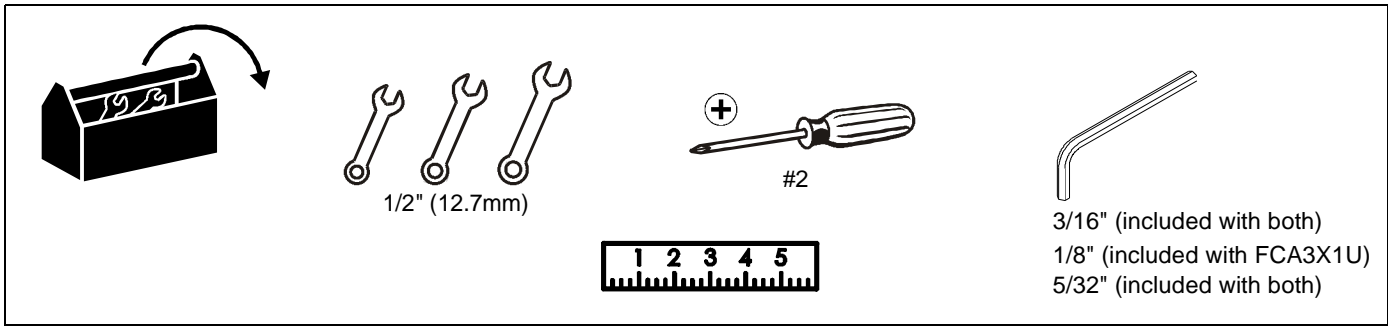

PARTS

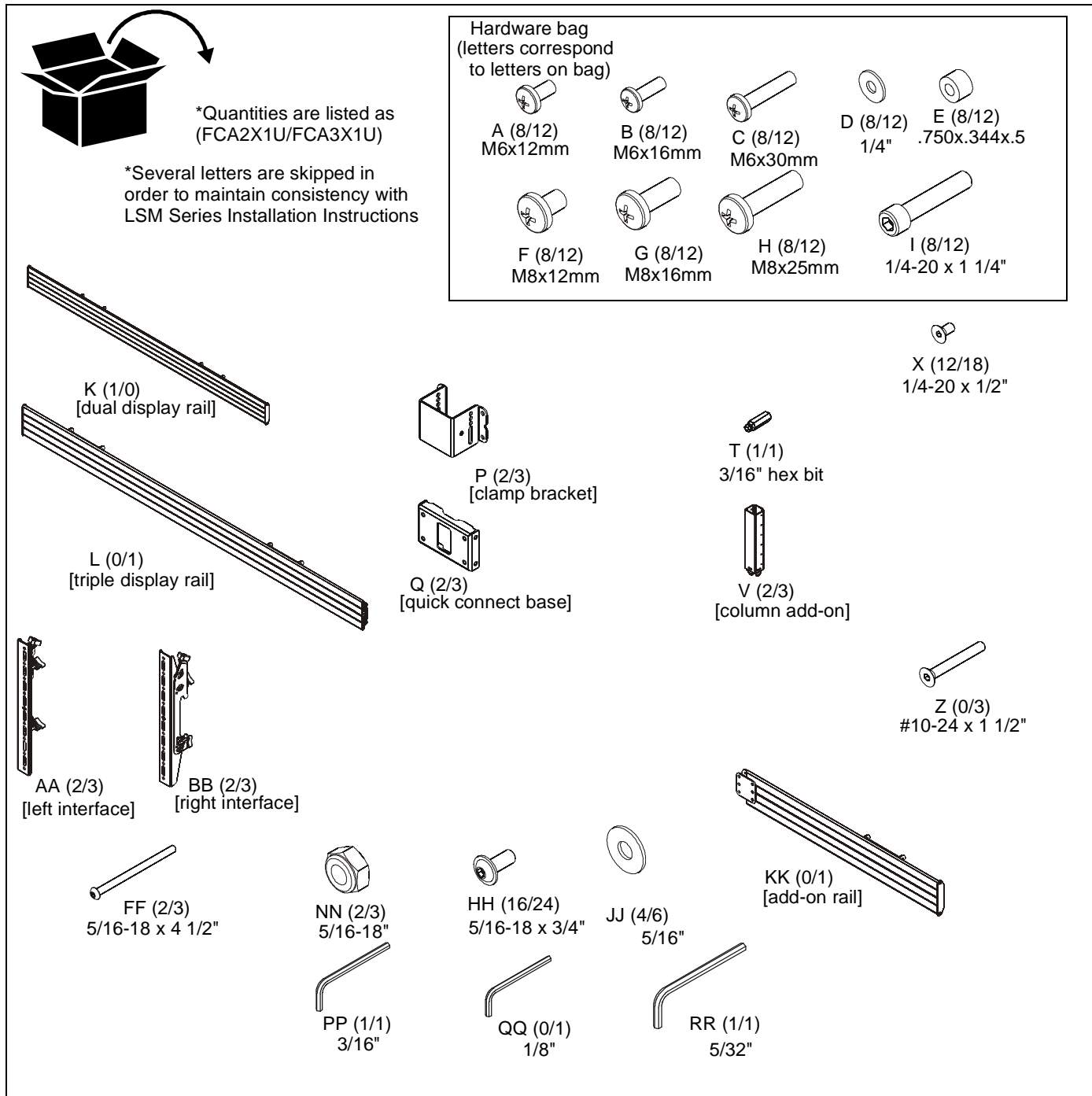

Assembly And Installation

The following installation instructions assume that the LVM Series cart has been assembled prior to the point of installing the rails to the columns. Refer to LVM Series installation instructions for details.

Column Add-On Installation

1. Insert one column add-on (V) to each column (M) making sure holes are lined up on each side. (See Figure 1)
2. Use six 1/4-20 x 1/2" flat head cap screws (X) to secure column each add-on (V) to each column (M). (See Figure 1)

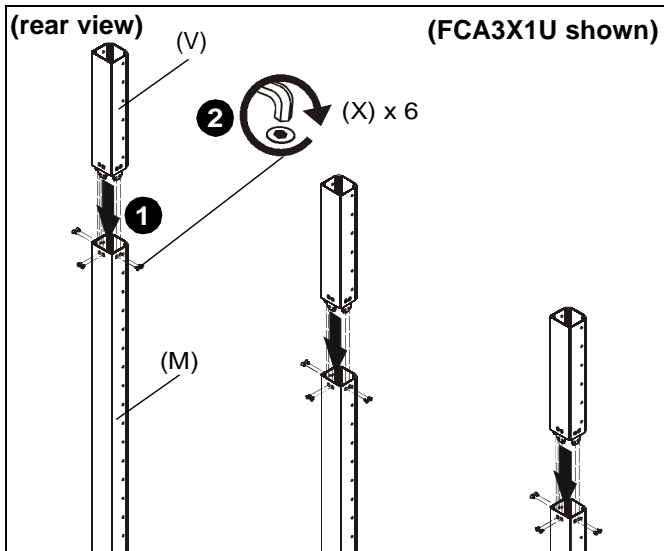

Figure 1

Rails Installation

1. Using display dimensions, determine where the center of the top displays will be on the cart.

IMPORTANT ! : Install all column add-ons (V), if applicable, prior to installing rails to columns.

2. Place clamp brackets (P) on column add-ons (V) in the position of where the center of the top displays will be on the cart with the diamond on the brackets being placed at the exact center location. (See Figure 2)

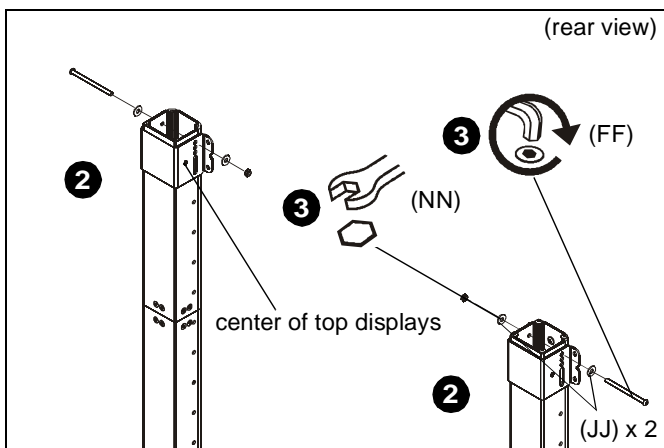

Figure 2

3. Use 5/16-18 x 4 1/2" button head cap screw (FF), two 5/16" washers (JJ) and 5/16-18" lock nut (NN) to secure each clamp bracket (P) to column. (See Figure 2)

NOTE: Clamp brackets (P) may be flipped in order to use long slots for installation if necessary. (See Figure 3)

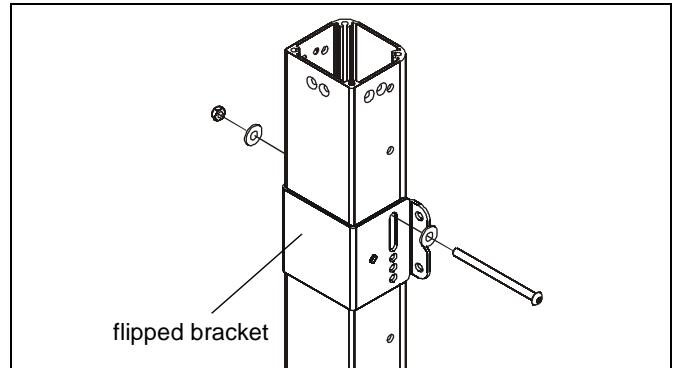

Figure 3

4. Measure one screen height down from center point on installed clamp brackets to determine mounting location of lower clamp brackets. (See Figure 4)
5. Use 5/16-18 x 4 1/2" button head cap screw (FF), two 5/16" washers (JJ) and 5/16-18" lock nut (NN) to install clamp brackets for lower displays with center diamond one screen height below center diamond of upper installed brackets. (See Figure 4)

NOTE: If some clearance is desired in between displays, install lower brackets slightly more than one screen height below upper brackets.

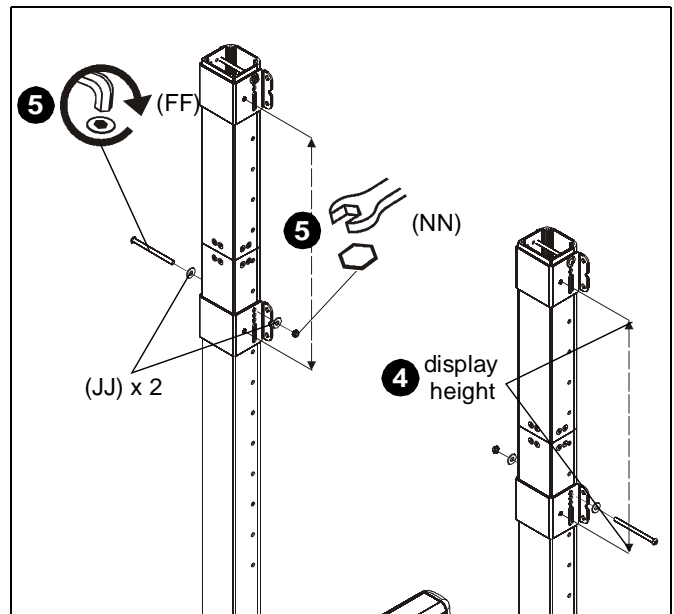

Figure 4

6. Use four 5/16-18 x 3/4" button head flange screws (HH) to secure each attached clamp bracket (P) to a quick connect base (Q). (See Figure 5)

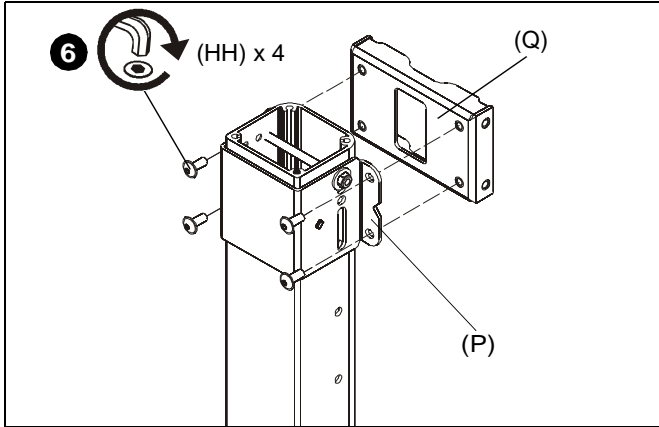

Figure 5

NOTE: If rails must be installed over cable management holes on column, cables must be routed prior to installing rails onto quick connect bases. See Cable Management section for details.

7. Install two 5/16-18 x 3/4" button head flange screws (HH) into the top holes on each quick connect base (Q). (See Figure 6)

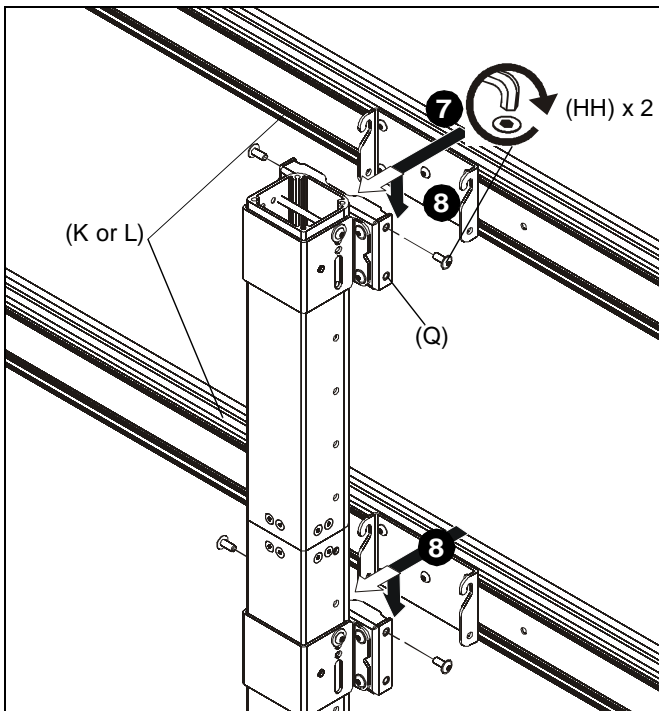

Figure 6

8. Hang rails (K or L) into screws installed in previous step to quick connect bases (Q). (See Figure 6)

IMPORTANT ! : If installing the triple display rail (L), install rail to left and center columns so that add-on rail can be installed to right column. See Add-On Rail Installation section for details.

9. Install two 5/16-18 x 3/4" button head flange screws (HH) into the lower holes on each quick connect base (Q) to secure rails to quick connect bases. (See Figure 7)
10. Tighten all 5/16-18 x 3/4" button head flange screws (HH).

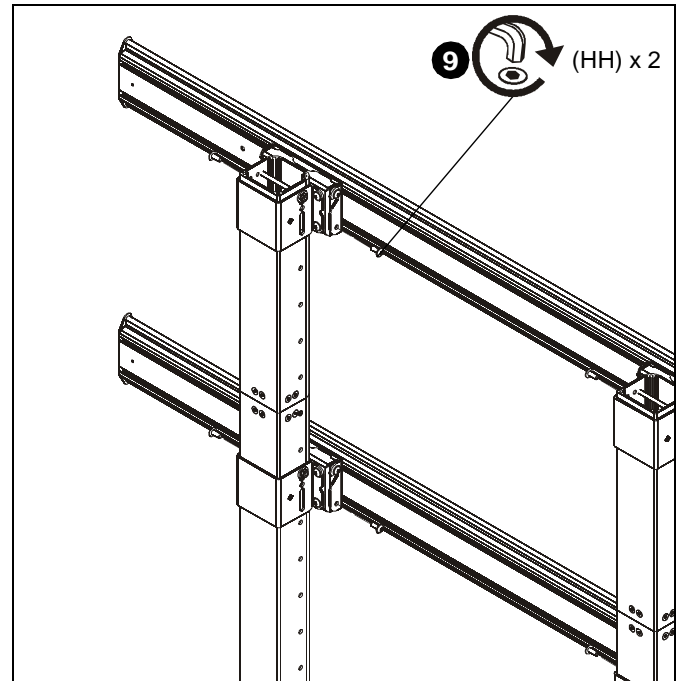

Figure 7

Add-On Rail Installation (FCA3X1 only)

1. Install add-on rail (KK) to right column following instructions in Rails Installation section.
2. Use three #10-24 x 1 1/2" flat head cap screws (Z) to attach add-on rail (KK) to display rail (L). (See Figure 8)

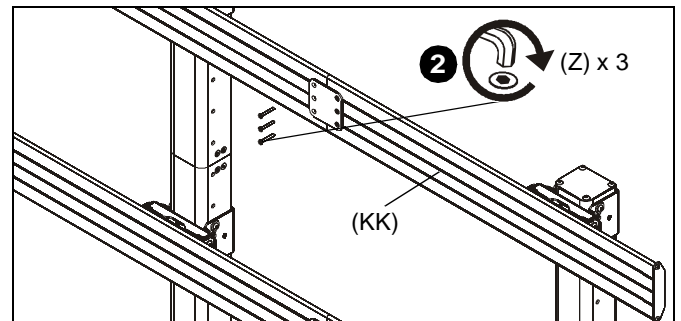

Figure 8

Complete installation of displays following LVM Series installation instructions.

IMPORTANT ! : Install displays to lower rails prior to installing displays to upper rails. See LVM Series installation instructions for further details regarding acceptable and safe mounting orders.



Our Mounts. **Your Vision.**

Chief Manufacturing, a products division
of Milestone AV Technologies

8800-002175 Rev00
©2012 Milestone AV Technologies, a
Duchossois Group Company
www.chiefmfg.com
05/12

USA/International	A 6436 City West Parkway, Eden Prairie, MN 55344 P 800.582.6480 / 952.225.6000 F 877.894.6918 / 952.894.6918
Europe	A Franklinstraat 14, 6003 DK Weert, Netherlands P +31 (0) 495 580 852 F +31 (0) 495 580 845
Asia Pacific	A Office No. 1 on 12/F, Shatin Galleria 18-24 Shan Mei Street Fotan, Shatin, Hong Kong P 852 2145 4099 F 852 2145 4477

