



## FEATURES

- 1 AUTODRIVE™ SYSTEM**  
Ultra fast and quiet travel at over 2" (51 mm) per second with preset viewing position.
- 2 TELESCOPING DESIGN**  
Collapses to a stored height of 31" (790 mm) with approximately 40" (101.6 cm) of travel.
- 3 MULTIPLE CONTROL OPTIONS**  
Control options include: serial communication, dry contact control, and IR remote (included).
- 4 Q-LATCH® MOUNTING SYSTEM**  
Flat panel secures to mount with a latching flag. Easy to connect/disconnect – no tools needed!
- 5 CABLE MANAGEMENT**  
Unique cable management system allows cables to move freely with the lift.



## SPECIFICATIONS

Extension	31-71" (79-180 cm)
Weight Capacity	190 lbs (86.2 kg)
Color	Black

## WHAT YOU NEED TO KNOW

**MULTIPLE CONTROL OPTIONS**  
AMX/Crestron control compatibility

**VOLTAGE OPTIONS**  
120V or 230V (for 230V order the CM2L40I)

**FLEXIBLE INSTALLATION**  
No width constraints

**SHIPS FULLY ASSEMBLED**

## TECHNICAL DRAWINGS

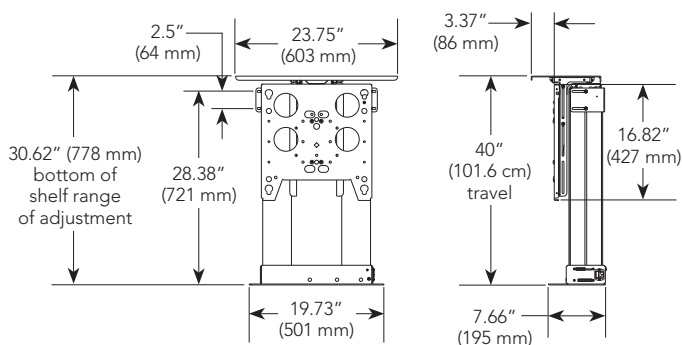

## RECOMMENDED ACCESSORIES



**PACLR1** ■ Side Speaker Adapter

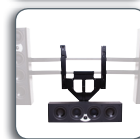

**PACCC1** ■ Center Channel Speaker Adapter

For a complete list of flat panel mount accessories see page 83.