



AUTOMATED MOUNTS CM2C40 □ 32 - 61" CEILING LIFT



FEATURES

- 1 AUTODRIVE™ SYSTEM**
Ultra fast and quiet travel at over 2" (51 mm) per second with preset viewing position.
- 2 TELESCOPING DESIGN**
Collapses to a stored height of 31" (790 mm) with approximately 40" (101.6 cm) of travel.
- 3 MULTIPLE CONTROL OPTIONS**
Control options include: serial communication, dry contact control, and IR remote (included).
- 4 Q-LATCH™ MOUNTING SYSTEM**
Flat panel secures to mount with a latching flag. Easy to connect/disconnect – no tools needed!
- 5 CABLE MANAGEMENT**
Unique cable management system allows cables to move freely with the lift.

WHAT YOU NEED TO KNOW

MULTIPLE CONTROL OPTIONS

AMX/Crestron control compatibility

VOLTAGE OPTIONS

120V or 230V (for 230V order the CM2C40I)

FLEXIBLE INSTALLATION

No width constraints

SHIPS FULLY ASSEMBLED

SPECIFICATIONS

Extension	31-71" (79-180 cm)
Weight Capacity	170 lbs (77.1 kg)
Color	Black

RECOMMENDED ACCESSORIES



PACLR1 ■ Side Speaker Adapter



PACCC1 ■ Center Channel Speaker Adapter

TECHNICAL DRAWINGS

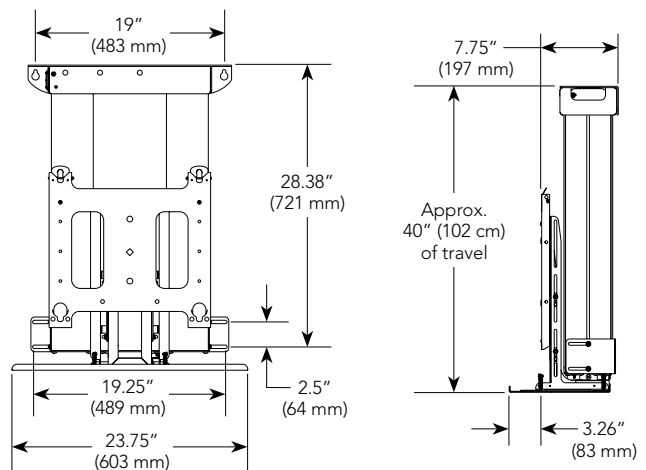

For a complete list of automated mount accessories see page 81.