

Assembly & Installation Instructions: Conform 14" Pole, C-Clamp & Grommet Base CONF-PB-14CCG-S

Parts Included

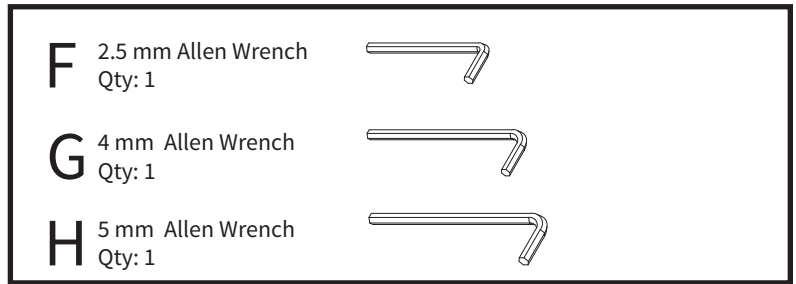
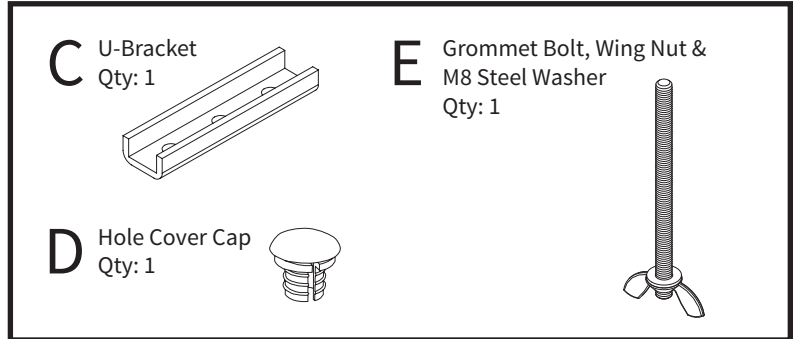
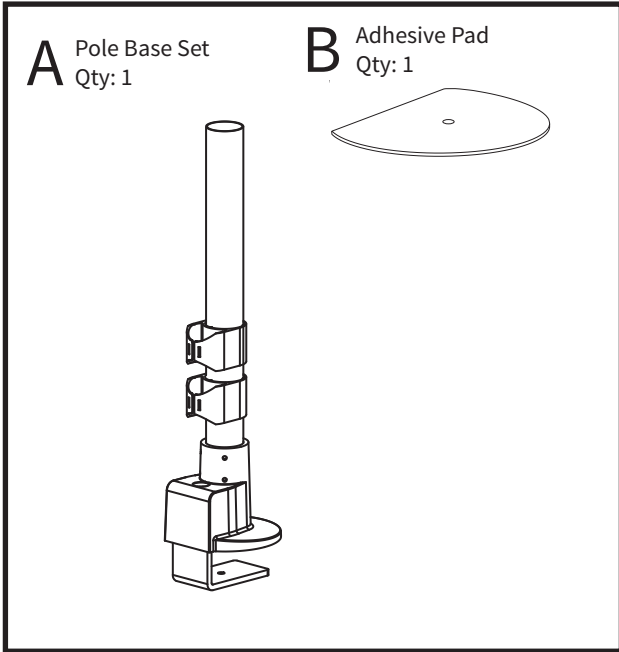

Required Parts Sold Separately

Conform Monitor Arm.

Tools Required

A Phillips head screwdriver and included Allen Wrenches.
If a grommet mount hole is required, you'll need a drill and .375" bit.

 **Do not use on hollow core tables.**
Do not exceed 48 lb.

1 C-Clamp Installation

- a** Using 5 mm Allen wrench (H), loosen the C-Clamp bolt on the Pole Base (A) wide enough to fit over the edge of the worksurface.
- b** Remove Adhesive Pad (B) backing. Apply the pad to the bottom surface of the base, adhesive side up, so that it aligns with the front edge of the base and sticks in place.
- c** Place C-Clamp over the rear edge of the worksurface.
- d** Tighten the clamp by turning the C-Clamp Bolt clockwise, using 5 mm Allen wrench (H) until secure.

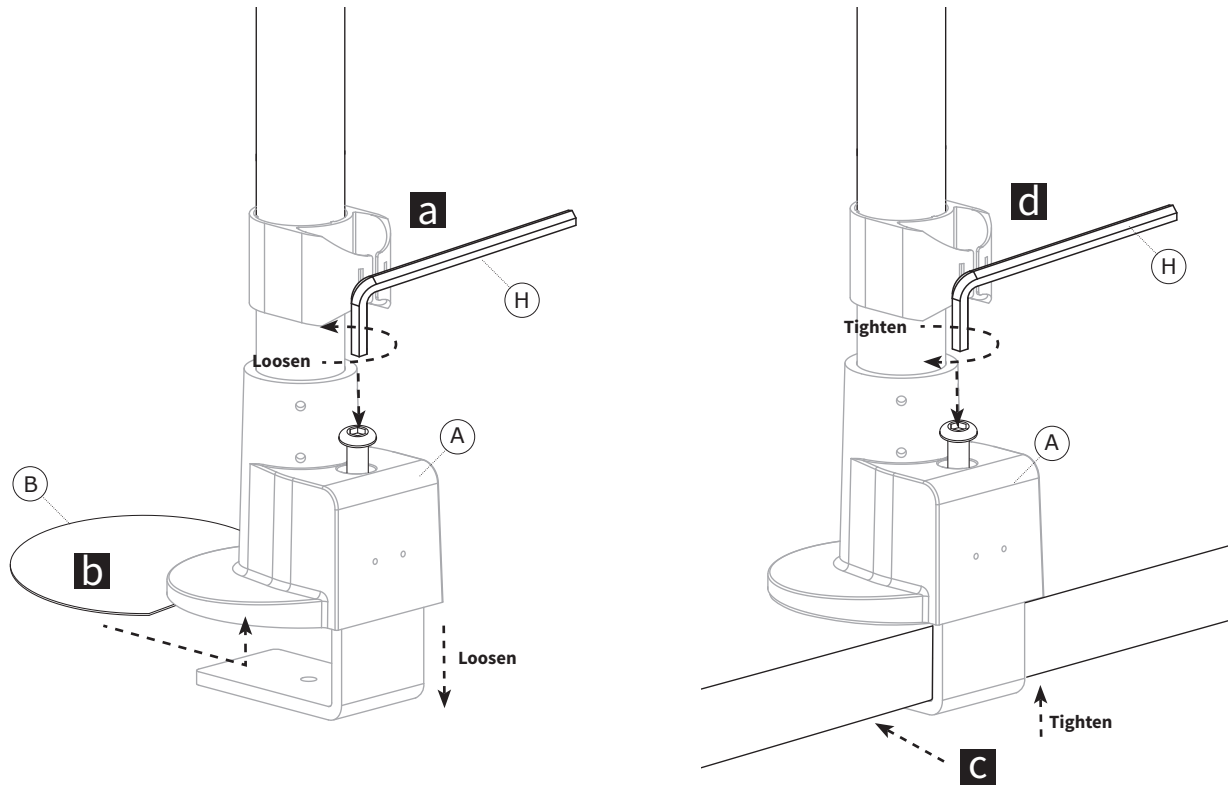

2 Grommet Mount Installation

Note: A grommet hole or small hole is required in your worksurface to install the grommet mount.

- a** Drill a .375" hole in worksurface if needed. The minimum distance from the edge of the worksurface to the center of the grommet hole is 2.125". The grommet mount can accommodate existing holes up to 3" in diameter.
- b** Using 5 mm Allen wrench (H), loosen the C-Clamp bolt on the Pole Base (A) to remove C-Clamp from the Base. Also remove the C-Clamp bolt.
- c** Remove the Adhesive Pad's pre-punched hole and remove the adhesive backing. Apply the adhesive side to the bottom of the Desk Base, aligned with the front edge of Base, and stick in place.
- d** Insert Grommet Bolt (E) through the adhesive pad's hole and into the Pole Base (A). Tighten with 4 mm Allen Wrench (G).
- e** Insert the installed Pole Base Bolt (E) through the grommet hole of worksurface. Make sure the mount does not overlap the edge of the worksurface.
- f** From under the worksurface, place the U-Bracket (C) onto the Grommet Bolt (E) then place the M8 Steel Washer (E) followed by the Wing Nut (E) onto the Bolt and tighten Wing Nut to secure the base to the desktop.
- g** Insert Hole Cover Cap (D) to cover the C-Clamp bolt hole.

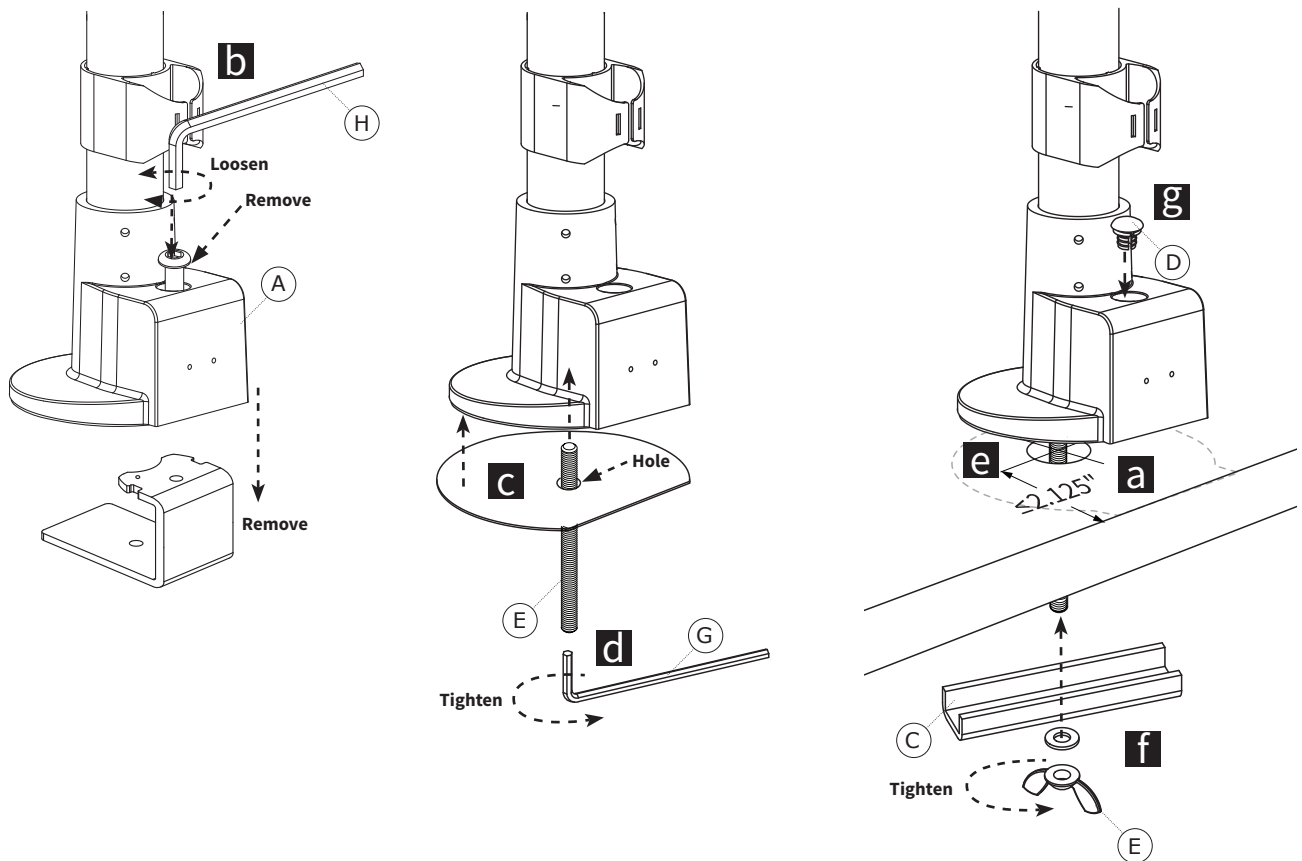

3 Ready for Arm Installation

You are now ready to attach your selected Conform Monitor Arm (sold separately).

