

ERGOTRON®

Zido Phlebotomy Cart Package

Part Number	BZD04CG/CG4
Product Includes	Wood lipped shelf with bracket, 17" (43.18 cm) wide handle, deep drawer, glove box holder, metal bin, 2.5" (6.35 cm) diameter adjustable-height column with holes in 1" (2.54 cm) increments for accessory installation, rubber column cover, heavy metal base, and 4 casters (4" [10.16 cm] size, 2 locking)
Materials and Finishes	Glove box, bin, steel column and cast metal base receive a baked-on powder coated finish that's durable and easy to clean. Shelf is 1" (2.54 cm)-thick medium density fiberboard wrapped in Comfort Edge thermoplastic laminate that resists cracking and chipping and stands up to a wide range of chemicals
Column Height Range	
Lift Capacity	16-30 lbs. (7.26 - 13.61 kg)
Weight Capacity	50 lbs. (22.68 kg) on the shelf; 150 lbs. (68.04 kg) overall
Base Dims	17" W x 22.25" D (43.18 x 56.52 cm)
Shelf Dims	22" W x 17" D (55.88 x 43.18 cm)
Mobility	Easy to move with 4" (10.16 cm) twin-wheel rubber casters (two locking). Heavy cast metal base provides stability
Warranty	Lifetime against manufacturing defects on materials and workmanship. 5 years on gas cylinder

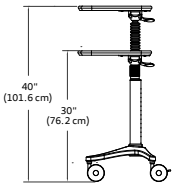

Squeeze the lever and the gas cylinder helps you lift the shelf as high as 40" (101.6 cm) or lower it as low as 30" (76.2 cm) to a comfortable height, perfect whether you are sitting or standing. Release the lever and the shelf stays in place

Height-Adjustable Phlebotomy Cart — Carry all your phlebotomy supplies on a compact, easy-to-steer cart that takes everything you need right to your patient. Easily adjust the cart height 30"–40" (76.2 - 101.6 cm) so it's comfortable for clinician and patient. Use the built-in storage for gloves, sharps containers, and more.

- ① **Handle** — The 17" (43.18 cm) wide handle makes the cart easy to steer
- ② **Adjustable Height** — Set the shelf height 30" - 40" (76.2 - 101.6 cm) so it's comfortable for patients and clinicians
- ③ **Storage for Gloves and Sharps** — This cart has a place for everything, including a glove box holder and a metal bin with 3" (7.62 cm)-high sides to hold your sharps
- ④ **Contoured Top** — A 1/2" (1.27 cm)-high lip runs all the way around the cap shelf to keep vials and supplies in place
- ⑤ **Locking Drawer** — The 5-3/4" (14.61 cm)- high drawer features a keyed lock. It's big enough to store vials and paperwork for security and privacy
- ⑥ **Large Casters** — The 4" (10.16 cm) diameter twin-wheel casters (2 locking) travel easily over thresholds and directly to the point of care



The 30-year legacy of Anthro Corporation lives on in its world-class factory, flexible award-winning designs, and market-leading personal customer service. When you see Anthro-DNA, it signifies quality manufacturing and technology leadership.

© 2016 Ergotron, Inc. rev. 04/07/2016 Literature made in the U.S.A.
Content is subject to change without notification

Americas Sales and Corporate Headquarters

St. Paul, MN USA
 (800) 888-8458
 +1-651-681-7600
 www.ergotron.com
 sales@ergotron.com

EMEA Sales

Amersfoort, The Netherlands
 +31 33 45 45 600
 www.ergotron.com
 info.eu@ergotron.com

APAC Sales

Tokyo, Japan
 www.ergotron.com
 apaccustomerservice@ergotron.com

Worldwide OEM Sales

www.ergotron.com
 info.oem@ergotron.com

