

Ergotron® LX

Dimensional & Range of Motion Illustrations

Wall Mount LCD Arm

Dimensions

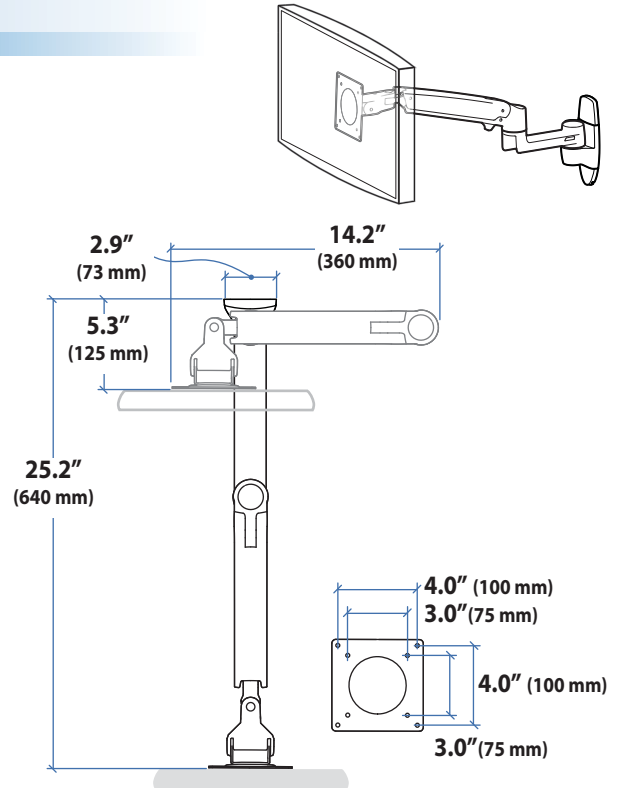
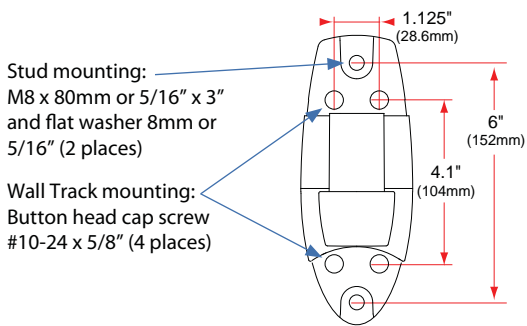
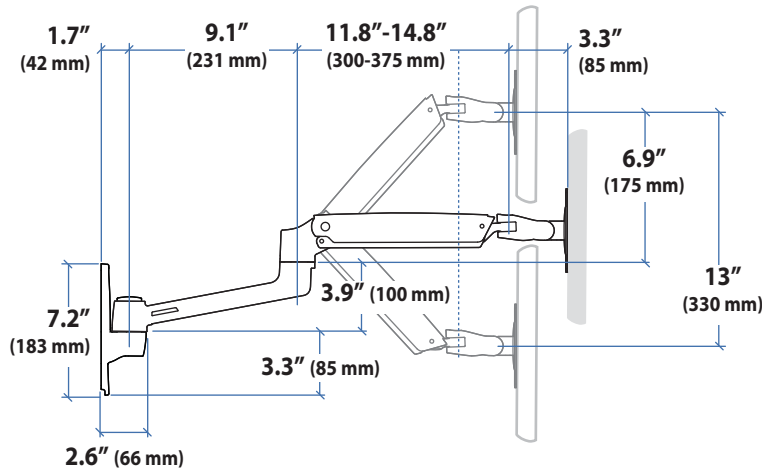

Range of Motion

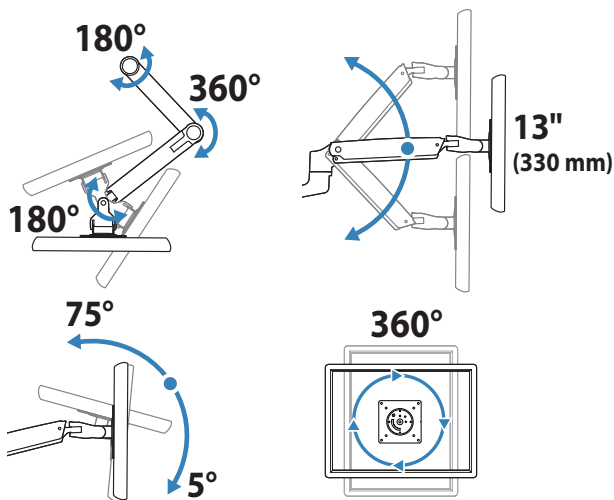

Weight Capacity

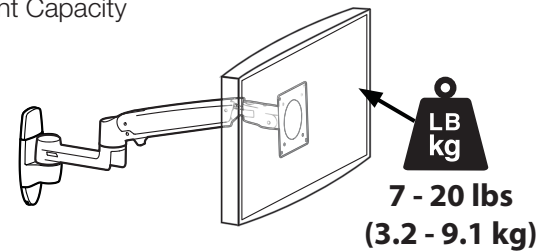

Monitor depth greater than 2.5" (64 mm) may diminish capacity.
Call Ergotron for more information.

© 2009 Ergotron, Inc. rev. 10/20/2009 DIM-LXWM Content is subject to change without notification

**Americas Sales and
Corporate Headquarters**
St. Paul, MN USA
(800) 888-8458
+1-651-681-7600
www.ergotron.com
sales@ergotron.com

EMEA Sales
Amersfoort, The Netherlands
+31 33 45 45 600
www.ergotron.com
info.eu@ergotron.com

APAC Sale
Tokyo, Japan
www.ergotron.com
apaccustomerservice@ergotron.com

Worldwide OEM Sales
www.ergotron.com
info.oem@ergotron.com

