

TECHNICAL DATA SHEET - Extension Column Stabilizer



MODEL: ACC 050

Features:

- Helps stabilize column to reduce swaying
- Reduces unwanted movement of equipment
- Scratch-resistant black fused epoxy finish

Dimensions:

For product dimensions, see page 2.

Components:

- Two column supports
- Hose Clamp
- Wood joist mounting hardware

The ACC 050, Extension Column Stabilizer, can be used to reduce unwanted swaying for installations involving extension columns. Two supports are provided to attach to any standard peerless 1.9" OD extension column.

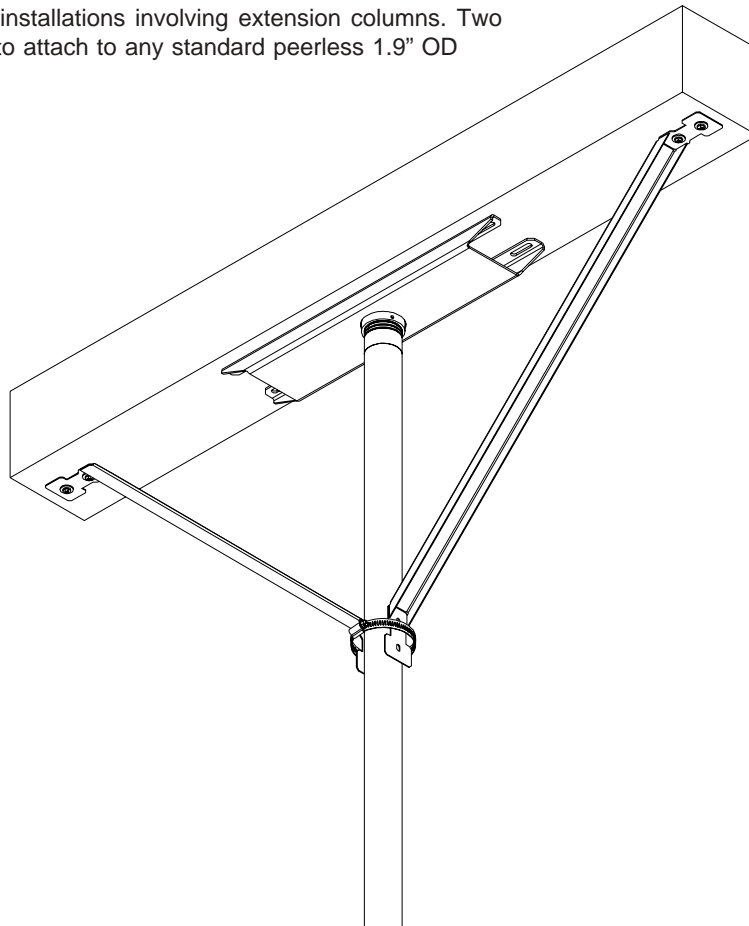

ARCHITECTS SPECIFICATIONS:

The Extension Column Stabilizer shall be a Peerless model ACC 050 and shall be mounted where indicated on the plans. It shall consist of a two column supports, a hose clamp and wood joist mounting hardware. It shall be constructed primarily of 16 gage cold rolled steel and finished in black fused epoxy. Assembly and installation shall be done according to the instructions provided by the manufacturer.

TECHNICAL DATA SHEET

MODEL: ACC 050

Dimensions:**Weight:**

2.04 lbs. (.93 kg.)

Shipping weight:

2.84 lbs. (1.3 kg.)

Maximum Load Capacity :

N/A

Shipping Carton dimensions:

L= 36 in (914 mm)

W= 4 in (102 mm)

H= 4 in (102 mm)

