

ACC-V800X

Accessory Adapter Rails

For VESA® 600 x 400 and 800 x 400mm mounting patterns

Increase your mounts' compatibility with the ACC-V800X by Peerless -AV. This low cost adapter rail solution for displays with VESA® 600 x 400 or 800 x 400mm mounting patterns allows the display to be mounted in either landscape or portrait orientation by attaching to the mount at the 400 x 400mm pattern.

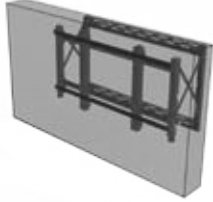

TV size: 40"-65"



Max load: 130lb (59kg)

FEATURES

- Adapter rail solution for displays with 600 x 400 and 800 x 400mm mounting patterns
- Attaches to the mounts with 400 x 400mm mounting patterns
- Allows the display to be mounted in portrait or landscape
- Mount attaching hardware recesses into the rail to prevent scratching of the display
- Security hardware deters tampering and theft

■ **MOUNT COMPATIBILITY**
Attaches to the mount at the 400mm wide mounting pattern



■ **DISPLAY COMPATIBILITY**
Attaches to the display at the 600mm wide or 800mm wide pattern



Shown with DS-VW765-LAND mount (sold separately)



MADE IN USA

CLICK: www.peerless-av.com

CALL: 800.865.2112

FAX: 800.359.6500

peerless-AV™

ACC-V800X Accessory Adapter Rails for VESA® 600 x 400 and 800 x 400mm mounting patterns

Product Specifications

	DIMENSIONS (W x H x D)	PRODUCT WEIGHT	LOAD CAPACITY	FINISH	AVAILABLE COLORS
ACC-V800X	35.50" x 0.50" x 1.00" (902 x 13 x 25mm)	3.2lb (1.4kg)	130lb (59kg)* <small>* Be careful not to exceed the max load of the mount</small>	Powder Coat	Black

Package Specifications

	PACKAGE SIZE (L x W x H)	PACKAGE SHIP WEIGHT	PACKAGE UPC CODE	PACKAGE CONTENTS	UNITS IN PACKAGE
ACC-V800X	37.375" x 6.25" x 2.187" (949 x 159 x 56mm)	4.2lb (1.9kg)	735029282112	Adapter rails and mounting hardware	1

All dimensions = inch (mm)

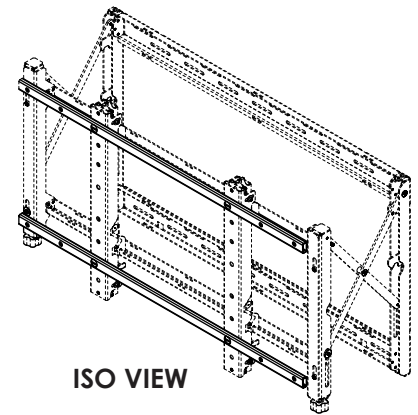
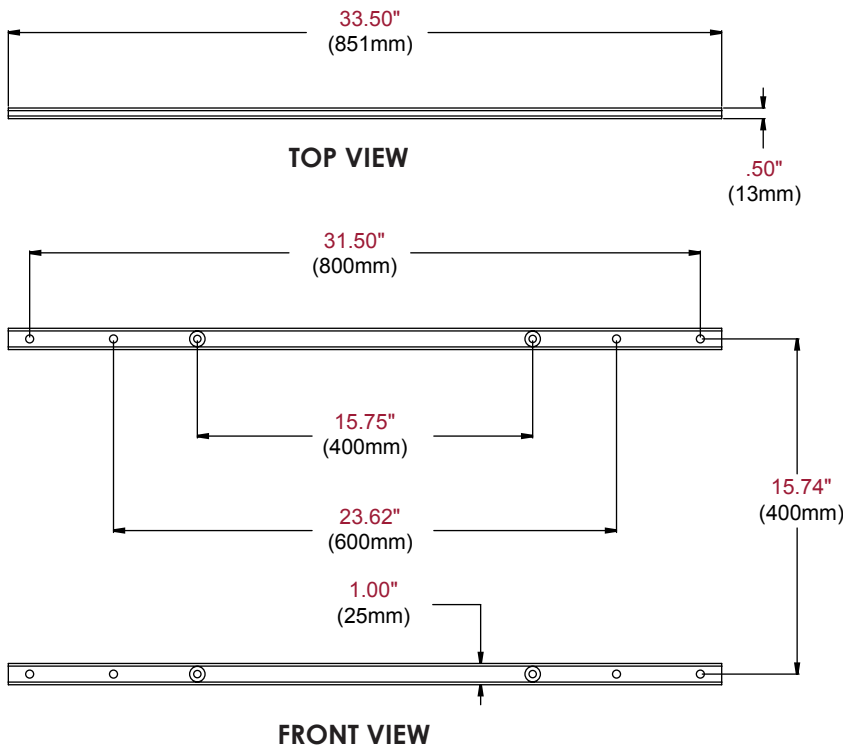

ARCHITECTS SPECIFICATIONS

The Accessory Adapter Rails shall be a Peerless-AV model ACC-800X and shall be located where indicated on the plans. It shall be constructed of heavy gauge cold rolled steel and aluminum and finished with scratch resistant Black Fused Epoxy. Assembly and installation shall be done according to instructions provided by the manufacturer.