

# TECHNICAL DATA SHEET - Armor Lock Plus™ Security Cable with Keylock



Model: ACC 020

The **Armor Lock Plus** security cable with Keylock features a multi-strand steel cable with black vinyl sheath providing an extra level of security for projector installations.

### Features:

- Ships complete with 3/16" diameter cable, a Keylock, security screws, security allen wrench, and an attachment plate for easy connection to the mount and projector.
- Two keys are supplied for convenience
- For use with any projector that has the security slot built in the chassis
- Provides an extra level of security beyond the Armor Lock™ security already built into the projector mount.

### Dimensions:

Shipping Weight: .98 lb (0.44 kg)

For product dimensions, see page 2.

### Shown with Vector Pro™/Vector Pro Plus™ mounts

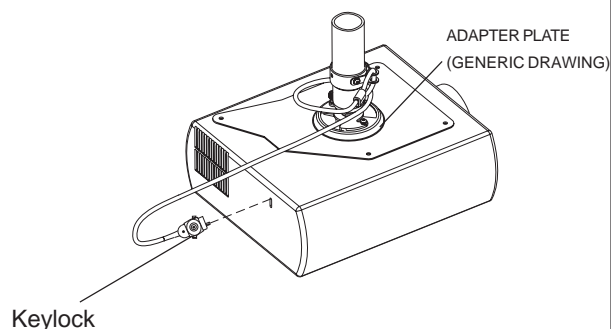

### Shown with PRS Series Mount

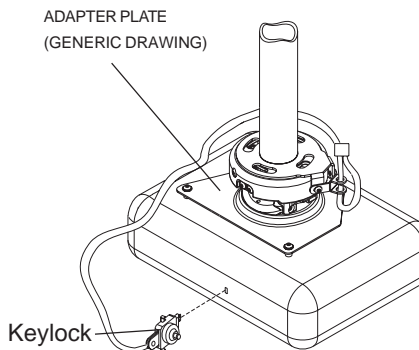

### Shown with Encore Mount

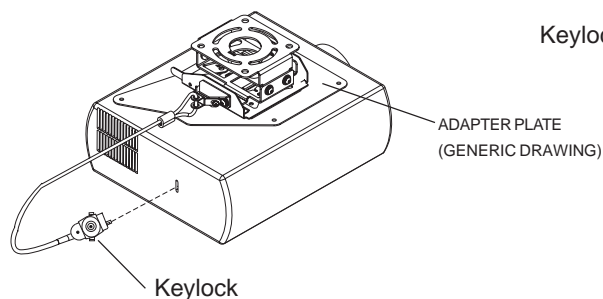

### ARCHITECTS SPECIFICATIONS:

The Armor Lock Plus security cable with Keylock shall be a Peerless model ACC 020. It shall be constructed of multi-strand steel cable with black vinyl sheath. It shall feature security screws. Installation and assembly shall be done in accordance with the instructions provided by the manufacturer.

**Peerless Industries, Inc.**  
 3215 W. North Ave. Melrose Park, IL 60160  
 708-865-8870 800-865-2112 Fax 708-865-2941  
[www.peerlessindustries.com](http://www.peerlessindustries.com)

ISSUED: 07-12-02 SHEET NO: 055-9603-6 04-03-07

©2007 Peerless Industries, Inc. All rights reserved.  
 Peerless is a registered trademark of Peerless Industries, Inc.  
 Armor Lock, Armor Lock Plus, Vector Pro and Encore are trademarks of Peerless Industries, Inc.  
 All other brand and product names are trademarks or registered trademarks of their respective owners.

# TECHNICAL DATA SHEET

**Model: ACC 020**

ALL DIMENSION =  $\frac{\text{INCH}}{\text{(MM)}}$

