

Parts List

Before you start make sure all parts listed are included with your product.

Description	Qty.	PLP-V100	PLP-V100S
AA adapter bracket - top plate	1	200-1289	200-4289
BB adapter bracket - bottom plate	1	200-1599	200-4599
CC M4 x 10 mm socket pin serrated washer head screw	4	510-1060	510-2060
DD M6 x 10 mm socket pin screw	4	520-1066	520-2066
EE 4 mm security allen wrench	1	560-9646	560-9646

Note: Actual parts may appear slightly different than illustrated.

IMPORTANT! Read entire instruction sheet before you start installation and assembly.

- Use four M4 x 10 mm socket pin serrated screws (CC) to attach bottom plate (BB) to monitor using security allen wrench (EE). Use four center holes of plate as shown below.

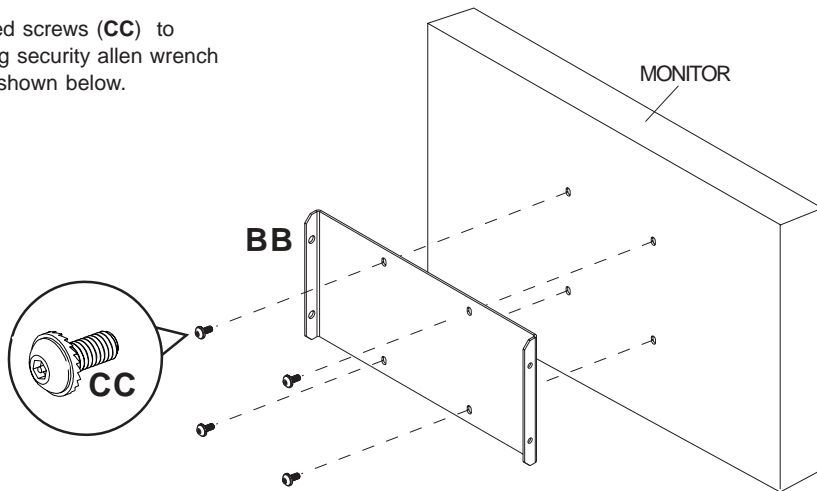

- Use four M6 x 10 mm socket pin screws (DD) to attach top plate (AA) to bottom plate (BB) using security allen wrench (EE).
NOTE: Top plate (AA) will have one set of threaded holes on one side and a set of non-threaded holes on the other side. Bottom plate (BB) will also have one set of threaded holes on one side and a set of non-threaded holes on the other side. All four M6 x 10 mm socket pin screws should pass through non-threaded holes first and into threaded holes.

