

INSTRUCTION MANUAL

Plasma Center Channel Speaker Shelf (PAC-302)

The Plasma Center Channel Speaker Shelf (PAC-302) can be used with the PAC-300 Side Speaker Adapter for a complete speaker installation with Chief mounts or attached separately to hold a single center channel speaker. The PAC-302 fits Chief's patented Q-Latch mounting system for easy installation and provides width and height adjustment for different size speakers.

The PAC-302 has five inches of height adjustment and adds ten pounds to the installation. The shelf is designed for below display installation only and the combined weight of the shelf, speakers and display must not exceed the weight capacity of the mount.

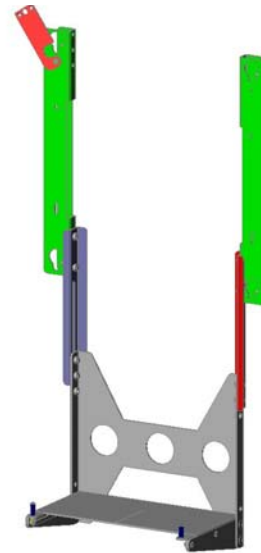

BEFORE YOU BEGIN

- **CAUTION:** To prevent damage to the PAC-302, which could affect or void the Factory warranty, thoroughly study all instructions and illustrations before you begin to install or operate the unit. Pay particular attention to the "Important Precautions" on Page 1.
- The maximum weight to be installed on the PAC-302 is limited by the weight specification of the mount.
- If you have any questions about this assembly, contact Chief Manufacturing at 1-800-582-6480.



IMPORTANT WARNINGS and CAUTIONS!

- WARNING:** A **WARNING** alerts you to the possibility of serious injury or death if you do not follow the instructions.
- CAUTION:** A **CAUTION** alerts you to the possibility of damage or destruction of equipment if you do not follow the corresponding instructions.
- **WARNING:** The maximum weight to be installed on the PAC-302 is limited to the weight specification of your mount.
 - **CAUTION:** Inspect the unit for shipping damage.

TOOLS REQUIRED FOR INSTALLATION

- Phillips screwdriver
- 3/8" and 7/16" wrench
- Socket set with extension
- Allen wrench set

NOTE: Other tools may be required depending on the method of installation.

CONTENTS

INSPECT PARTS BEFORE ASSEMBLY	2
Inspect The Mount	2
ASSEMBLE MOUNT	4

INSPECT PARTS BEFORE ASSEMBLY

Inspect The Mount

1. Carefully inspect the mount for shipping damage. If any damage is apparent, call your carrier claims agent and do not continue with the assembly procedure until the carrier has reviewed the damage.

NOTE: Read all assembly instructions before starting assembly.

2. Carefully inspect the Plasma Center Channel Speaker Shelf (PAC-302) components for damage (See Figure 1).

Item

- 10. Mounting Mount Button Support (Left)
- 20. Mounting Mount Button Support (Right)
- 30. Upright (Left)
- 40. Upright (Right)
- 50. Height Adjustment Assembly
- 60. Shelf
- 70. Shelf Support (Left)
- 80. Shelf Support (Right)
- 90. Nylock Lock Nut, Short, 10-24 (Qty. 5)

Item

- 100. Vinyl Cap, Black (Qty. 2)
- 110. Latching Flag
- 120. Phillips Undercut Machine Screw 10-24 X 1/2"
- 130. Nylon Spacer
- 140. 1/8" Hex Key
- 150. Mounting Button (Qty. 4)
- 160. Button Head Cap Screw 1/4-20X1/2" (Qty. 12)
- 170. Button Head Cap Screw 10-24X7/8" (Qty. 4)
- 180. Nylock Lock Nut 1/4-20 (Qty. 4)

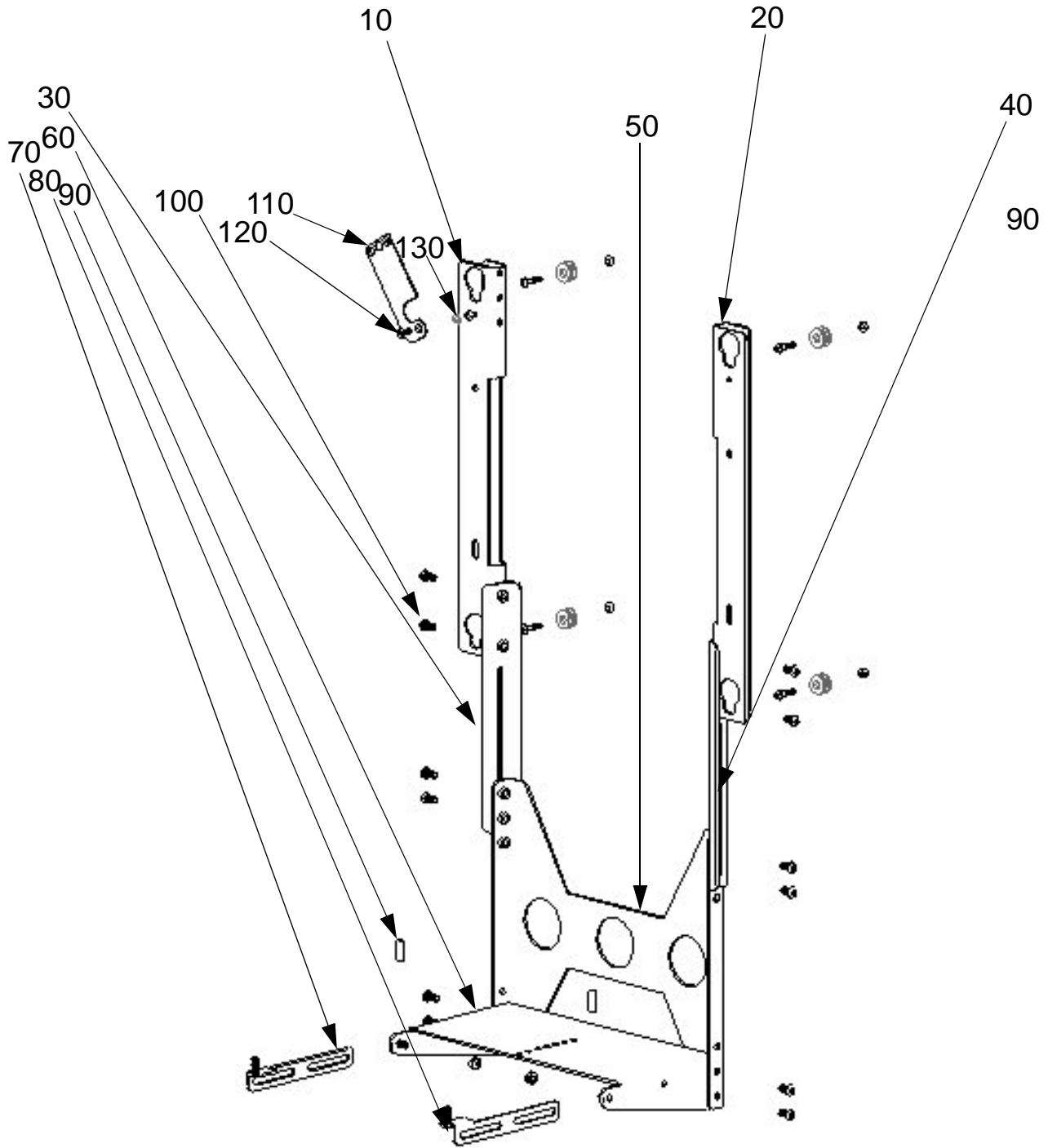

Figure 1. Plasma Center Channel Speaker Shelf

ASSEMBLE MOUNT

NOTE: Numbers in () refer to parts shown in Figure 1.

Assemble mount as follows:

1. Attach two mounting buttons (150) to left speaker mount button support (10) and right speaker mount button support (20) using four 10-24X7/8" button head cap screws (170) and four Nylock nuts (170) (see Figure 1, Figure 2, and Figure 3).
2. Install the latching flag (110) using the 10-24X1/2" Phillips undercut screw (120), Nylon spacer (130) and 10-24 Nylock nut (90) (see Figure 4).
3. Install left upright (30) on left speaker mount button support (10) using two 1/4-20X1/2" button head cap screws (160) (see Figure 5).
4. Install right upright (40) on right speaker mount button support (20) using two 1/4-20X1/2" button head cap screws (160) (see Figure 5).
5. Install height adjustment assembly (50) on left upright (30), with left speaker mount button support attached, using two 1/4-20X1/2" button head cap screws (160) (see Figure 5).
6. Install height adjustment assembly (50) on right upright (40), with left speaker mount button support attached, using two 1/4-20X1/2" button head cap screws (160) (see Figure 5).

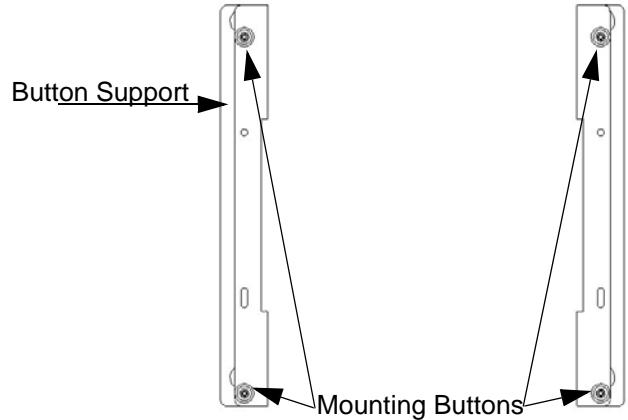

Figure 2. Mounting Button Location

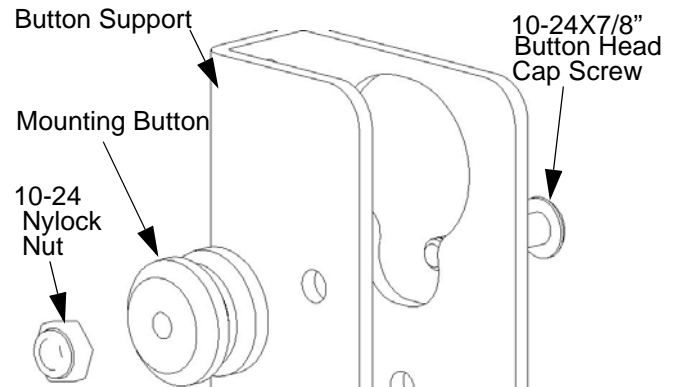

Figure 3. Mounting Button Attachment

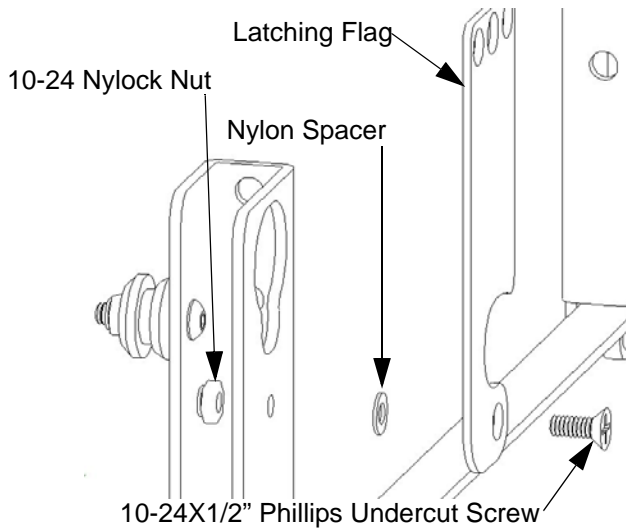

Figure 4. Install Latching Flag

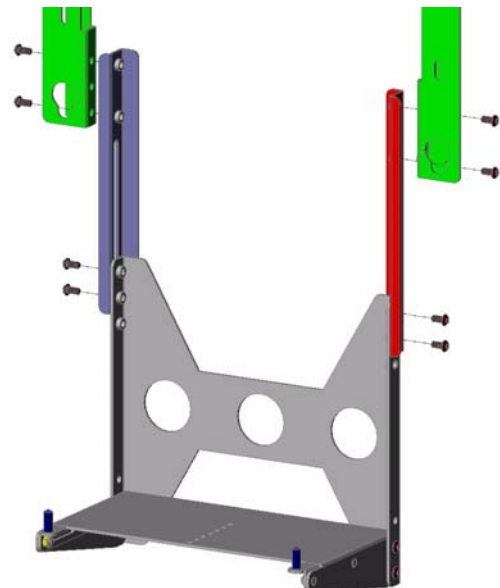

Figure 5. Install Uprights

8. Install black Vinyl caps (100) on left shelf support (30) and right shelf support (40) (see Figure 6).
9. Install left shelf support (30) on shelf (60) and secure using two 1/4-20 Nylock nuts (180) (see Figure 6).
10. Install right shelf support (40) on shelf (60) and secure using two 1/4-20 Nylock nuts (180) (see Figure 6).
11. Install shelf (60) between height adjustment assemblies and secure using four 1/4-20X1/2" button head cap screws (160) (see Figure 6).

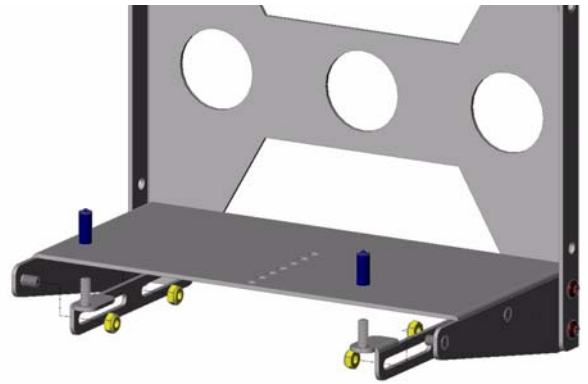

Figure 6. Install Shelf Components

