

# WPS4 Presentation Stations

## 39½" H x 18¼" W x 34½" D



Shown with electrical assembly

This mobile presentation cart has four gray laminate work surfaces with a black steel frame. The adjustable second shelf can be set from 31½" up to 39½" high.

Locking wood laminate cabinet model inner dimensions are: 18¾" H x 13¾" W x 13¾" D.

Optional 3-Outlet UL approved electrical assembly with 15 ft. cord.

A set of silent roll, 3" furniture casters, two with locking brakes.

**WPS4E**

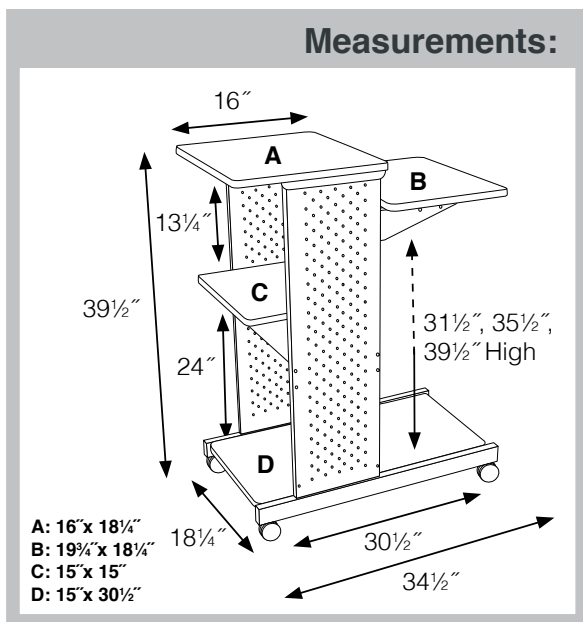

Shown with electrical assembly

**WPS4CE**