

8 7 6 5 4 3 2 1

THE INFORMATION CONTAINED IN THIS DRAWING IS THE SOLE PROPERTY OF PREMIER MOUNT DIVISION OF PMP. ANY REPRODUCTION IN PART OR WHOLE WITHOUT THE WRITTEN PERMISSION OF PREMIER MOUNT DIVISION OF PMP IS PROHIBITED.

REVISIONS			
REV.	DESCRIPTION	DATE	APPROVED

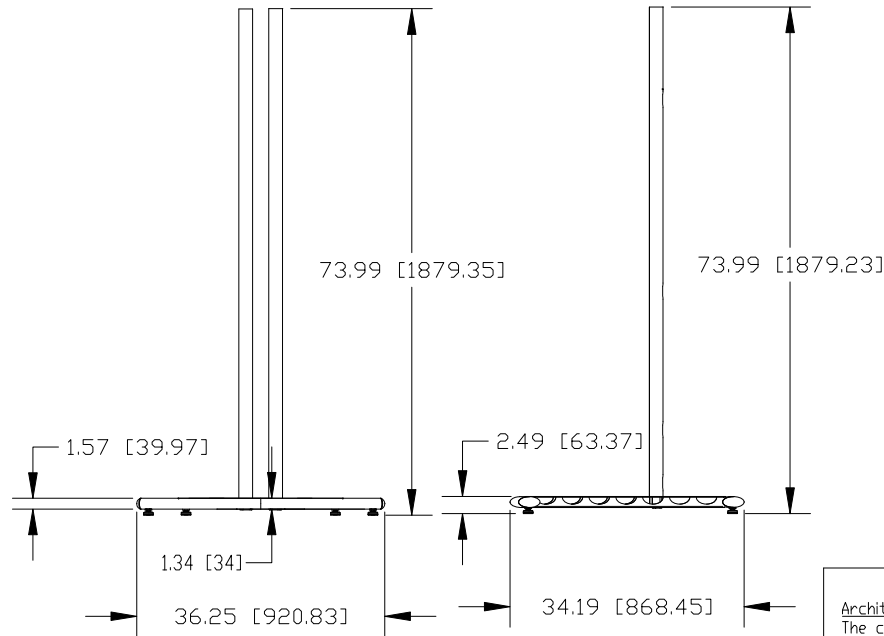
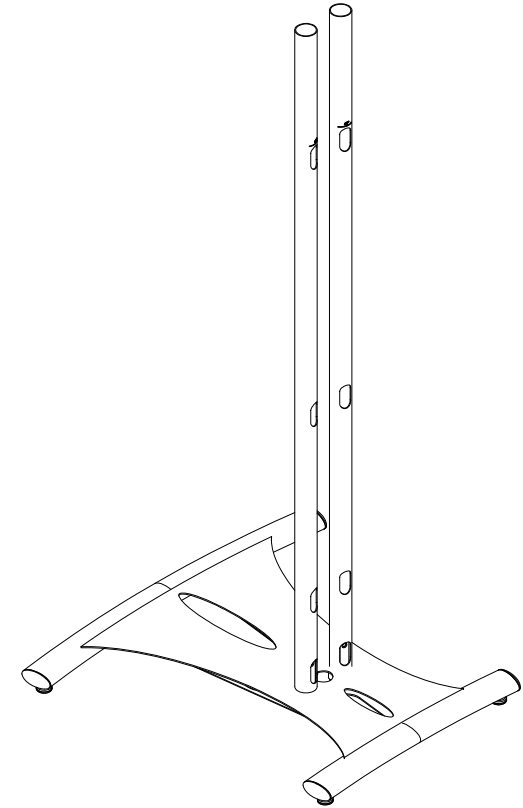
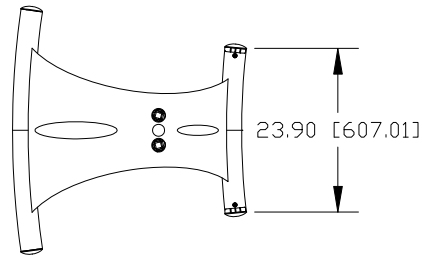

Architectural Specifications

The cart will be a Premier Mounts PSD-EB, or equivalent, and can be used to mount plasma displays. It will be made of cold-rolled steel and will support up to 73kg. It will be UL listed and approved. Assembly and installation will be performed according to the instructions provided by the manufacturer.

Surface Types - Floors

Weight Capacity - 73kg.

Dimensions - Rear: 23.90' (H) x 36.25' (W) x 34.19' (D)

8 7 6 5 4 3 2 1