

PSTA-028(-W)  
PSTK-028(-W)

# Short Throw Projector Mounting Solution

## For ultra-short throw projectors up to 50lb (22kg)

This Universal Ultra-Short Throw Projector Mount (PSTK models) provides flexibility to install to a single stud or a double stud application and gives up to 6" (152mm) of lateral adjustment for perfect projector placement any time. In addition, the universal sliding carriage design of the arm is easily adjustable to accommodate ultra-short throw projector distance requirements. Complementary to the universal design of the ultra-short throw projector arm, this comprehensive package comes with Peerless' Universal Precision Gear Projector Mount that makes image alignment as easy as a simple turn of a knob. Tying the installation together is its internal cable management system that is the oasis of a clean clutter-free installation. Peerless delivers a comprehensive solution in one package for any ultra-short throw projector installation.



Max load: 50lb (22kg)

### FEATURES

- Sliding carriage design allows projector mount to glide into place at any location on the short throw arm
- Access slots allow for all internal cable management
- Pre-installed security screws lockdown short throw arm and prevent tampering
- Kitted with Peerless' Universal Precision Gear Projector Mount (PRG-UNV), patent-pending precision gears that provide exact projector image alignment
- Specifications:  
Tilt:  $\pm 20^\circ$   
Roll:  $\pm 10^\circ$   
Swivel:  $\pm 15^\circ$

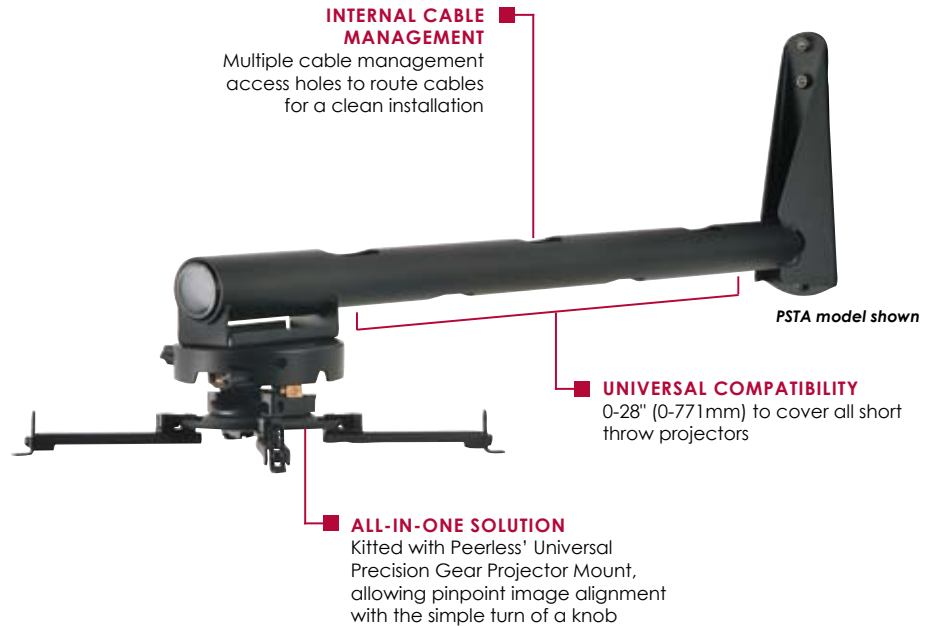

Double stud wall plate allows for 6" (152mm) of lateral adjustment for precise alignment of the ultra-short throw projector, with PSTK model



Post-installation lateral adjustment for optimal arm alignment, with PSTK model



Cable management access holes provide internal cable management



RoHS  
2002/95/EC

**Model Numbers**

<b>PSTA-028</b>	Ultra-short throw projector arm (Includes PRG-UNV) for projectors weighing up to 50lb (22kg)
<b>PSTK-028</b>	Ultra-short throw projector kit (Includes PRG-UNV and wall plate) for projectors weighing up to 50lb (22kg)
<b>PSTA-028-W</b>	Ultra-short throw projector arm (Includes PRG-UNV) for projectors weighing up to 50lb (22kg)
<b>PSTK-028-W</b>	Ultra-short throw projector kit (Includes PRG-UNV and wall plate) for projectors weighing up to 50lb (22kg)

**Product Specifications**

	<b>DIMENSIONS (W x H x D)</b>	<b>PRODUCT WEIGHT</b>	<b>LOAD CAPACITY</b>	<b>FINISH</b>	<b>AVAILABLE COLORS</b>
<b>PSTA-028</b>	3.93" x 11" x 36.20" (100 x 279 x 919mm)	11lb (4kg)	50 lb (22 Kg)	Scratch-resistant fused epoxy	Black and White
<b>PSTK-028</b>	18.50" x 13.11" x 36.62" (470 x 333 x 930mm)	16lb (7kg)			
<b>PSTA-028-W</b>	3.93" x 11" x 36.20" (100 x 279 x 919mm)	11lb (4kg)			
<b>PSTK-028-W</b>	18.50" x 13.11" x 36.62" (470 x 333 x 930mm)	16lb (7kg)			

**Package Specifications**

	<b>PACKAGE SIZE (W x H x D)</b>	<b>PACKAGE SHIP WEIGHT</b>	<b>PACKAGE UPC CODE</b>	<b>PACKAGE CONTENTS</b>	<b>UNITS IN PACKAGE</b>
<b>PSTA-028</b>	17.13" x 4.75" x 45.75" (435 x 120 x 1162mm)	12.24lb (5.5kg)	735029262848	Short throw arm, PRG-UNV, installation hardware, assembly instructions. PSTK Model also includes double stud wall plate.	1
<b>PSTK-028</b>		16.26lb (7.3kg)	735029263043		
<b>PSTA-028-W</b>		12.24lb (5.5kg)	735029262855		
<b>PSTK-028-W</b>		16.26lb (7.3kg)	735029263050		

**Accessories**

- WBK100** Double Stud Wall Plate
- ACC020** Projector Security Cable

All dimensions = inch (mm)

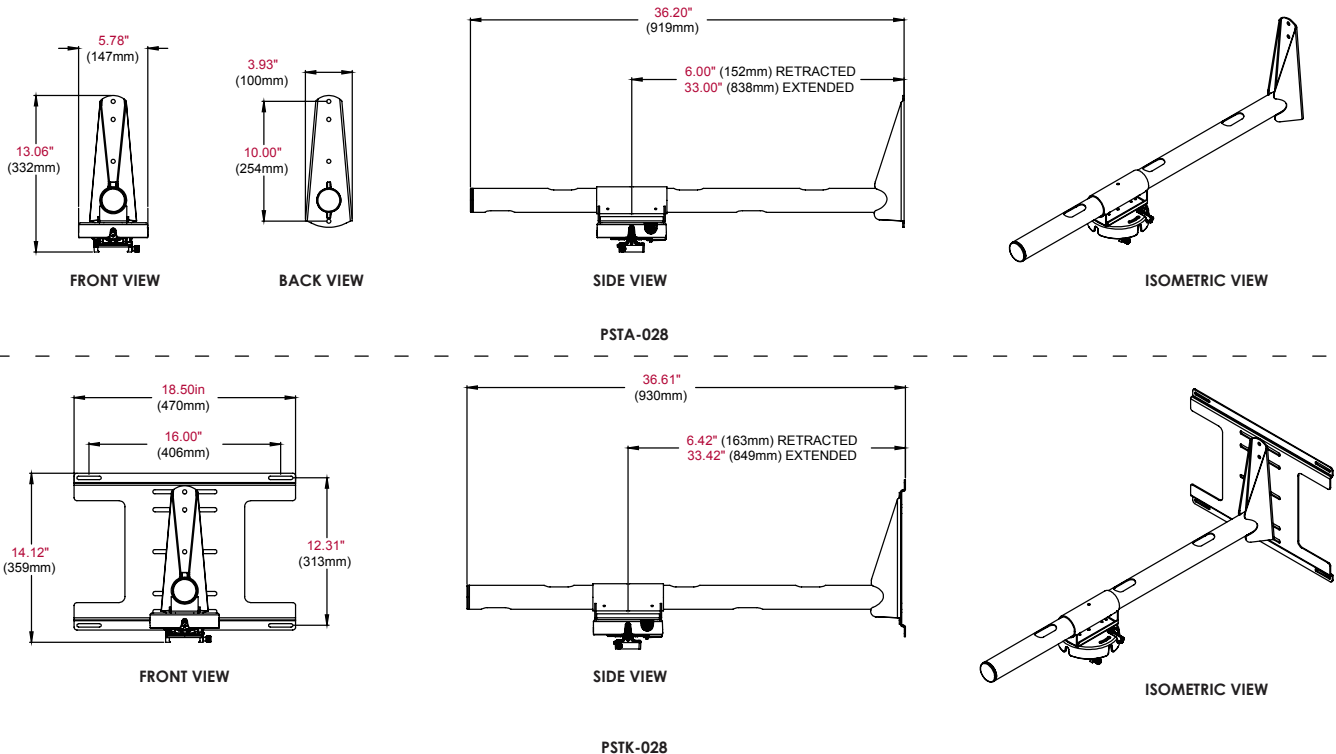

**ARCHITECTS SPECIFICATIONS**

The Universal Projector Wall Arm shall be a Peerless model PST%-028(-W) and shall be located where indicated on the plans. It shall be constructed of heavy gauge cold rolled steel and feature scratch resistant white and black fused epoxy finish. Assembly and installation shall be done according to instructions provided by the manufacturer.