



Lincoln™  
Under-cabinet Light  
Installation Instructions

# Lincoln Under-cabinet Light Installation Instructions

Congratulations on your new Lincoln Under-cabinet Light!

Whether purchased for its significant energy savings and efficiency, lower lifetime costs, environmental considerations, or just to find a better way to light your work area, your Lincoln Under-cabinet Light will provide consistent and reliable light from the highest quality LEDs and components available.

Please read this guide carefully and follow the installation instructions. An electronic version of this guide is also available on our website at [www.workriteergo.com](http://www.workriteergo.com).

Should you have any questions about your Lincoln Under-cabinet Light, refer to the troubleshooting section at the end of this guide. If you still have questions, please contact your sales representative, call Customer Service at 800.959.9675 option "1" or send an email to [customerservice@workriteergo.com](mailto:customerservice@workriteergo.com).

From all of us here at Workrite Ergonomics: Thank you.

---

## Parts

**A** Light Fixture  
Qty: 1

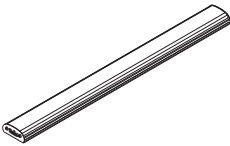

**B** Mounting Kit  
Qty: 2 Wood Mount Brackets with screws  
2 Magnetic Mounts

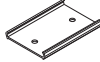

**C** Transformer  
1A, 2A OR 4A  
Qty: 1<sup>1,2,3</sup>

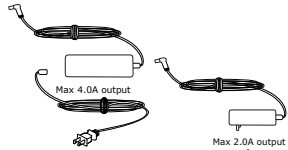

**D** 3-Pin Power Adapter<sup>1</sup>  
Qty: 1



**E** Jumper Cable  
3", 6", 10" or 20"<sup>4</sup>  
Qty: 1



1 Not included with Jumper models (SKUs beginning with LIN-J).

2 Amperage determined by length of light fixture

3 Type A standard. Other plug types available

4 Only included with Jumper models (SKUs beginning with LIN-J)

# Typical Configurations

Stand-Alone



Daisy-Chain



**1**

**Mount Fixture:** Determine if the light will be affixed to a metal or wood cabinet and follow the appropriate directions below.



**Note:** If installing the parent unit of a daisy chain, be sure to position the parent unit so that it can be connected to the additional unit with its supplied jumper cable.

## Metal cabinet mounting:

**a** Snap Magnetic Mounts (B) onto back of Light Fixture (A).

**b** Attach Light Fixture to metal under-cabinet. Magnets will hold the fixture in place.

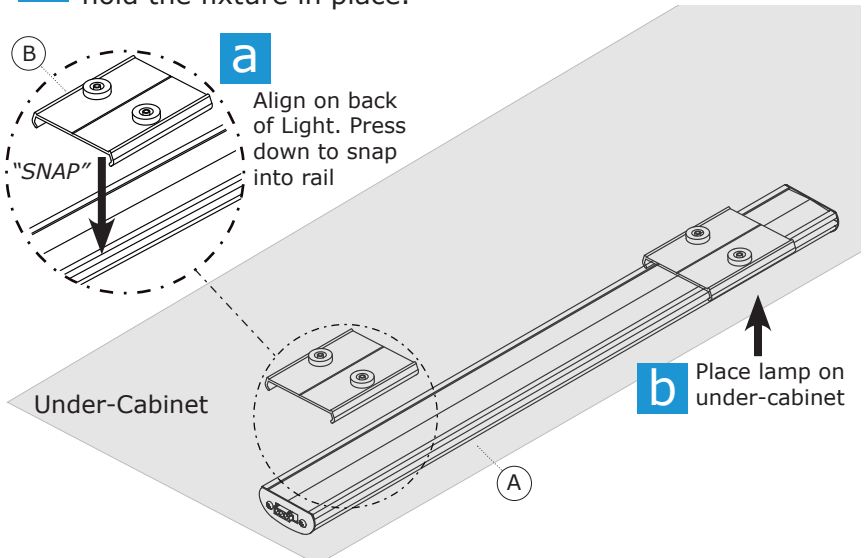

### Wood cabinet mounting:

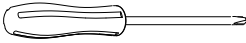

Note: You will need a #2 Phillips-head screwdriver to complete this step.

- a** Determine where you want to mount your Light and draw a straight line on the underside of the cabinet to indicate the center along the length of the Light. Be sure it is far enough away from the front of the cabinet to prevent the Light from protruding out from the edge.
- b** Attach Wood Mounts (B) along your line with Screws provided.
- c** Snap Light Fixture (A) onto mounts to hold in place.

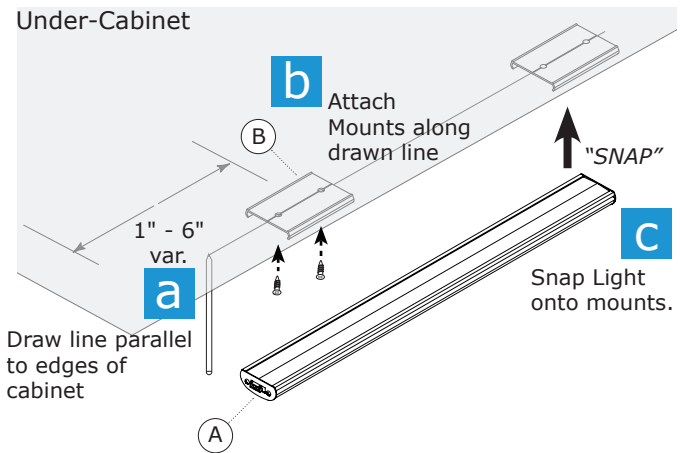

2

Connect Jumper Units to Parent Unit  
(if applicable)

a

Secure Jumper Cable (E) between the plug side of the Parent Unit and the Jumper Unit. The cable should snap into place.

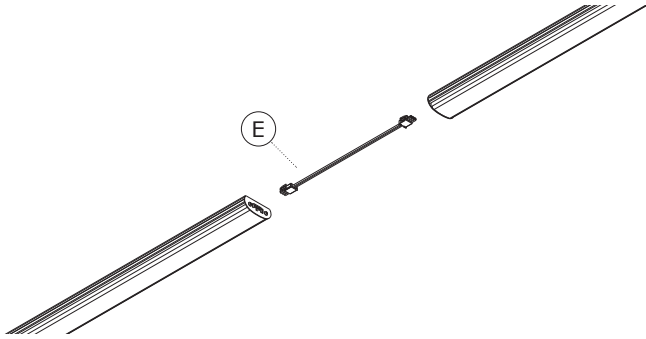

Note: To remove Jumper Cable, depress the clip on the side of the plug and pull gently from the fixture.

 **CAUTION**  
The number of lights that can be daisy-chained together depends on the size of the lights and the size of the transformer. Do not exceed the total number of lights for each of the transformer sizes listed:

**Maximum Daisy-chained units:** Number of fixtures within same chain

2A	under 48" of lights	or 3 lights max
4A	under 120" of lights	or 5 lights max

### 3 Attach Power Adapter

- a Attach Power Adapter (D) to the Parent (or Stand-Alone) unit and the Transformer (C).

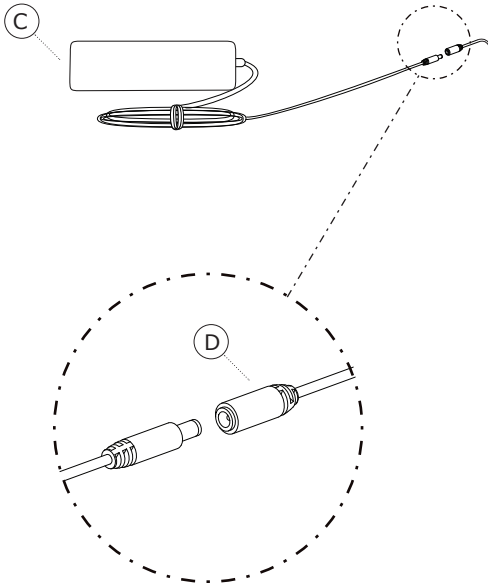

---

### 4 Attach Transformer to Wall Outlet

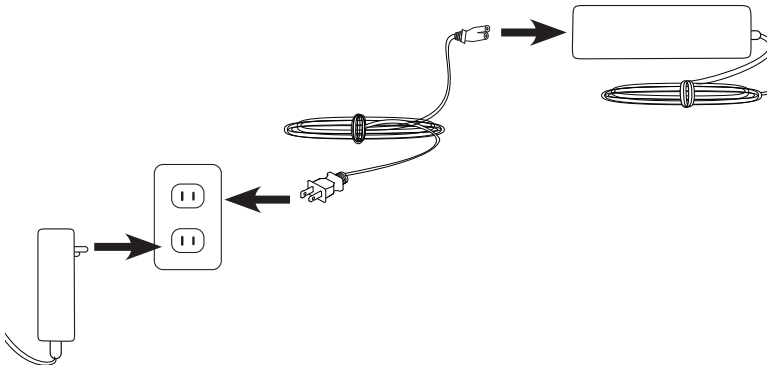

# Troubleshooting Tips

The Lincoln Under-cabinet Light will not turn on

- Check all wire and cable connections. Make sure they are completely and fully engaged.
- Check that the jumper cables or power adapter cables have not come loose from their connectors
- Make sure that the Transformer is plugged into the wall.
- If a daisy chain, ensure the correct transformer is used for the number of LEDs in the chain. All transformers should be Class 2, 12V transformers. Refer to the Table in Step 2 for required current ratings.
- Check that the outlet has power.

The Lincoln Under-cabinet Light flashes on and off

- Unplug the transformer and locate the label. Make sure that the transformer is ONLY a Class 2, 12V transformer at 1A (1000mA), 2A (2000mA), or 4A depending on how many LEDs are connected.

The Lincoln Under-cabinet Light dims or goes out.

- Make sure there are not too many lights in the daisy chain for the rating of the transformer. Refer to the Table in Step 2 for guidance.
- Check all wire and cable connections. Make sure they are completely and fully engaged.
- Check that the outlet has power.

The Lincoln Under-cabinet Light will not turn on when I come back into the work area

- The occupancy sensor has a listed range of 15'. However, if a lip of the cabinet or other object blocks the full view of the sensor, then it may have trouble detecting the presence of a person in the work area. Reposition the light to have a better view of the work space.

Troubleshooting Tips, continued

The Lincoln Under-cabinet Light with an occupancy sensor will not turn off

- The time on the occupancy sensor automatic shutoff is set at the factory for 15 minutes. Cover the occupancy sensor and record how long it takes for the light to turn itself off.
- If the Lincoln Under-cabinet Light is place near a walkway, aisle way or adjacent to another workstation, the light may receive signals that the space it is monitoring is occupied and the light won't shut off. Try to reposition the light away from aisle ways.

If problems persist, please contact your sales representative or Workrite Customer Service.

---

Replacement parts

Mounting Kit .....	LIN-MOUNT
Power Adapter .....	LIN-3PIN-PWR
3" Jumper Cable.....	LIN-3PIN-J-03
6" Jumper Cable.....	LIN-3PIN-J-06
10" Jumper Cable .....	LIN-3PIN-J-10
20" Jumper Cable .....	LIN-3PIN-J-20
1A Transformer .....	LIN-T15
2A Transformer .....	LIN-T25
4A Transformer .....	LIN-T45