

Important Safety Instructions

Read and understand all these safety instructions before using the product.











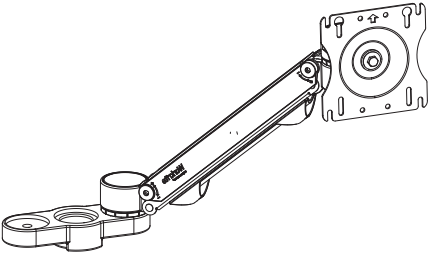
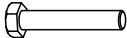





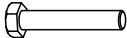





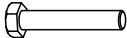





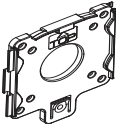





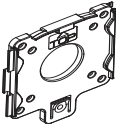

Do not mount the Desk Base of the Willow Arm on an unstable surface or any surface that could not mount the Desk Base firmly.

During installation, beware of the recoil of the Willow Arm body when attaching or detaching the monitor to the Willow Arm. To prevent damage or injury when changing the monitor, always raise the Arm to its highest position before the monitor is detached. *The Willow Arm can support monitors from 1 to 14 pounds.*

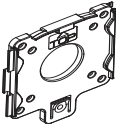
Do not attempt to disassemble, service or modify the product.

Use only a slightly damp cloth to clean the Willow Arm surface. Never use flammable solvents like alcohol, benzene, thinner, etc. on the product.

Parts grouped by package

<p>A Willow Arm Assembly Qty: 1</p> 	<table border="0"> <tr> <td data-bbox="711 806 1036 968"> <p>I 5/16" x 18 x 1 3/4" Hex Bolt Qty: 1</p>  </td> <td data-bbox="1052 806 1247 968"> <p>J 3/8"x16 Lock Nut Qty: 2</p>  </td> <td data-bbox="1263 806 1523 968"> <p>K Metal Washer Qty: 1</p>  </td> </tr> <tr> <td data-bbox="711 1010 1036 1171"> <p>L Plastic Washer Qty: 1</p>  </td> <td data-bbox="1052 1010 1247 1171"> <p>M Steel Cup Qty: 1</p>  </td> <td data-bbox="1263 1010 1523 1171"> <p>N Pivot Bushing Qty: 1</p>  </td> </tr> <tr> <td data-bbox="711 1220 1036 1381"> <p>O Plastic Spacer Qty: 1</p>  </td> <td colspan="2"></td> </tr> </table>			<p>I 5/16" x 18 x 1 3/4" Hex Bolt Qty: 1</p> 	<p>J 3/8"x16 Lock Nut Qty: 2</p> 	<p>K Metal Washer Qty: 1</p> 	<p>L Plastic Washer Qty: 1</p> 	<p>M Steel Cup Qty: 1</p> 	<p>N Pivot Bushing Qty: 1</p> 	<p>O Plastic Spacer Qty: 1</p> 		
<p>I 5/16" x 18 x 1 3/4" Hex Bolt Qty: 1</p> 	<p>J 3/8"x16 Lock Nut Qty: 2</p> 	<p>K Metal Washer Qty: 1</p> 										
<p>L Plastic Washer Qty: 1</p> 	<p>M Steel Cup Qty: 1</p> 	<p>N Pivot Bushing Qty: 1</p> 										
<p>O Plastic Spacer Qty: 1</p> 												
<table border="0"> <tr> <td data-bbox="120 1182 363 1409"> <p>B Quick Release Bracket Qty: 1</p>  </td> <td data-bbox="402 1182 662 1325"> <p>F 10mm Plastic Spacers Qty: 4</p>  </td> </tr> <tr> <td data-bbox="120 1461 363 1598"> <p>C M4x18 Phillips Screws Qty: 4</p>  </td> <td data-bbox="402 1377 662 1520"> <p>G Pivot Cover Cap Qty: 1</p>  </td> </tr> <tr> <td data-bbox="120 1629 363 1766"> <p>D M4x12 Phillips Screws Qty: 4</p>  </td> <td data-bbox="402 1535 662 1703"> <p>H 3/16" Allen Wrench Qty: 1</p>  </td> </tr> <tr> <td data-bbox="120 1818 363 1955"> <p>E M4x8 Phillips Screws Qty: 4</p>  </td> <td></td> </tr> </table>	<p>B Quick Release Bracket Qty: 1</p> 	<p>F 10mm Plastic Spacers Qty: 4</p> 	<p>C M4x18 Phillips Screws Qty: 4</p> 	<p>G Pivot Cover Cap Qty: 1</p> 	<p>D M4x12 Phillips Screws Qty: 4</p> 	<p>H 3/16" Allen Wrench Qty: 1</p> 	<p>E M4x8 Phillips Screws Qty: 4</p> 		<p>Verify that you have all the hardware and tools needed for the assembly</p> <p>Check your packages against the parts list to verify that you have all the parts needed.</p> <p>You will also need the following tools:</p> <ul style="list-style-type: none"> 9/16" end wrench or socket 5/8" end wrench or socket 1/2" end wrench or socket 			
<p>B Quick Release Bracket Qty: 1</p> 	<p>F 10mm Plastic Spacers Qty: 4</p> 											
<p>C M4x18 Phillips Screws Qty: 4</p> 	<p>G Pivot Cover Cap Qty: 1</p> 											
<p>D M4x12 Phillips Screws Qty: 4</p> 	<p>H 3/16" Allen Wrench Qty: 1</p> 											
<p>E M4x8 Phillips Screws Qty: 4</p> 												

- 1** Disassemble existing Willow Arm at high end of extension
Loosen any monitor cables and remove from cable managers. Remove and set existing monitor aside. When removing remaining parts, set them aside for later use. **DO NOT DISCARD PARTS.**

- a** Using a small push pin or sharp object remove chrome cover.
- b** Remove $\frac{3}{8}$ "x16x2" Hex Bolt from joint with a $\frac{9}{16}$ " wrench or socket while holding the castleated locking nut from below extension with a $\frac{5}{8}$ " wrench or socket. Then remove washers and steel cup.
- c** Remove existing arm assembly from joint.
- d** Remove pivot bushing from extension joint.
- e** Remove steel cup and castleated locking nut from below extension.

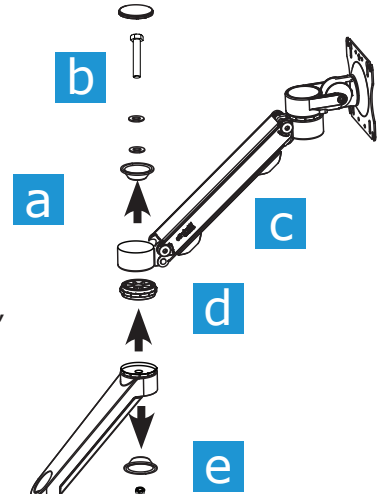

2 Attach new Arm Assembly to extension

Use parts removed in Step 1 above.

- a** Insert $\frac{3}{8}$ "x16x2" Hex Bolt , metal washer, plastic washer and steel cup into top of Dual Hub.
- b** Connect bolt through Hub to pivot bushing, then to arm extension.
- c** Insert steel cup and castleated locking nut into recessed area below extension.
- d** Tighten with $\frac{5}{8}$ " wrench or socket on the bottom and $\frac{9}{16}$ " wrench or socket on top.
- e** Snap chrome cover to top of arm.

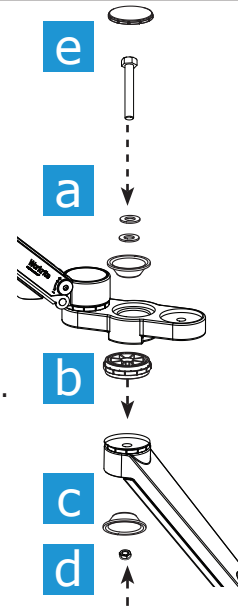

3 Attach original arm to Hub using new parts from hardware kit

- a** Insert Hex Bolt (I) into Plastic Spacer (O) then into arm extension from the bottom.
- b** Insert Pivot Bushing (N), onto bolt on top of arm extension.
- c** Place Metal Washer (K), Plastic Washer (L) and Steel Cup (M) into original arm and place onto bolt.
- d** Attach Lock Nut (J) onto top of bolt.
- e** Tighten with $\frac{1}{2}$ " end wrench or socket.
- e** Snap Pivot Cover Cap (G) to top of original arm.

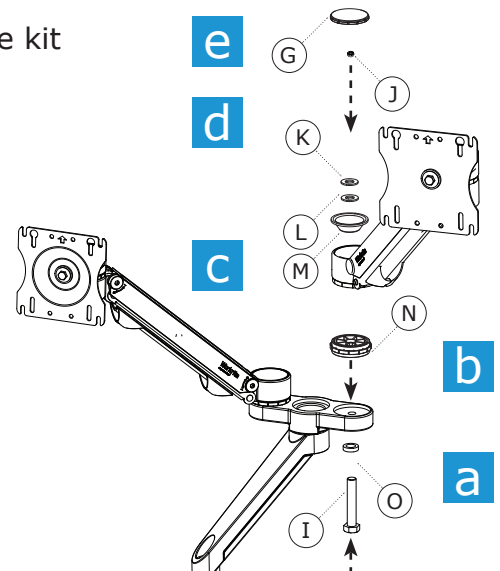

4 Attach Monitors



Important Note

It is strongly recommended to use the mounting screws provided by the monitor manufacturer if possible. If longer screws are needed, use either part (C) 18mm long, (D) 12mm long, or (E) 8mm long. NOTE: Always use the shortest screws possible to avoid damage to the monitor.

Quick Release Option:

- a** Attach the Quick Release Bracket (B) to the VESA mount holes on your monitor. Use the screws from your monitor if possible. The tab on the bracket should be on the bottom.

For Recessed Mounts:

For monitors with recessed mount where the Quick Release Bracket will not fit into the mounting location, 10mm Plastic Spacers (F) have been supplied. Install these between the monitor and the Quick Release Bracket as shown with the shortest M4 screws possible.

- b** Attach the Willow Arm to the monitor by sliding the Quick Release Bracket over the mounting plate.

Note: Your Quick Release Bracket has convenient storage on its side for the $\frac{3}{16}$ " Allen Wrench (H).

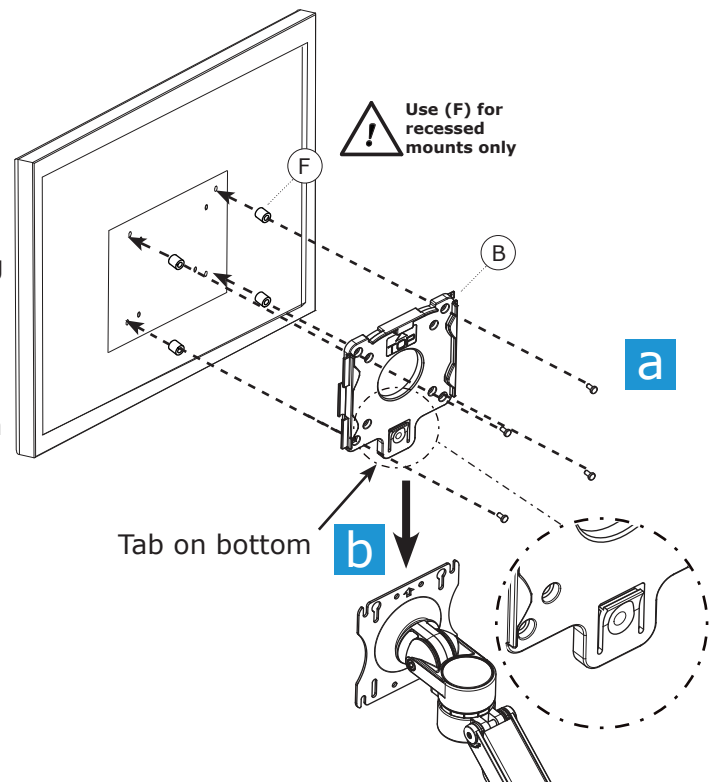
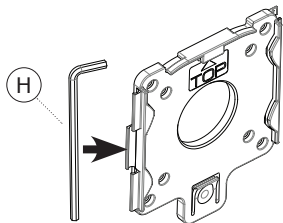

OR

Direct/Secure Mount Option:

- a** Attach the Willow Arm VESA mount to the VESA mount holes on your monitor. Use the screws from your monitor if possible. The clip on the bracket should be on the bottom.

For Recessed Mounts:

For monitors with recessed area where the VESA mount will not fit into the mounting location, 10mm Plastic Spacers (F) have been supplied. Install these between the monitor and the VESA mount as shown with the shortest M4 screws possible.

Note: Keep your Quick Release Bracket (B) for possible future use.

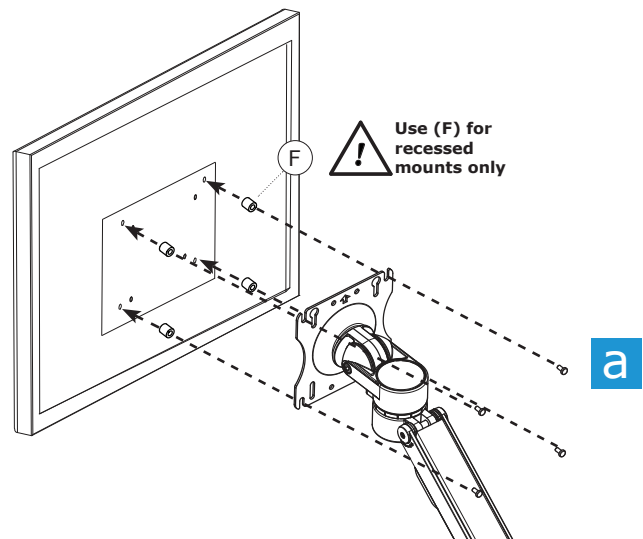

5 Cable Management

- a** Upper arm: Insert cables into the recessed area under the upper arm by spreading the clips apart.
- b** Lower arm: Pull cover off the underside of the extension, place cables into recess, then snap cover back on.
- c** Desk Base: If using the Grommet Mount, you can thread cables into the grommet hole using the indentation in the base.

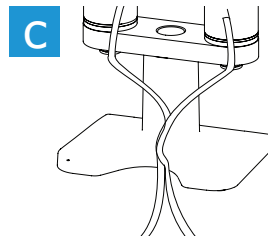

Grommet mount only

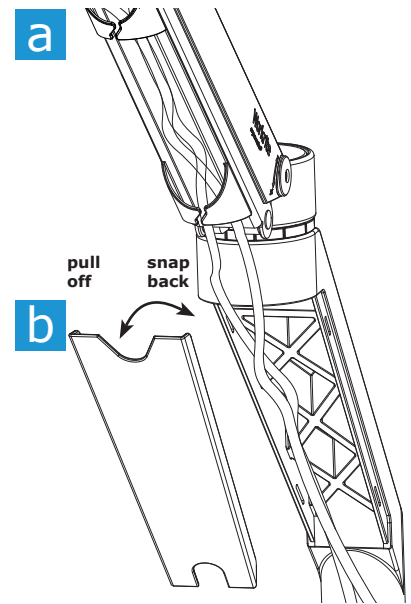

6 Adjust the Monitor Tilt Action

Depending on the size of your monitor, it may be necessary to adjust the tilt setting.

If the monitor doesn't hold its tilt position or is too hard to tilt, adjust the screw directly behind the monitor on the side of the arm. Use the $\frac{3}{16}$ " Allen Wrench (H) (clockwise to tighten, counter-clockwise to loosen). Check the monitor, and adjust again as necessary.

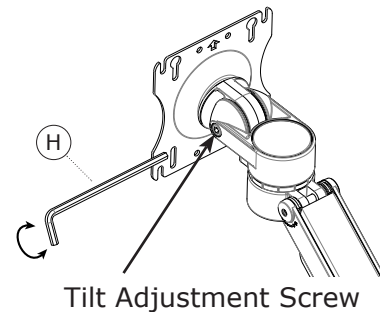

Tilt Adjustment Screw

7 Adjust the Monitor Vertical Movement

The Willow Arm is preset to balance a 6-pound monitor. If your monitor weighs more or less than this, it may be necessary to adjust the friction of the arm. Test the friction by raising the arm all the way up, waiting to see if it moves, and then lowering the arm all the way down. If the arm drops from the top or rises off the bottom, you will need to adjust the friction.

Use the $\frac{3}{16}$ " Allen Wrench (H) to make small adjustments in the arm friction by turning the screws in each end of the upper arm. Always turn both screws the same amount in small steps, until the arm no longer rises or falls. Do not overtighten or the arm will be too stiff to make easy adjustments in monitor position.

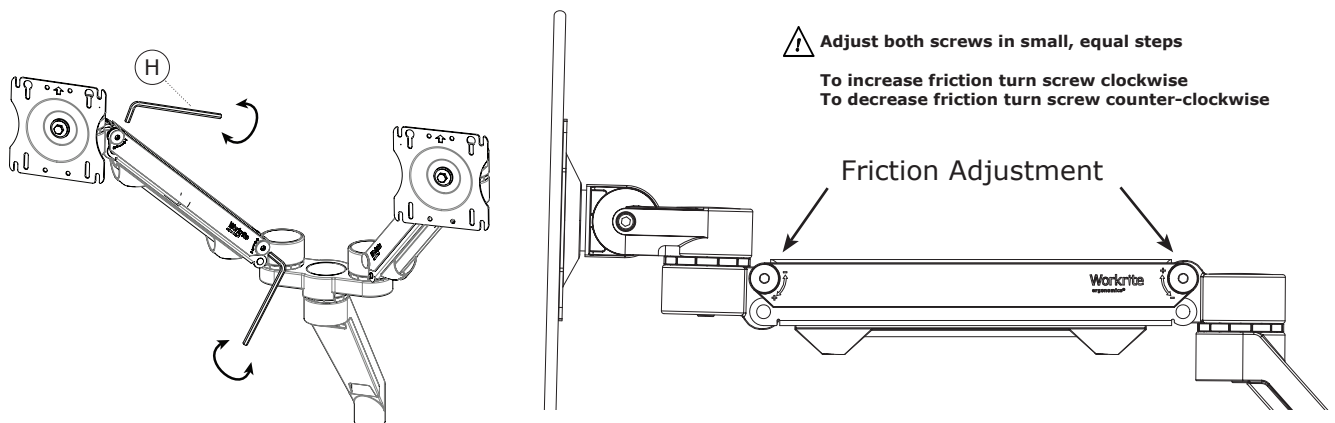

⚠ Adjust both screws in small, equal steps

To increase friction turn screw clockwise
To decrease friction turn screw counter-clockwise

Friction Adjustment