

Important Safety Instructions

Read and understand all these safety instructions before using the product.

Do not mount the Desk Base of the Willow Arm on an unstable surface or any surface that could not mount the Desk Base firmly.











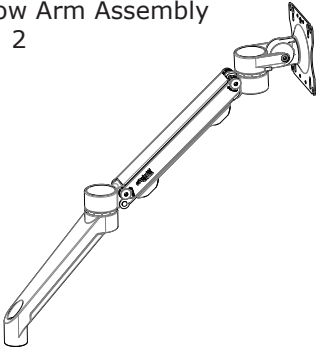

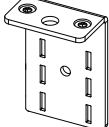







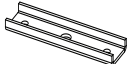
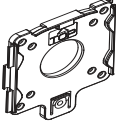

During installation, beware of the recoil of the Willow Arm body when attaching or detaching the monitor to the Willow Arm. To prevent damage or injury when changing the monitor, always raise the Arm to its highest position before the monitor is detached. *The Willow Arm can support monitors from 1 to 14 pounds.*

Do not attempt to disassemble, service or modify the product.

Use only a slightly damp cloth to clean the Willow Arm surface. Never use flammable solvents like alcohol, benzene, thinner, etc. on the product.

Parts grouped by carton

WA2000-C-S only OR WA2000-G-S only

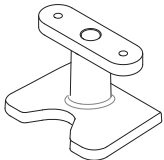
<p>A Willow Arm Assembly Qty: 2</p> 	<p>J Upper Clamp Bracket Qty: 1</p>  <p>K Lower Clamp Bracket Qty: 1</p>  <p>L 1/4" x 20 x 3/8" Phillip Flat Head Screws Qty: 2</p>  <p>M 3/8" x 16 x 3 1/2" Hex Bolt Qty: 1</p>  <p>N Plastic Clamp Knob Qty: 1</p>  <p>O Plastic Clamp Pad Qty: 1</p> 	<p>P 3/8" x 16 x 4 1/2" Threaded Stud Qty: 1</p>  <p>Q 3/8" Steel Washer Qty: 1</p>  <p>R 3/8" x 16 Hex Nut Qty: 1</p>  <p>S U-Bracket Qty: 1</p> 
<p>B Quick Release Bracket Qty: 2</p>  <p>F 10mm Plastic Spacers Qty: 8</p>  <p>G Pivot Cover Cap Qty: 2</p>  <p>C M4x18 Phillips Screws Qty: 8</p>  <p>D M4x12 Phillips Screws Qty: 8</p>  <p>H 3/16" Allen Wrench Qty: 1</p> 	<p>T Plastic Pivot Washer Qty: 2</p>  <p>U Flange Pin Qty: 2</p>  <p>V 3/8"x16x2 1/2" Button Head Allen Cap Screw Qty: 2</p>  <p>W 3/8"x16 Lock Nut Qty: 2</p>  <p>X 3/8" ID Belleville Spring Washer Qty: 2</p> 	
<p>E M4x8 Phillips Screws Qty: 8</p>  <p>I Desk Base Qty: 1</p> 		

Verify that you have all the hardware and tools needed for the assembly

Check your packages against the parts list on page 1 to verify that you have all the parts needed.

You will also need the following tools:

#3 tip Phillips screwdriver

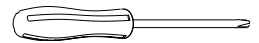

1 Assemble Base

Clamp Mount: WA2000-C-S only

- a** Assemble Clamp - Thread Hex Bolt (M) through Knob (N) and Upper Clamp Bracket (J) and tighten securely. Press the Plastic Clamp Pad (O) onto the end of the Bolt.
- b** Mount Lower Clamp Bracket (K) to Desk Base with Screws (L) and tighten using a #3 Phillips Screw Driver.
- c** Put Desk Base (I) onto work surface then slide teeth of Clamp into Bracket slots. Use the highest slots possible for best clamping. Turn knob to tighten.

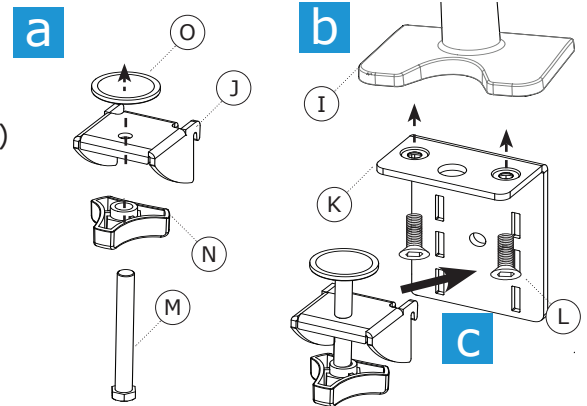

OR

Grommet Mount: WA2000-G-S only

- a** Drill bolting hole in worksurface if needed. Put Desk Base (I) directly on the bolting hole of worksurface and insert and tighten the $\frac{3}{8}$ " x 16 x $4\frac{1}{2}$ " threaded Stud (P).
- b** Place the U-Bracket (S) onto the Threaded Stud with the flat bottom of the U facing down.
- c** Place the $\frac{3}{8}$ " Steel Washer (Q) followed by the $\frac{3}{8}$ " x 16 Hex Nut (R) onto the Threaded Stud and tighten securely.

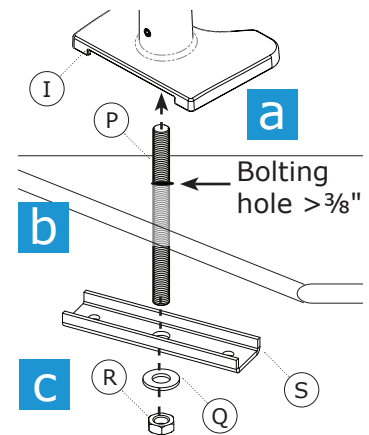

2 Attach Willow Arms to Desk Base

- a** Place the Plastic Washer (T) to go onto the Flange Pin (U).
- b** Insert the Flange Pin into the bottom of the arm.
- c** Place the Screw (V) and Belleville Washer (X) into the arm from the top.
- d** Thread the screw into the Desk Base (I). Tighten until the arm is firm but spins with light friction with the $\frac{3}{16}$ " Allen wrench (H).
- e** Place the Lock Nut (W) onto the screw extending through the Desk Base. While holding the screw with the $\frac{3}{16}$ " Allen wrench to keep it from turning and loosening, tighten the lock nut firmly to keep the screw from loosening during use.
- f** Snap Pivot Cover Cap (G) into top of Arm Assembly.
- g** Repeat for second Willow Arm.

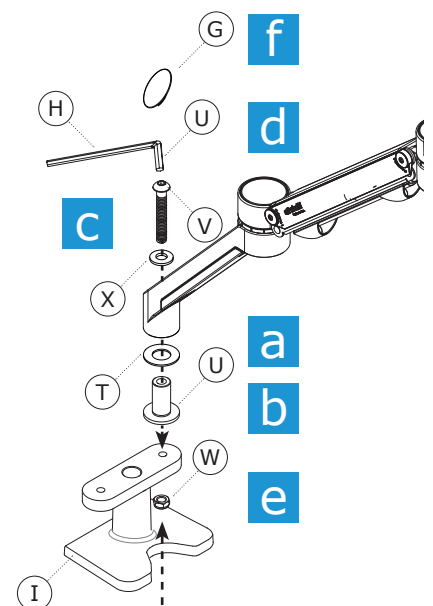

3

Attach Monitors



Important Note

It is strongly recommended to use the mounting screws provided by the monitor manufacturer if possible. If longer screws are needed, use either part (C) 18mm long, (D) 12mm long, or (E) 8mm long. NOTE: Always use the shortest screws possible to avoid damage to the monitor.

Quick Release Option:

- a** Attach the Quick Release Bracket (B) to the VESA mount holes on your monitor. Use the screws from your monitor if possible. The tab on the bracket should be on the bottom.

For Recessed Mounts:

For monitors with recessed mount where the Quick Release Bracket will not fit into the mounting location, 10mm Plastic Spacers (F) have been supplied. Install these between the monitor and the Quick Release Bracket as shown with the shortest M4 screws possible.

- b** Attach the Willow Arm to the monitor by sliding the Quick Release Bracket over the mounting plate.

Note: Your Quick Release Bracket has convenient storage on its sides for the $\frac{3}{16}$ " Allen Wrench (H).

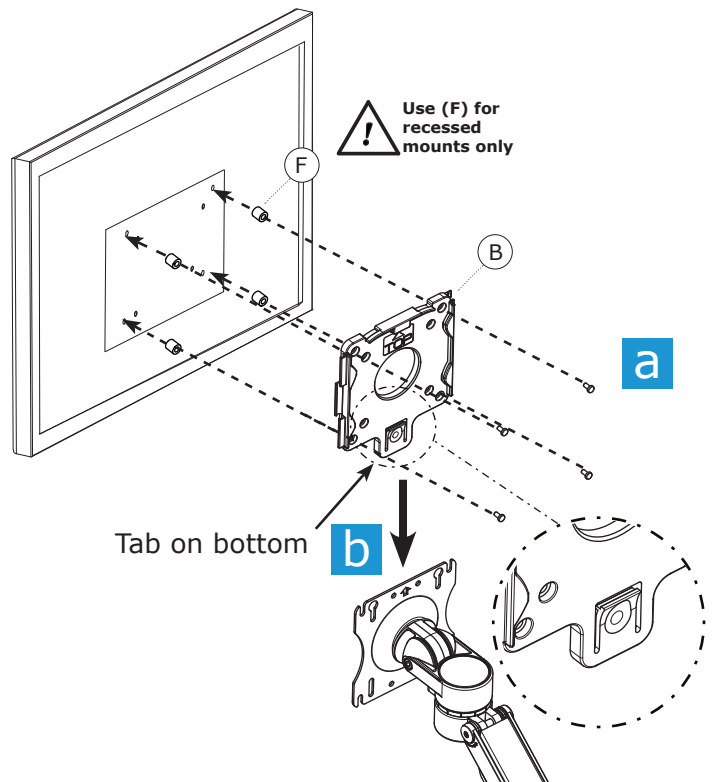
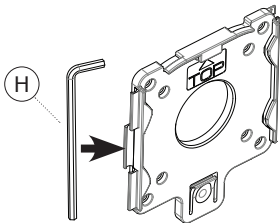

OR

Direct/Secure Mount Option:

- a** Attach the Willow Arm VESA mount to the VESA mount holes on your monitor. Use the screws from your monitor if possible. The clip on the bracket should be on the bottom.

For Recessed Mounts:

For monitors with recessed area where the VESA mount will not fit into the mounting location, 10mm Plastic Spacers (F) have been supplied. Install these between the monitor and the VESA mount as shown with the shortest M4 screws possible.

Note: Keep your Quick Release Bracket (B) for possible future use.

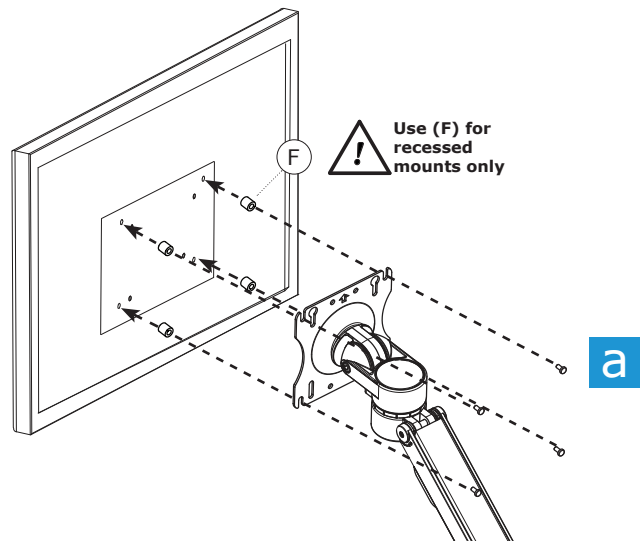

4 Cable Management

- a** Upper arm: Insert cables into the recessed area under the upper arm by spreading the clips apart.
- b** Lower arm: Pull cover off the underside of the extension, place cables into recess, then snap cover back on.
- c** Desk Base: If using the Grommet Mount, you can thread cables into the grommet hole using the indentation in the base.

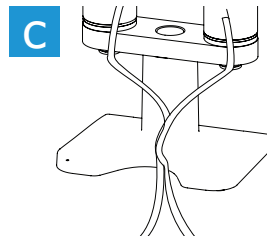

Grommet mount only

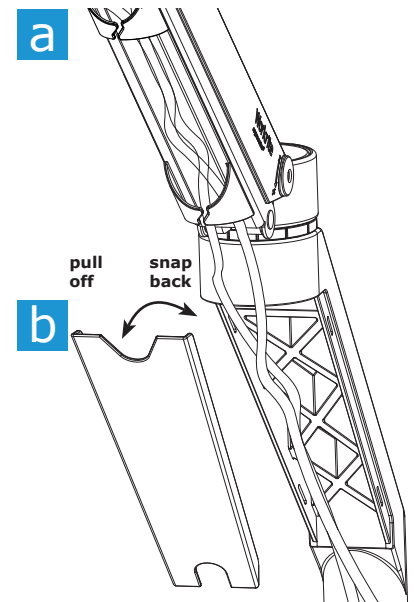

5 Adjust the Monitor Tilt Action

Depending on the size of your monitor, it may be necessary to adjust the tilt setting.

If the monitor doesn't hold its tilt position or is too hard to tilt, adjust the screw directly behind the monitor on the side of the arm. Use the $\frac{3}{16}$ " Allen Wrench (H) (clockwise to tighten, counter-clockwise to loosen). Check the monitor, and adjust again as necessary.

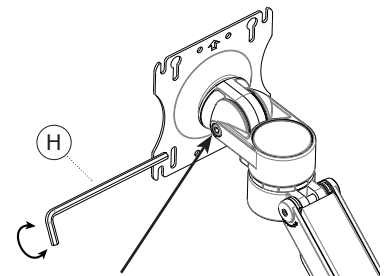

Tilt Adjustment Screw

6 Adjust the Monitor Vertical Movement

The Willow Arm is preset to balance a 6-pound monitor. If your monitor weighs more or less than this, it may be necessary to adjust the friction of the arm. Test the friction by raising the arm all the way up, waiting to see if it moves, and then lowering the arm all the way down. If the arm drops from the top or rises off the bottom, you will need to adjust the friction.

Use the $\frac{3}{16}$ " Allen Wrench (H) to make small adjustments in the arm friction by turning the screws in each end of the upper arm. Always turn both screws the same amount in small steps, until the arm no longer rises or falls. Do not overtighten or the arm will be too stiff to make easy adjustments in monitor position.

