

**BALT**<sup>®</sup>

**Split-Level-36**  
Task Table

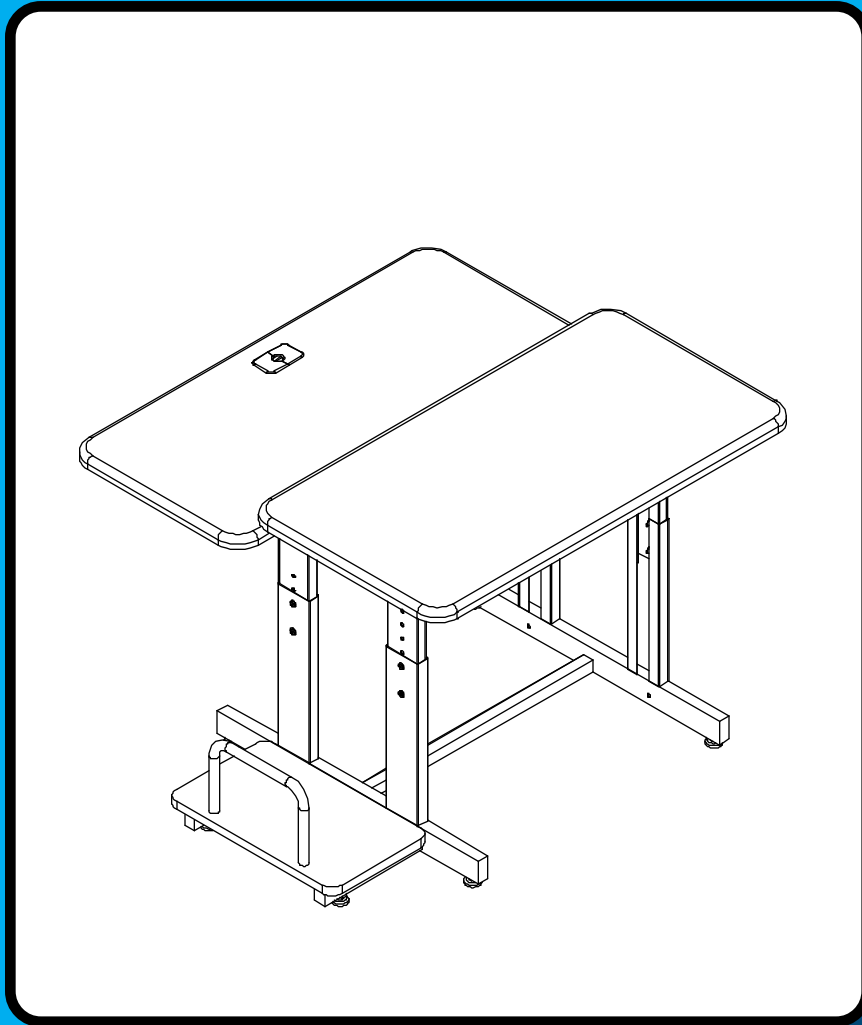

**Assembly Instructions**

# Split-Level-36

## Task Table



Part	Drawing	Description	Qty	Part	Drawing	Description	Qty																																
P1		Monitor Platform	1 EA	P8		CPU Rail	1 EA																																
P2		Keyboard Platform	1 EA	P9		CPU Foot	2 EA																																
P3		Upper Insert Left Front & Right Back	2 EA	P10		CPU Platform	1 EA																																
P4		Upper Insert Right Front & Left Back	2 EA	<div style="border: 1px solid black; border-radius: 15px; padding: 10px;"> <h3 style="text-align: center;">Hardware List</h3> <table border="0"> <tr> <td>A</td> <td></td> <td>9/16" Socket Screw</td> <td>16 EA</td> </tr> <tr> <td>A1</td> <td></td> <td>1-7/8" Socket Screw</td> <td>10 EA</td> </tr> <tr> <td>A2</td> <td></td> <td>1-1/2" Socket Screw</td> <td>4 EA</td> </tr> <tr> <td>B</td> <td></td> <td>2-3/8" Socket Screw</td> <td>8 EA</td> </tr> <tr> <td>C</td> <td></td> <td>Square Nut</td> <td>8 EA</td> </tr> <tr> <td>E</td> <td></td> <td>Plastic Grommet</td> <td>1 EA</td> </tr> <tr> <td>F</td> <td></td> <td>Glide</td> <td>6 EA</td> </tr> <tr> <td>G</td> <td></td> <td>Allen Wrench</td> <td>1 EA</td> </tr> </table> </div>				A		9/16" Socket Screw	16 EA	A1		1-7/8" Socket Screw	10 EA	A2		1-1/2" Socket Screw	4 EA	B		2-3/8" Socket Screw	8 EA	C		Square Nut	8 EA	E		Plastic Grommet	1 EA	F		Glide	6 EA	G		Allen Wrench	1 EA
A		9/16" Socket Screw	16 EA																																				
A1		1-7/8" Socket Screw	10 EA																																				
A2		1-1/2" Socket Screw	4 EA																																				
B		2-3/8" Socket Screw	8 EA																																				
C		Square Nut	8 EA																																				
E		Plastic Grommet	1 EA																																				
F		Glide	6 EA																																				
G		Allen Wrench	1 EA																																				
P5		Stability Panel	2 EA																																				
P6		Crossbrace	3 EA																																				
P7		Leg Receiver	2 EA																																				

*We recommend that you assemble this unit on a table.*

Tools required: Adjustable Crescent Wrench

### Missing Parts or UPS Damaged Parts

For Your Convenience you can  
EMAIL us at  
**[furniture@baltinc.com](mailto:furniture@baltinc.com)**  
24HOURS 7 DAYS A WEEK

***Should you require assistance during assembly,  
please call our Customer Service Department  
Monday - Friday 8 a.m. - 5 p.m.  
Central Standard Time 1-800-749-2258***

Do not use unless all screws are tight. At least every six months, check all screws to be sure they are tight. If parts are missing, broken, damaged, or worn, stop use of the product until repairs are made by your dealer using factory authorized parts.

# Split-Level-36 Assembly Diagram



**READ THROUGH INSTRUCTIONS FROM BEGINNING TO END BEFORE STARTING TO ASSEMBLE UNIT.**

1.) Identify and Separate all the Parts and Hardware.

2.) Place the Monitor Platform (P1) with the insert nuts facing up. Attach 1 each Upper Insert (P3) and 1 each Upper Insert (P4) using 4 each (B) screws.  
**(Finger tighten only)**

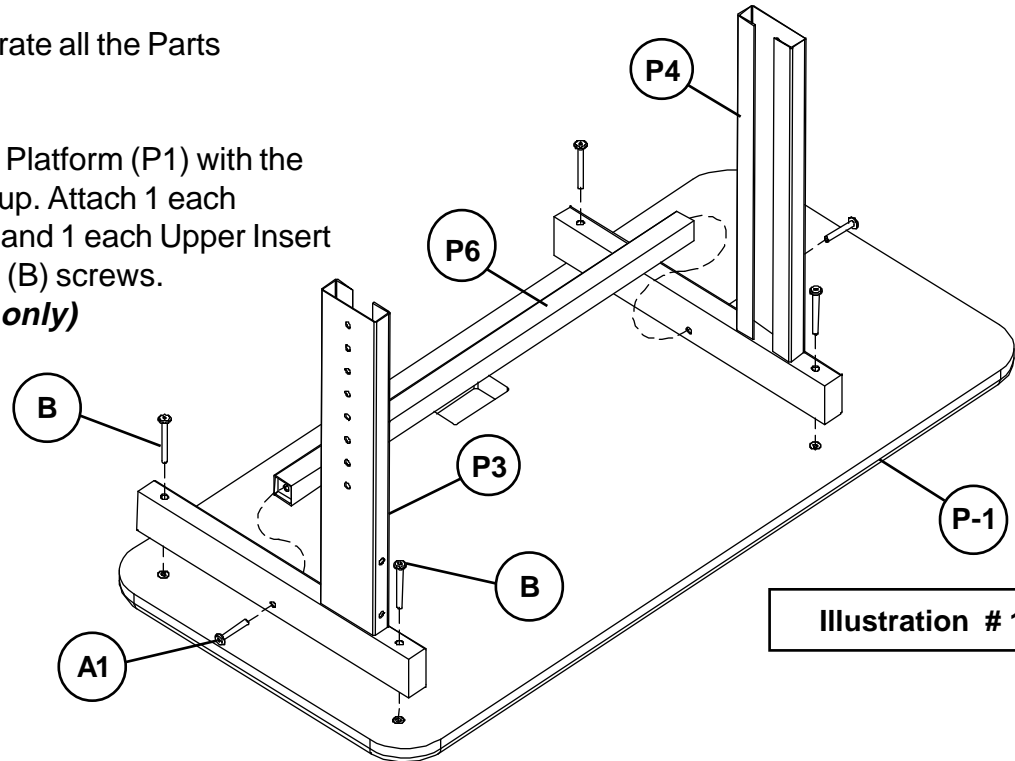

3.) Attach Crossbrace (P6) between the Upper Inserts (P3 & P4) using 2 Screws (A1) as shown in illustration #1.

4.) Attach Stability Panel (P5) to the Upper Inserts (P3 & P4) using 4 Screws (A) as shown in illustration #2.

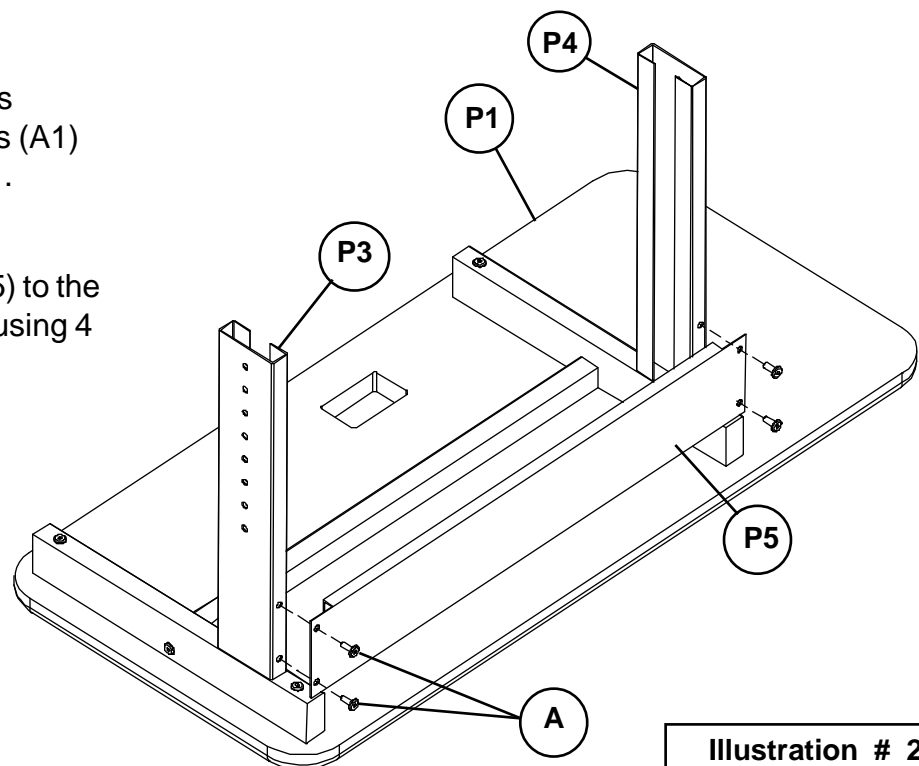

- 5.) Place the Keyboard Platform (P2) with the insert nuts facing up. Attach 1 each Upper Insert (P3) and 1 each Upper Insert (P4) using 4 each (B) screws.  
**(Finger tighten only)**

Illustration # 3

- 6.) Attach Crossbrace (P6) to the Upper Inserts (P3 & P4) using 2 Screws (A1) as shown in illustration #3.

- 7.) Attach Stability Panel (P5) to the Upper Inserts (P3 & P4) using 4 Screws (A) as shown in illustration #3.

- 8.) Slide 2 Leg Receivers (P7) over 2 Upper Inserts (P3) and 2 Upper Inserts (P4) as shown in illustration #4. Secure at desired height using 8 each (A) Screws and 8 each (C) Square nuts (flat side of the nut should be next to the metal).

- 9.) Attach 4 each (F) Leveling Glides to the 2 each Leg receivers (P7).

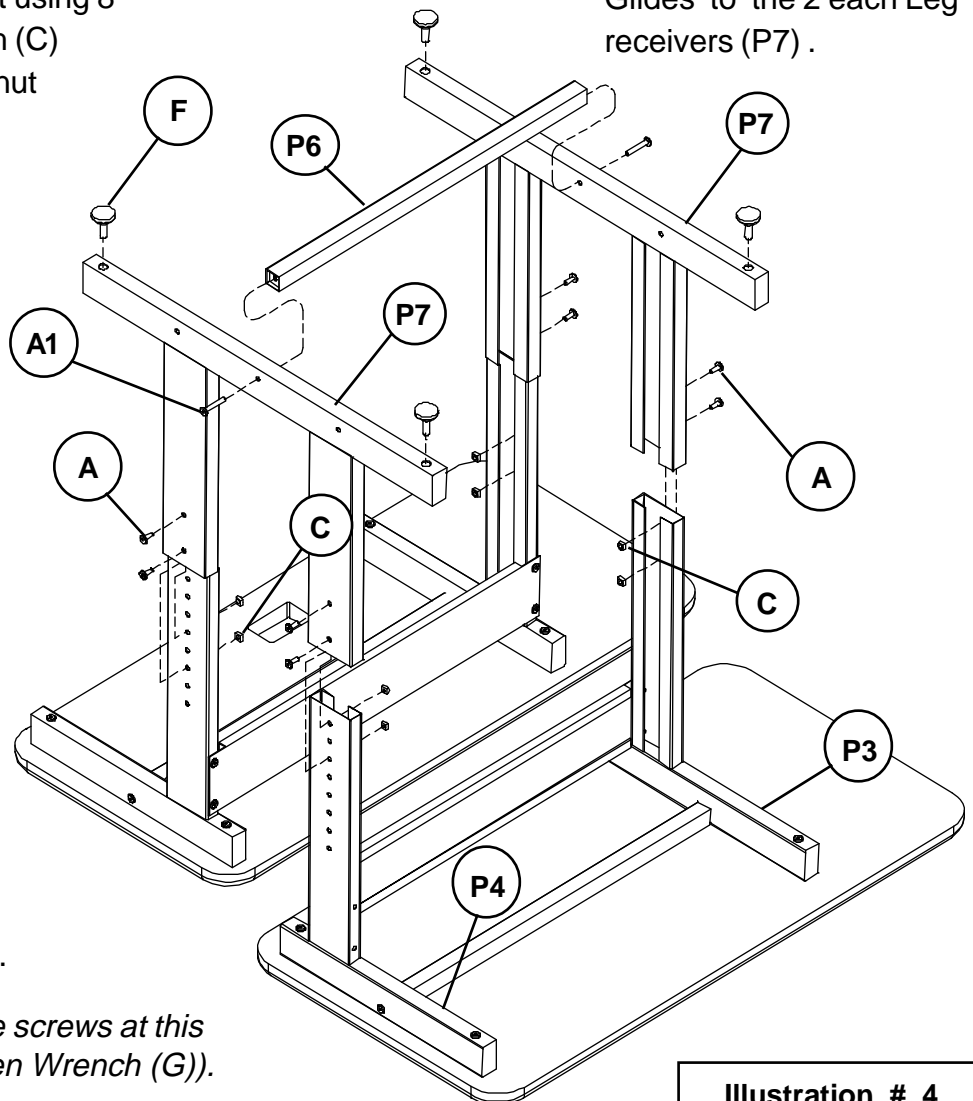

Illustration # 4

- 10.) Attach Crossbrace (P6) between Leg Receivers (P7) using 2 Screws (A1) as shown in illustration #4.

*(Tighten all the screws at this time using Allen Wrench (G)).*

11.) Place the CPU Platform (P10) with the insert nuts facing up. Attach 2 each CPU Feet (P9) using 4 each (A2) screws.  
***(Finger tighten only)***

12.) Attach 1 each CPU Rail (P8) to the CPU Platform (P10) using 2 each (A1) screws.  
***(Finger tighten only)***

13.) Attach 2 each Glides (F) to the 2 Feet (P9) as shown in illustration #5.

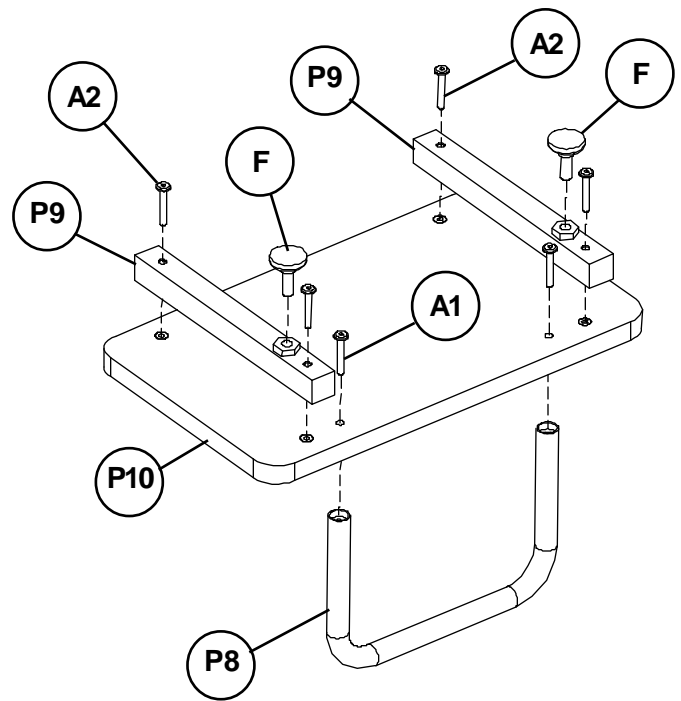

Illustration # 5

14.) Attach 1 each CPU Assembly to the outside of Leg Receiver (P7) using 2 Screws (A1) as shown in illustration #6.

***(Tighten all the screws at this time using Allen Wrench (G)).***

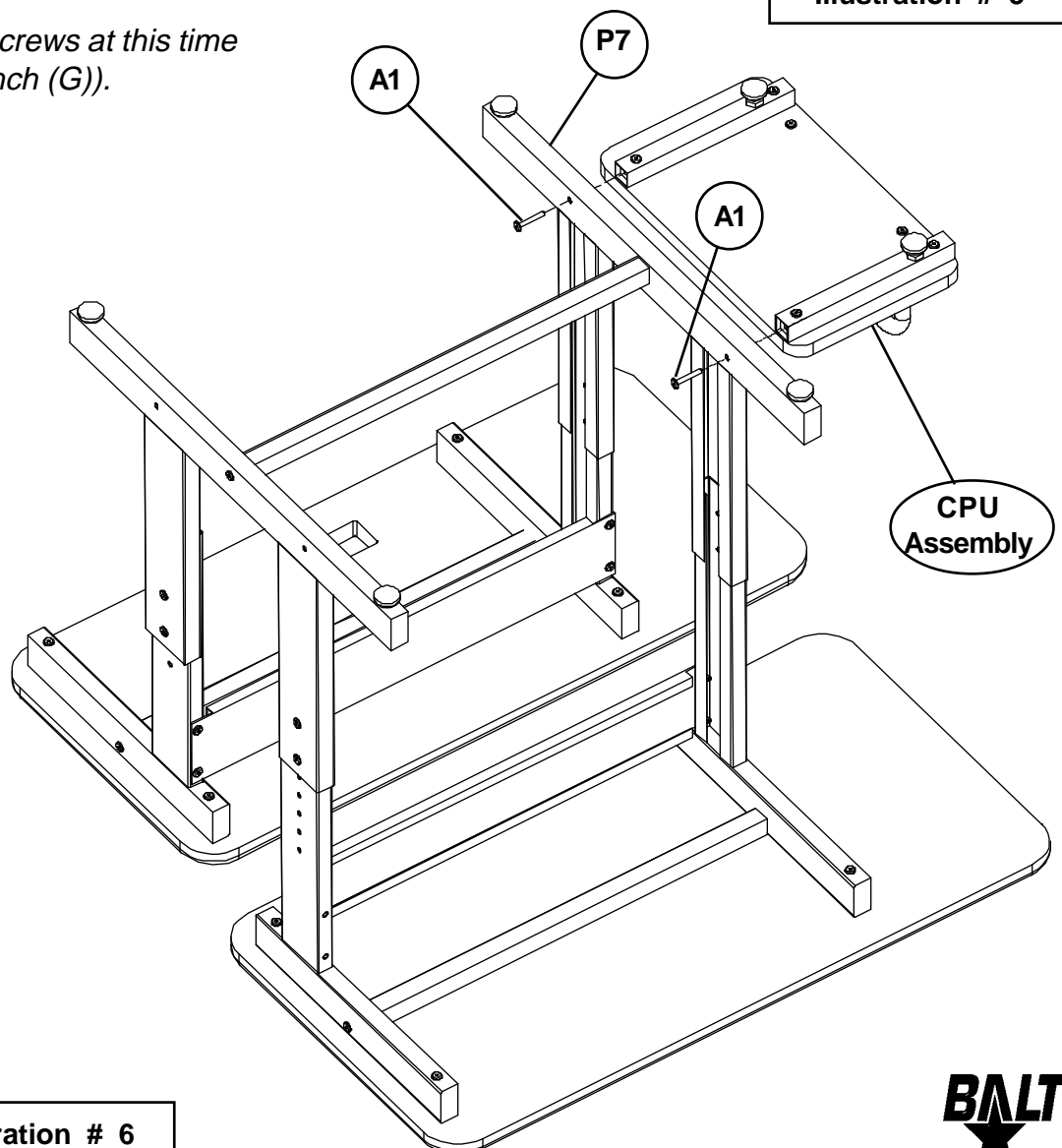
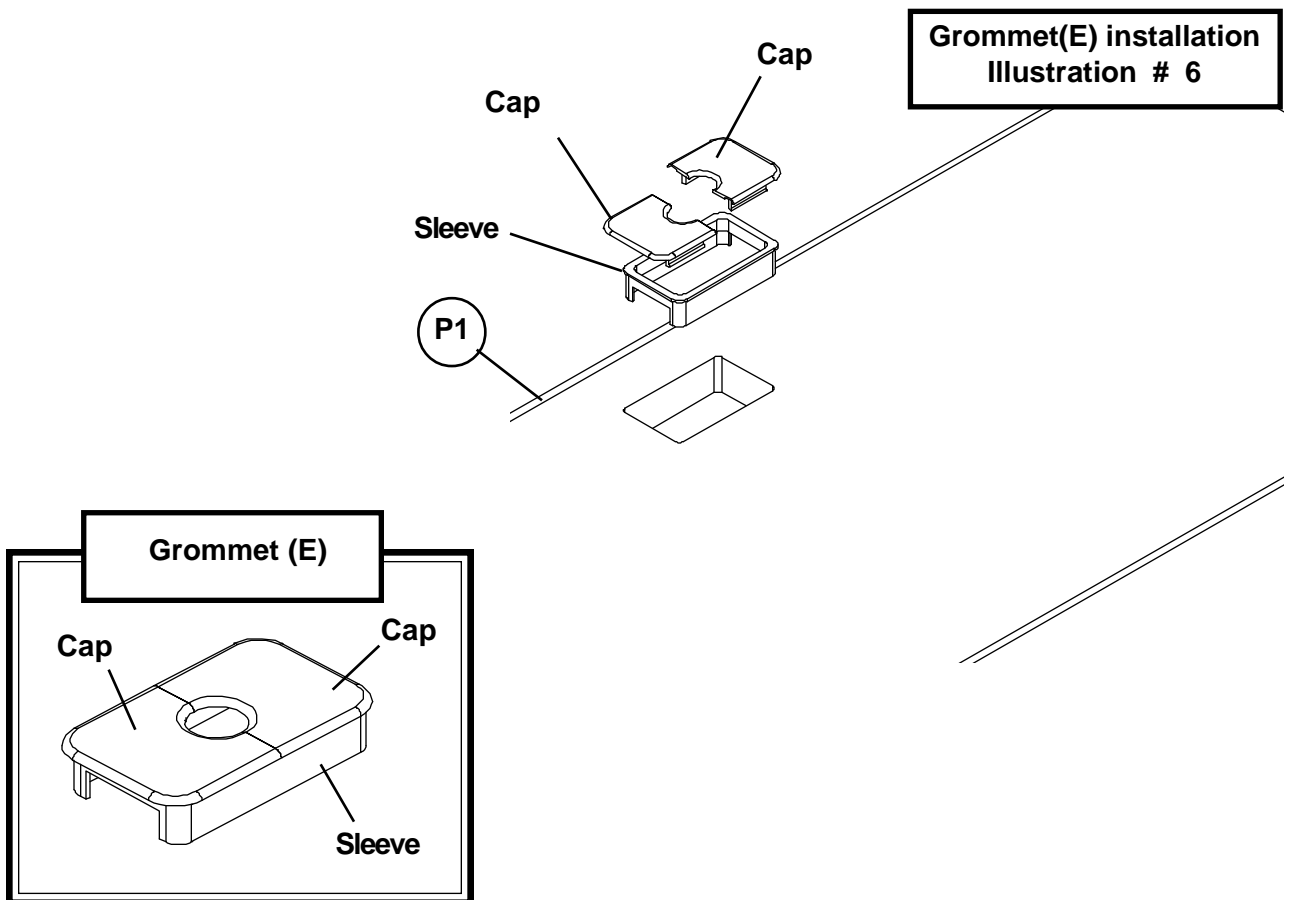

Illustration # 6



15.) To install Grommet (E), separate parts and press Grommet Sleeve in rectangular opening in Monitor Platform (P1) as shown in illustration #6.

Snap 2 plastic Caps over top of Sleeve as shown in illustration #6.



## Important

The Balt product you have purchased is guaranteed against material and workmanship defects. This guarantee extends 1 year from date of purchase. Should this product fail to function satisfactorily under normal use due to defect or imperfection, the defective part or product will be replaced. Damage caused by common carriers during shipment is not included in this guarantee.

**This guarantee sets forth all applicable guarantees and remedies. No other warranty, expressed or implied shall apply. Failure to follow instructions found in Important Information Section of Owner Sheet shall void the guarantee. Consequential or incidental damages and or costs are not refundable.**

# Split-Level-36 Task Table



For more information  
1-800-749-2258

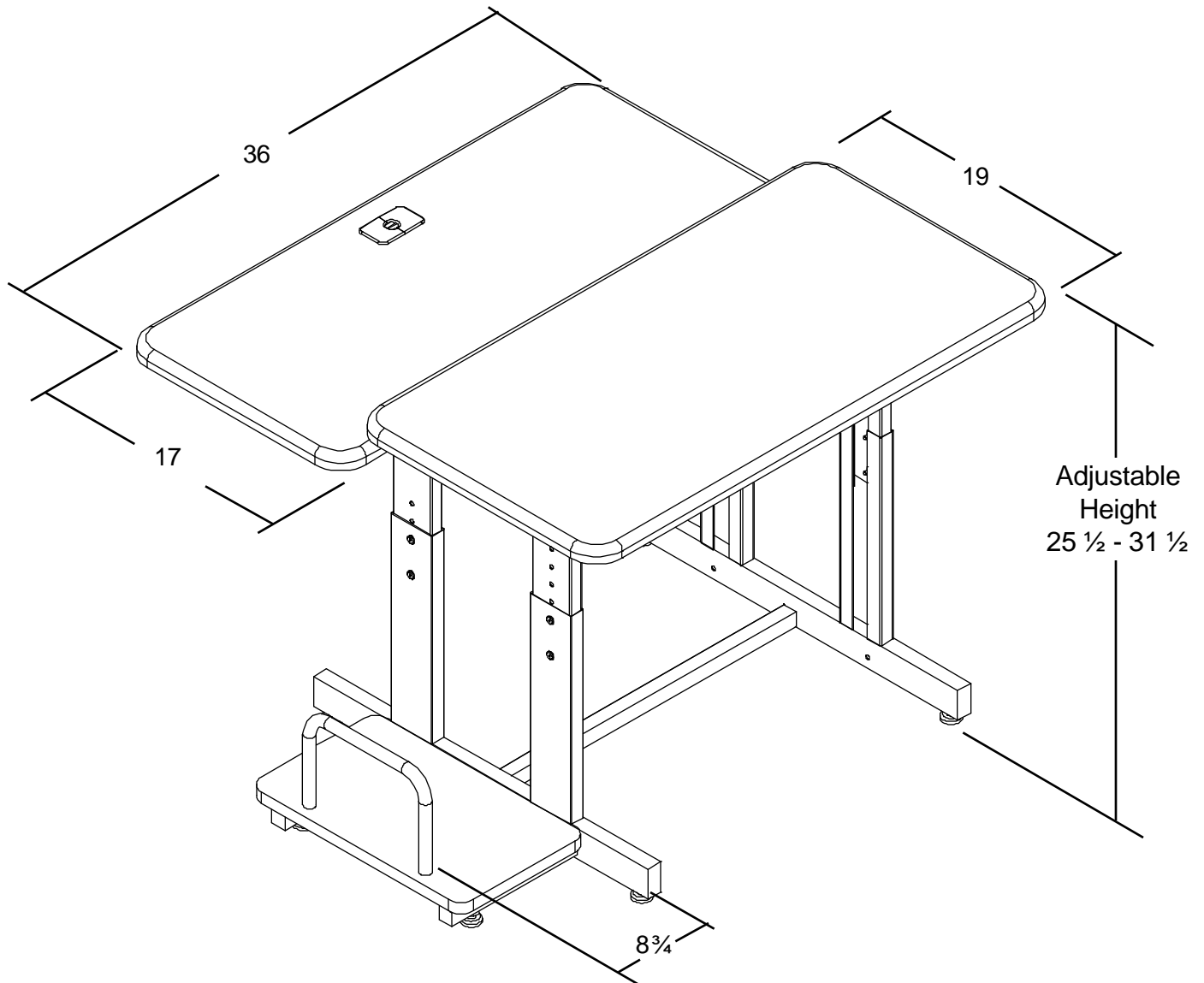

## Shipping Information

2.8 Cubic Feet  
35 lbs.

