

BALT®

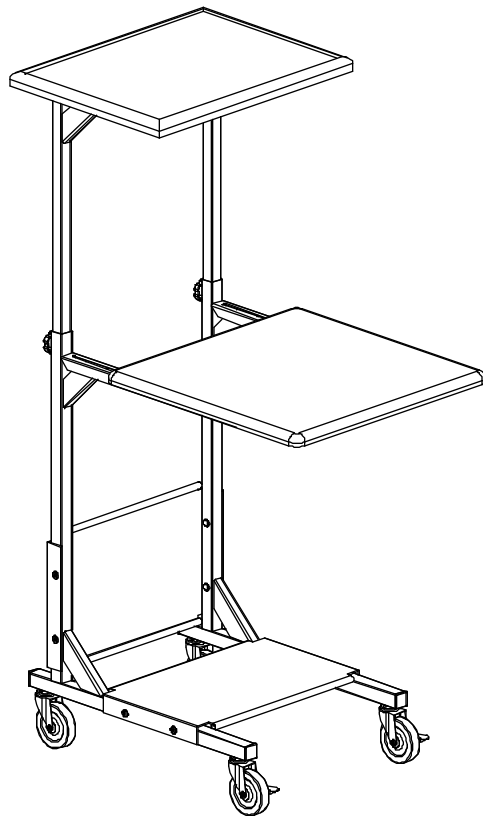







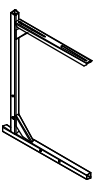
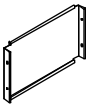

PBL Adjustable Height Presentation Stand

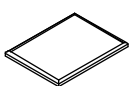

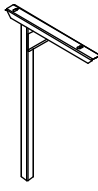
Assembly Instructions

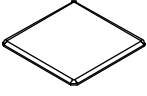
See back for important information

Adjustable Height Presentation Stand PBL

Part	Drawing	Description	Qty	Part	Drawing	Description	Qty
P-1		Leg Frame	2 EA	Hardware List			
P-2		Stability Panel	2 EA	A		Flat Head Screw	16 EA
P-3		Top Platform	1 EA	B		Interior Threaded Post	8 EA
P-4		Upper Insert	2 EA	C		3" Locking Casters (for Front)	2 EA
P-5		Laptop Platform	1 EA	D		3" Casters (for Back)	2 EA
Tools Required: Philips Head Screw Driver				E		Allen Wrench	1 EA
				F		Caster Wrench	1 EA
				G		Knob	2 EA

To Assemble:

1. Identify and Separate all the Parts and Hardware.
2. Place the Top Platform (P-3) with the insert nuts facing up. Attach 2 Upper Inserts (P-4) using 4 Flat Head screws (A) as shown in illustration # 1.

(Do not tighten the screws all the way).

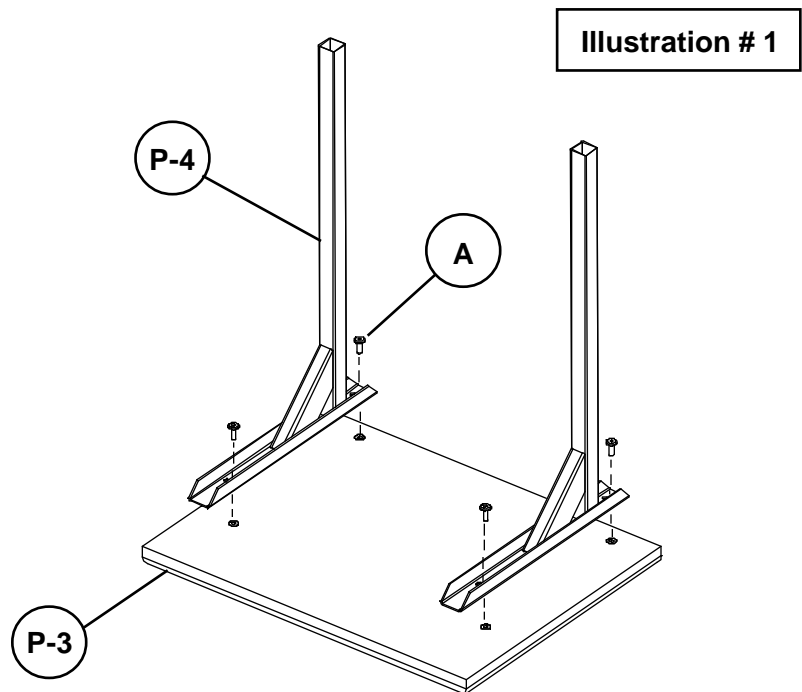

Do not use unless all screws are tight. At least every six months, check all screws to be sure they are tight. If parts are missing, broken, damaged, or worn, stop use of the product until repairs are made by your dealer using factory authorized parts.



PBL Adjustable Height Presentation Stand Assembly Diagram

Illustration # 2

3. Attach 2 Stability Panels (P-2) to 2 Leg Frames (P-1) using 8 Flat Head screws (A) and 8 Interior Threaded Posts (B) as shown in illustration # 2.

4. Attach 2 Locking casters (C) in the front and 2 Casters (D) in the back. Tighten the Casters using Caster Wrench (F)]

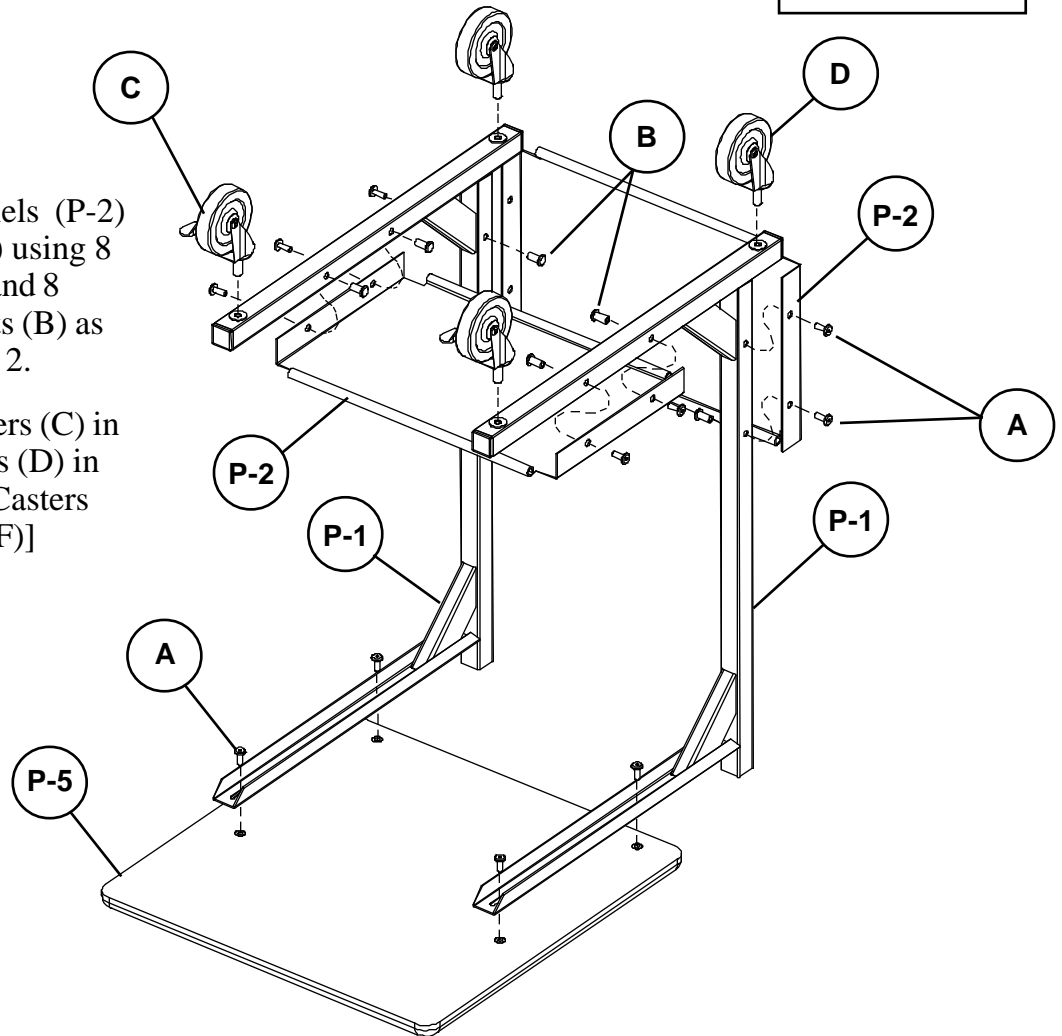

5. Attach Laptop Platform (P-5) to 2 Leg Frames (P-1) using 4 Flat Head screws (A).

Note: It is recommended that when attaching stability panels, loosely tighten until all four screws and thread posts are positioned before fully tightening with Allen Wrench.

- Slide the Top Assembly into the Leg Assembly and secure at desired height using 2 Knobs (G) as shown in illustration # 3.
- Tighten all screws securely using Allen Wrench (E).

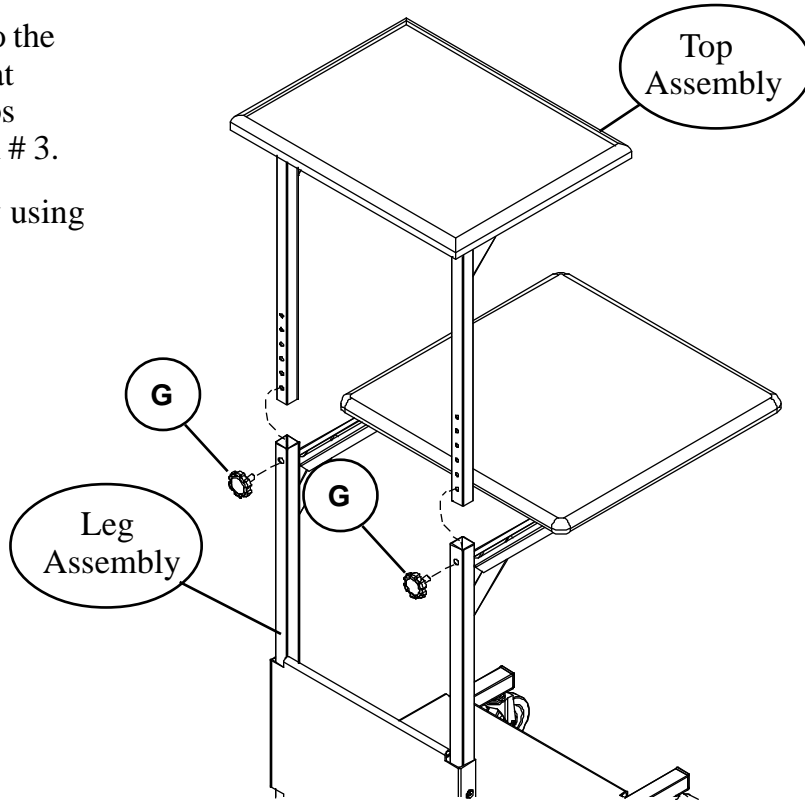

Important

The Balt product you have purchased is guaranteed against material and workmanship defects. This guarantee extends 1 year from date of purchase.

Should this product fail to function satisfactorily under normal use due to defect or imperfection, the defective part or product will be replaced. Damage caused by common carriers during shipment is not included in this guarantee.

This guarantee sets forth all applicable guarantees and remedies. No other warranty, expressed or implied shall apply. Failure to follow instructions found in Important Information Section of Owner Sheet shall void the guarantee. Consequential or incidental damages and or costs are not refundable.

Toll-Free Customer Service
1-800-749-2258

*Should you require assistance during assembly,
please call our Customer Service Department
Monday - Friday 8 a.m. - 5 p.m.
Central Standard Time*