

# MA-3-C Monitor Arm

## COMPLETED ASSEMBLY

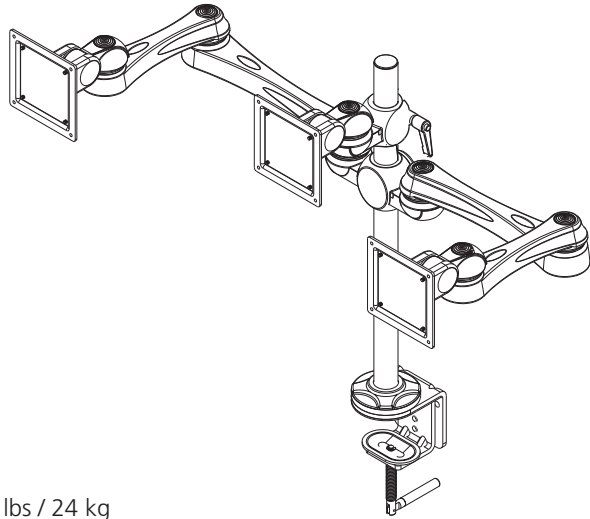

Loading up to 53 lbs / 24 kg

## STEP 1 Join the Arm Components Together

Use the hardware supplied to attach together the following components:

- LA-511 Vesa (3)
- LA-512 Short Arm (2)
- LA-513 Long Arm (2)
- LA-514 Connector (1)

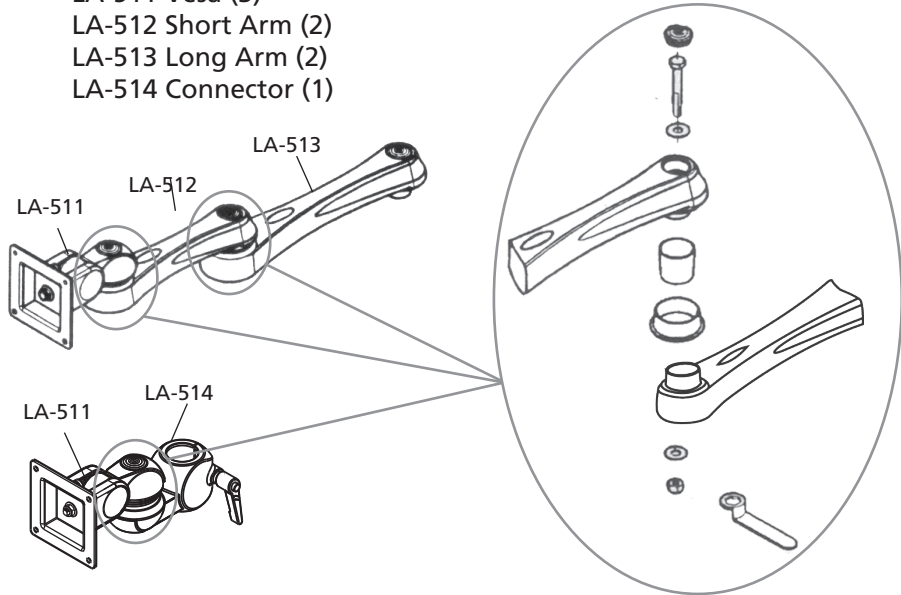

# Assembly Guide

## STEP 2 Mount the Clamp to the Worksurface

Use the hardware supplied to attach the LA-201 clamp to the worksurface. Then attach the LA-501A pole to the LA-201 clamp.

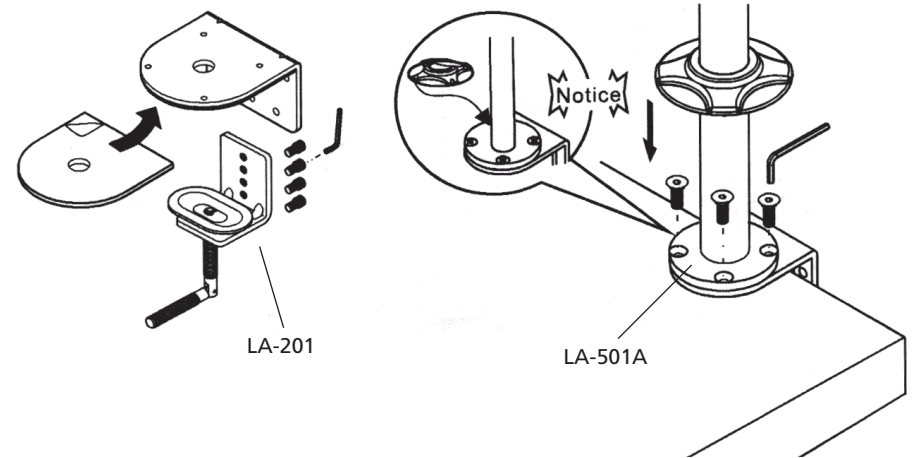

## STEP 3 Mount the Monitor Arm to the Monitor

Place monitor face down on a flat surface. Place LA-511 Vesa on the back of the monitor and secure with screws supplied.

**75mmx75mm VESA interface.**

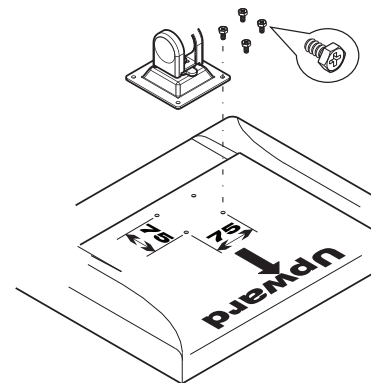

**100mmx100mm VESA interface.**

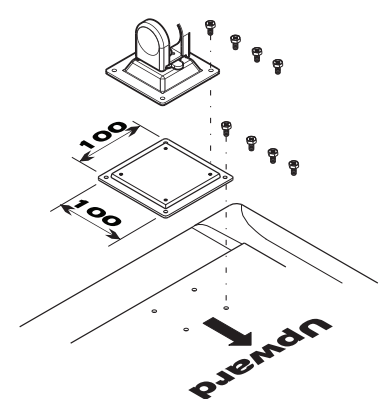

## Assembly Guide

### STEP 4

Loosen the two screws slightly on the LA-515 connector. Place the connector on the pole at the desired viewing height. Tighten up the screws.

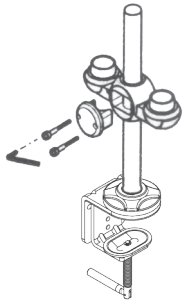

### STEP 5

Carefully support the monitor and place long arm on the connector and then secure using the hardware supplied. Repeat for the other long arm.

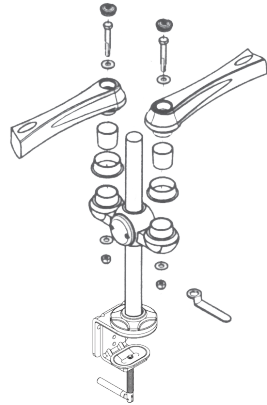

### STEP 6

Place the joint arm (with monitor attached) on the pole. Use the lever to tighten, or secure with supplied screw. Insert pole cap into pole.

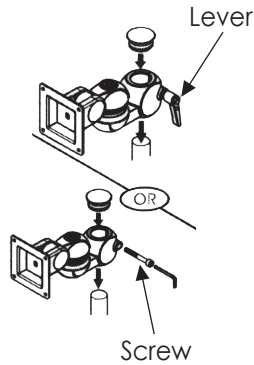

### STEP 7

#### Adjusting Swivel Tension

Use the wrench to tighten or loosen the arm. Screw on the cable holders.

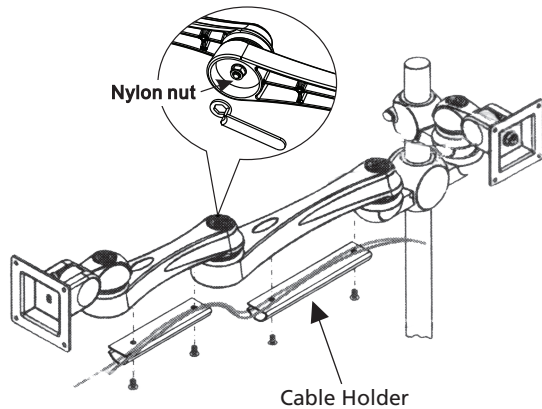

## Assembly Guide

### STEP 8

#### Adjusting Vesa Tension

When assembling the arm with monitors of differing weights, you may find that the tension of the vesa needs to be adjusted to maintain the desired monitor position. If so, adjust as follows:

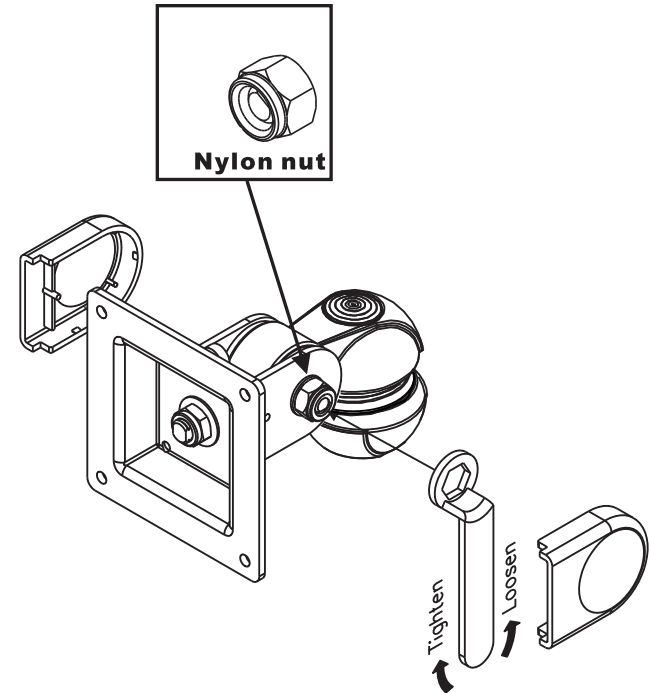

- Remove the two plastic vesa joint covers
- Find the nylon nut (not the screw head) and use the included wrench to adjust the tension.
- Use one hand to support the monitor and adjust the tension of the vesa.
  - Clockwise: more tension
  - Counterclockwise: less tension
- When the desired tension is achieved, replace the two plastic covers.

#### Caution:

- Support the monitor during the adjustment procedure.
- Only adjust the nylon nut (not the screw head).
- Do not disassemble the vesa.