

TECHNICAL DATA SHEET - Projector Enclosure



MODELS: PE 1120, PE 1120-W

Lock in the highest level of security with the **PE 1120**. Solid 1/2" diameter steel bars provide protection from theft or accidental damage. Installation is a snap – just snap the two halves of the steel frame together and hook the enclosure body to the frame. It's so easy that you can attach it to existing projector installations without having to remove the projector mount or disturbing the image alignment settings. It's the toughest security available with a user-friendly design.

Features:

- Colors: White or black
- Secures any projector and mount with an all-steel enclosure and solid steel bars
- Retrofittable without tampering with existing installations
- Attaches to 1"-1.5" NPT pipe or can be attached directly to a structural or suspended ceiling
- Easy three step installation
- Hook-n-Hang frame design for fast maintenance access
- Adjustable bars to accommodate the projector lense placement
- Patented security fasteners and security wrench only offered by Peerless
- Padlock ready

Dimensions :

Weight:

35.4 lbs. (16.1 kg)

Shipping weight:

44 lbs. (20 kg.)

Shipping Carton dimensions:

L= 26.75 in (679 mm)

W= 23.75 in (603 mm)

H= 16 in (406 mm)

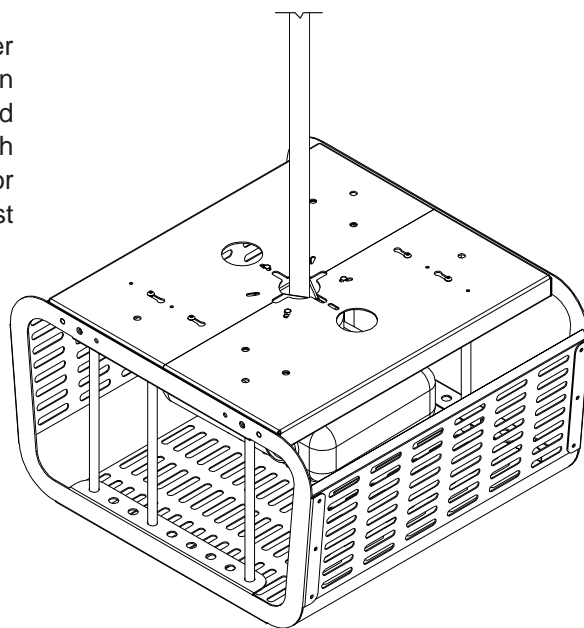

ARCHITECTS SPECIFICATIONS

The **Projector Enclosure** shall be a Peerless model _____ and shall be located where indicated on the plans. It shall be constructed of steel and finished in black or white fused epoxy. Assembly and installation shall be done according to instructions provided by the manufacturer.

Peerless Industries, Inc.

3215 W. North Ave. Melrose Park, IL 60160
708-865-8870 800-865-2112 Fax 708-865-2941

www.peerlessmounts.com

ISSUED: 05-18-06 SHEET NO: 056-9583-1

©2006 Peerless Industries, Inc. All rights reserved.
Peerless is a registered trademark of Peerless Industries, Inc.

All other brand and product names are trademarks or registered trademarks of their respective owners.

TECHNICAL DATA SHEET

MODELS: PE 1120, PE 1120-W

ALL DIMENSION = INCH
(MM)

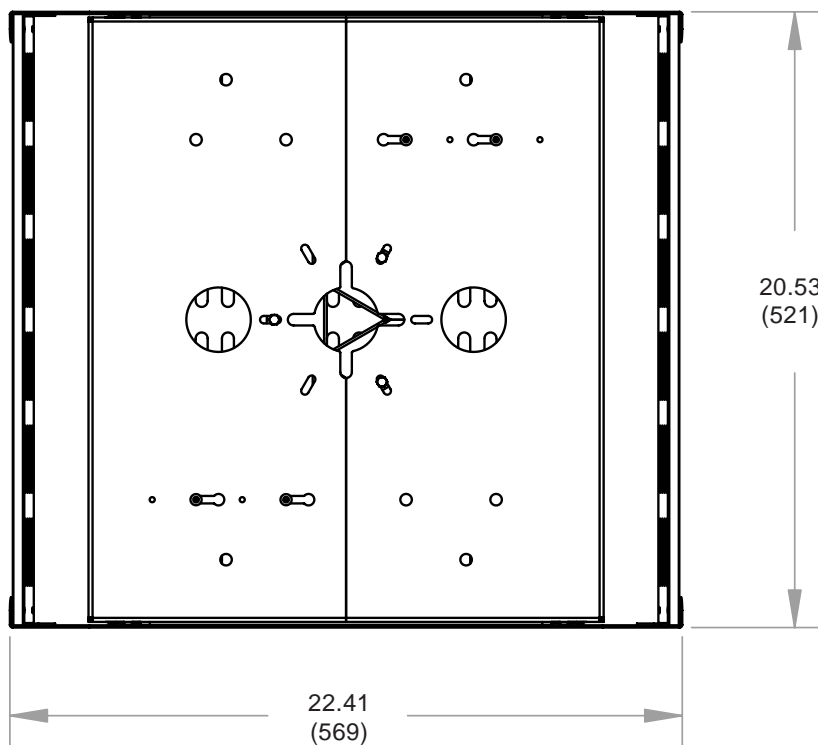

Top View

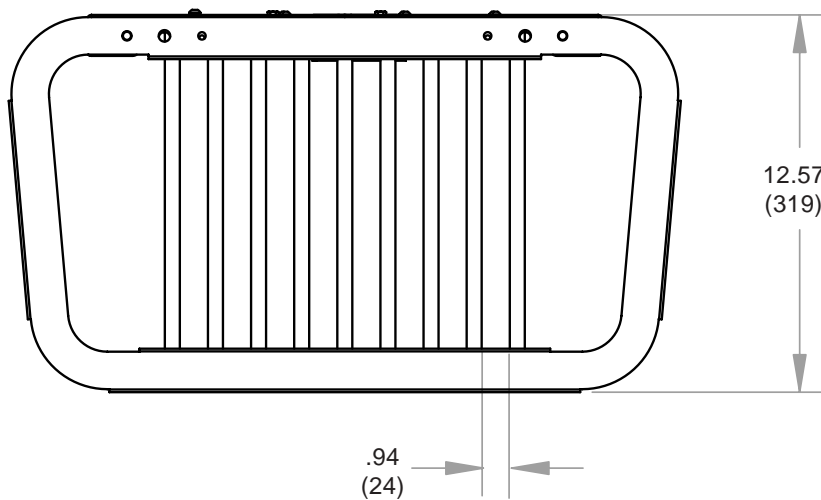

Front View