

TECHNICAL DATA SHEET - Universal Projector Security Mount



MODEL: PSM-UNV, PSM-UNV-S, PSM-UNV-W



Designed with security in mind, the PSM-UNV offers dual layers of protection for multimedia projectors. Security fasteners secure the projector to the mount, while the low-profile key-locking tray protects these fasteners for an extra level of security. The PSM-UNV features a standard adjustment screw that makes it easy to position the projector without having to compromise or access secure components. This sleek yet solid security tray comes complete with the mount, extension column connector and cable management system that keeps cords out of sight. The PSM-UNV combines security with easy to install and use design that is uniquely Peerless.

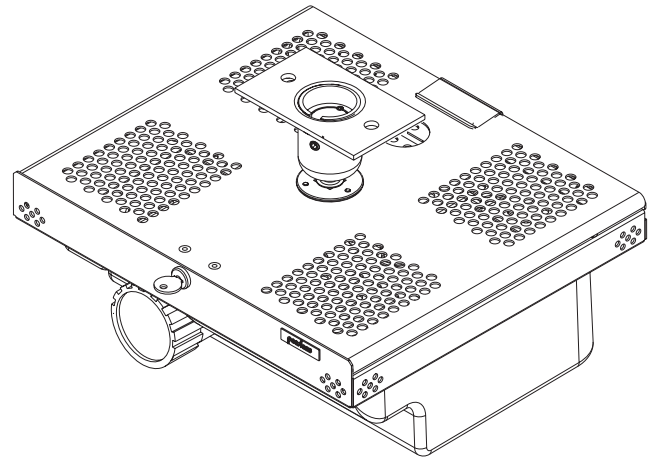

Features:

- Dual-levels of security for added theft-deterrence
- Universal tray pattern accommodates most projectors
- Built-in mount aligns image with single adjustment point
- Multiple access holes for versatile cable management
- Easy projector access without compromising mount security
- Available in black, silver or white finish to match projector or décor
- Single adjustment point for quick projector alignment
- Tilt 30° ($\pm 15^\circ$), Roll 30° ($\pm 15^\circ$), Swivel 360°
- Easy cable management access
- Ceiling plate included with mount
- Security fasteners at every connection point
- Threads directly into any ceiling plate that accepts standard 1.5" NPT schedule 40 pipe
- Hinged two-piece tray with slide-out feature enables quick disconnect for projector maintenance

Dimensions:

For product dimensions, see pages 2 - 4.

Accessories:

- Ceiling plates (various models available)
- Fixed and adjustable length extension columns
- Cord wrap
- Suspended ceiling kits
- Anti-vibration and stabilizer accessories

ARCHITECTS SPECIFICATIONS:

The projector mount shall be a Peerless Model **PSM-UNV** and shall be mounted where indicated on the plans. It shall feature 30° ($\pm 15^\circ$) pitch, 30° ($\pm 15^\circ$) roll, and 360° yaw. It shall have a 30 lb load capacity. It shall have a quick release slide out bottom tray for easy removal and installation and maintenance of the projector. It shall feature security screws. It shall be constructed of aluminum and steel finished in black, silver, and white. The tilting mechanism is constructed of aluminum. The main body of the mount shall be 16 gage cold rolled steel which locks into the tilting mechanism and is secured to the aluminum ball joint with a 1/4-20 x 1 1/2" long steel bolt. It shall be capable of holding up to 30 lb at the maximum 15° roll or pitch. Installation and assembly shall be done in accordance with the instructions provided by the manufacturer.

MODEL: PSM-UNV, PSM-UNV-S, PSM-UNV-W

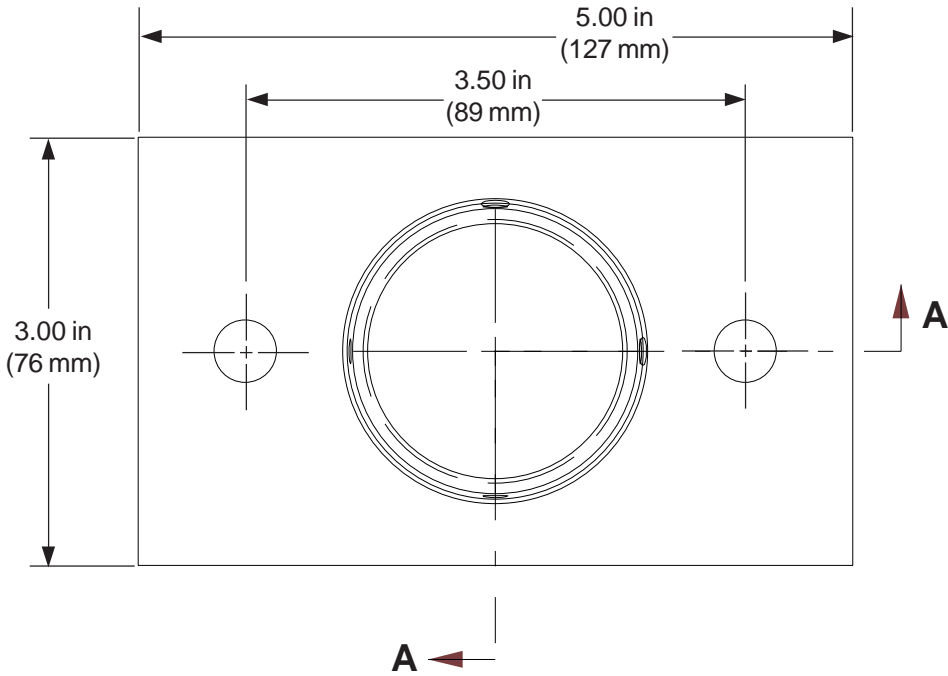

TOP VIEW
(CEILING PLATE DETAIL)

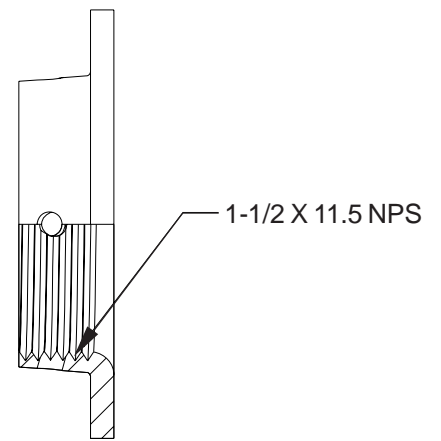

SECTION A-A

MODEL: PSM-UNV, PSM-UNV-S, PSM-UNV-W

Security Features

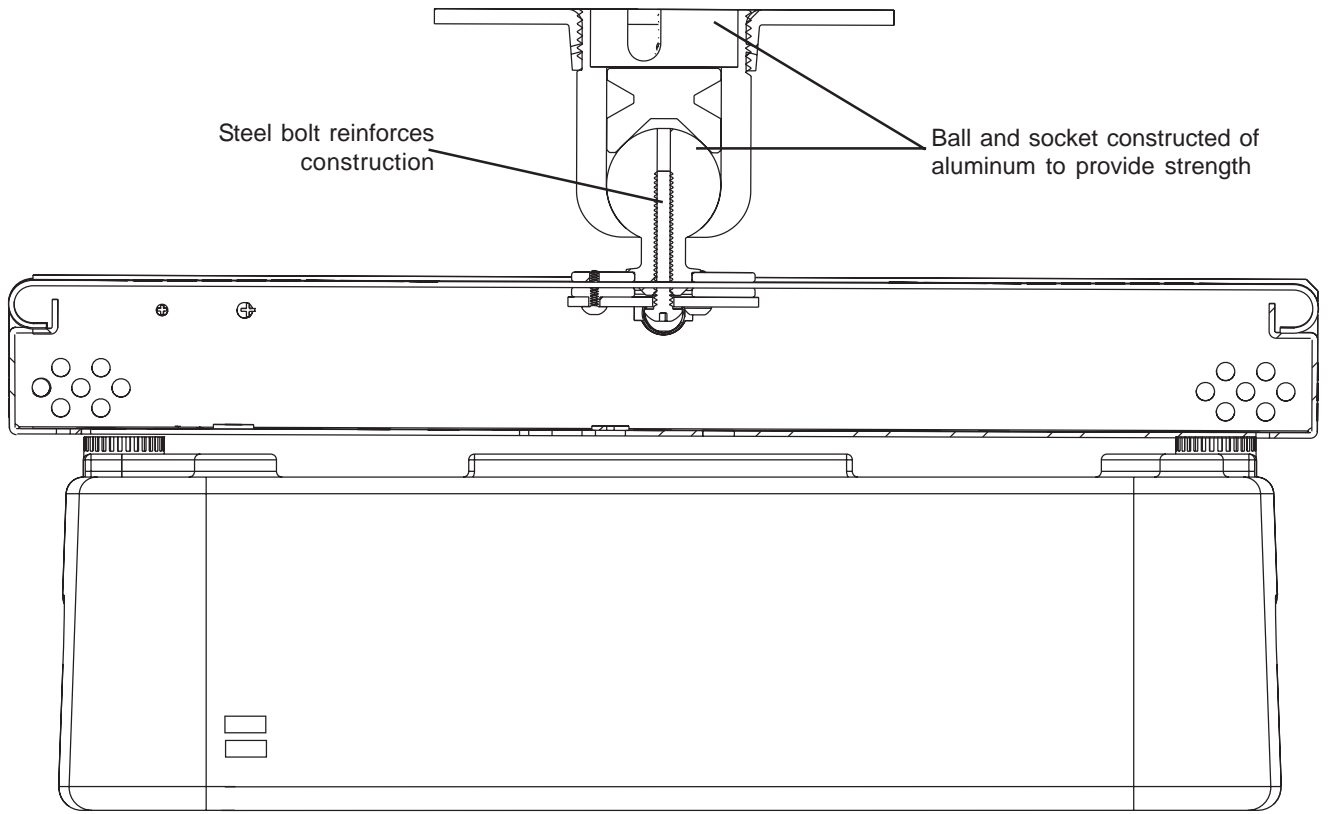

CUT AWAY VIEW

TECHNICAL DATA SHEET

MODEL: PSM-UNV, PSM-UNV-S, PSM-UNV-W

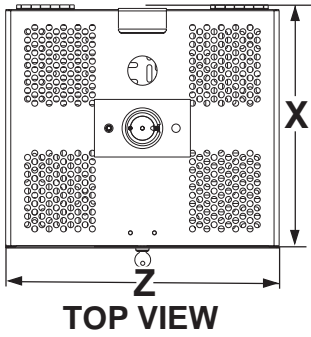

| MODEL# | COLOR | CARTON DIMENSIONS | SHIPPING WEIGHT | PRODUCT WEIGHT | DIMENSIONS | | | MAX LOAD CAPACITY |
|-----------|--------|---|-----------------|----------------|----------------|---------------|----------------|-------------------|
| | | | | | X | Y | Z | |
| PSM-UNV | Black | 15.13 x 15.13 x 7.13 (384 x 384 x 181) | 10.7 (4.7) | 8.8 (4.0) | 12.82 (326) | 4.67 (119) | 14.25 (362) | 30 (14) |
| PSM-UNV-S | Silver | 15.13 x 15.13 x 7.13 (384 x 384 x 181) | 10.7 (4.7) | 8.8 (4.0) | 12.82 (326) | 4.67 (119) | 14.25 (362) | 30 (14) |
| PSM-UNV-W | White | 15.13 x 15.13 x 7.13 (384 x 384 x 181) | 10.7 (4.7) | 8.8 (4.0) | 12.82 (326) | 4.67 (119) | 14.25 (362) | 30 (14) |

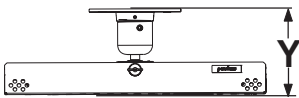

All dimensions shown above as in / (mm). All weights shown as lb / (kg).
 Note: Y is the dimension from the top of the ceiling plate to the projector mount interface.

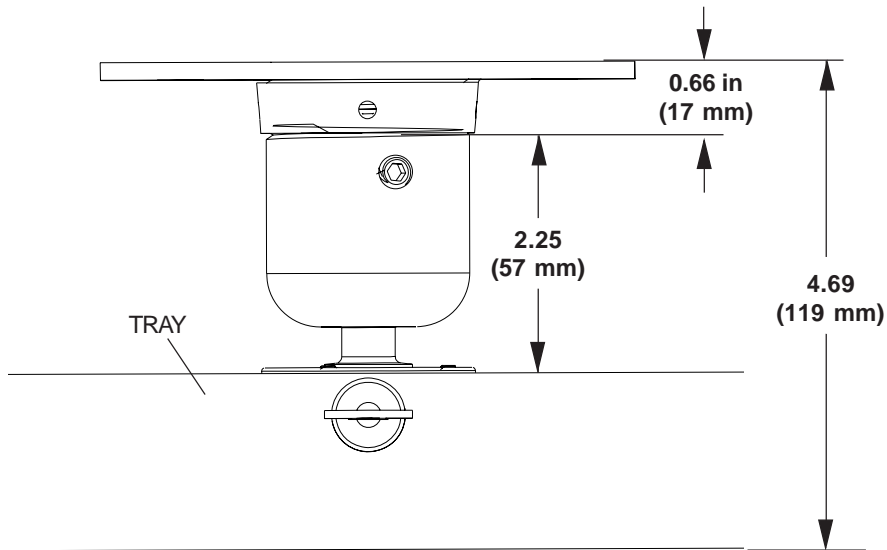

30° (±15°) ROLL

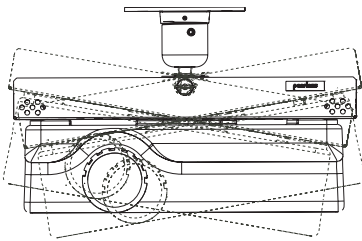

30° (±15°) PITCH

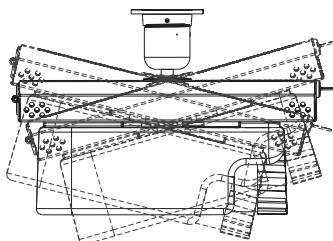

360° (±180°) YAW

