

## Installation and Assembly: Jumbo™ Adjustable Height TV/Projector Cart

---

**Models:** JCT 2642, JCT 2642E

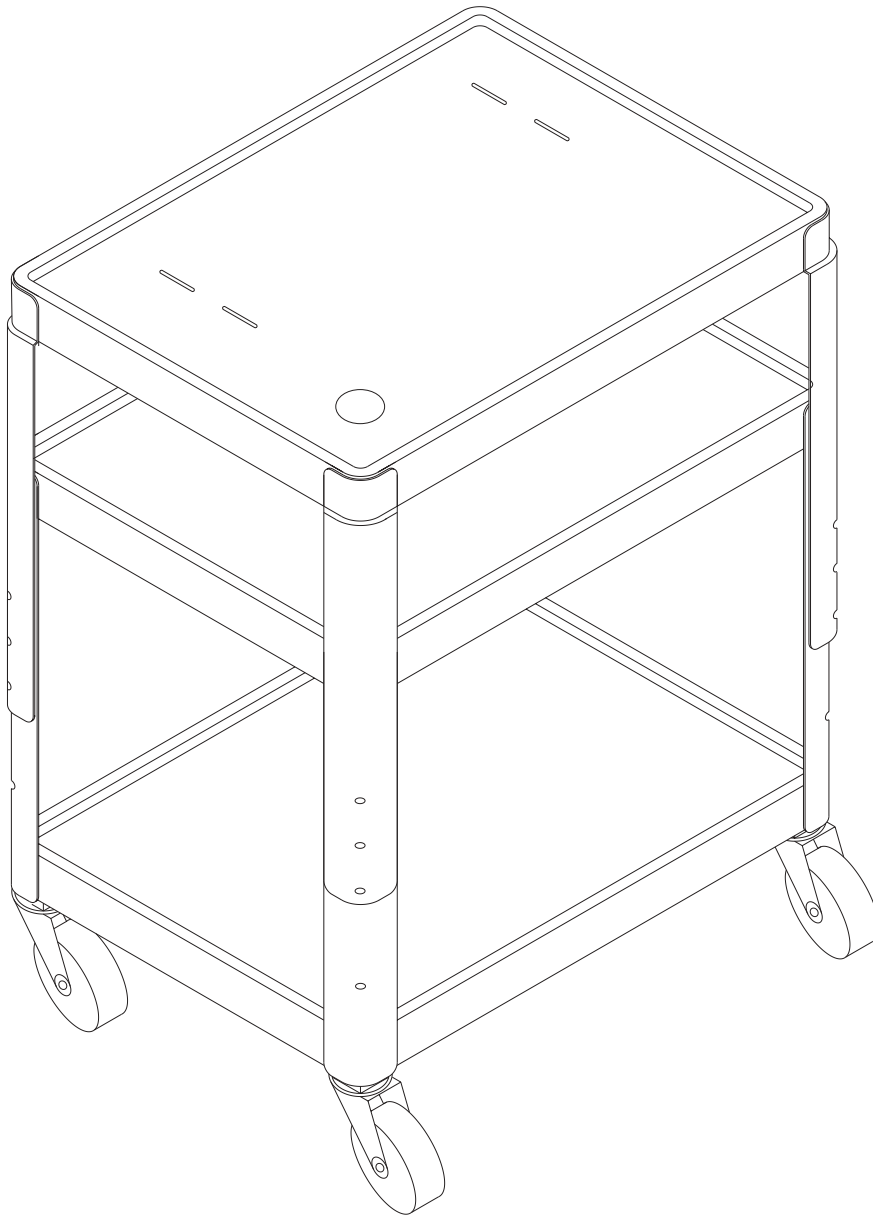

Max Load Capacity: 200 lb (90.7 kg)

**Note:** Read entire instruction sheet before you start installation and assembly.

## ⚠ WARNING

- Do not begin to install your Peerless product until you have read and understood the instructions and warnings contained in this Installation Sheet. If you have any questions regarding any of the instructions or warnings, please call Peerless customer service at 1-800-729-0307.
- This product should only be installed by a qualified professional.
- Unit should be moved by authorized adults only.
- Prior to moving tables, place all AV equipment materials on lowest shelf possible. Secure heavy or bulky equipment to table with safety belts.
- Disconnect all electrical cords from wall outlets and secure to equipment on table.
- Unlock all casters, push mobile table from the narrow side of unit only. Never pull.
- Avoid rough or uneven flooring and remove any obstacles in your path.
- Apply force to the narrow side. Do not pull the unit.
- When set up for stationary use or when loading or unloading equipment, books, etc., always secure the casters before doing so.
- When using the table as an equipment stand, the equipment should be put on the lowest possible shelf that will still allow the equipment to operate correctly. The equipment should be placed in the center of the shelf it is sitting on.
- The product should not be used as a stool or a ladder.

## Parts List

Description	Qty.	Part #
<b>A</b> top shelf section (24" x 18")	1	009-1037
<b>B</b> bottom shelf section (24" x 18")	1	009-1038
<b>C</b> large phillips head bolts	4	520-1177
<b>D</b> hex nuts	4	530-1014
<b>E</b> 4" casters without brakes (not shown)	2	560-0082
<b>F</b> 4" casters with brakes (not shown)	2	560-0083
<b>G</b> rubber mat	1	009-1045
<b>H</b> cord wrap clip (JCT 2642E only)	1	009-1168
<b>I</b> 15' extension cord (JCT 2642E only)	1	600-1011
<b>J</b> small phillips head bolts (JCT 2642E only)	2	520-1219
<b>K</b> wingnuts (JCT 2642E only)	2	530-1025

Some parts may appear slightly different than illustrated.

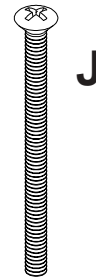
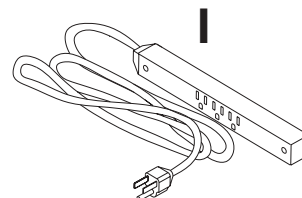
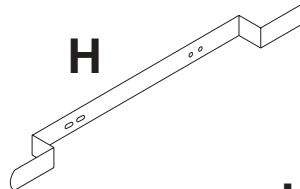
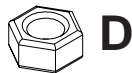
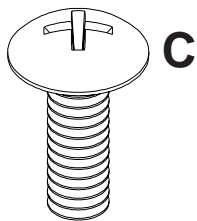
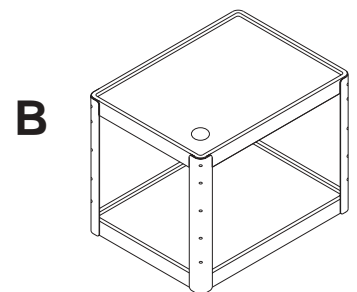
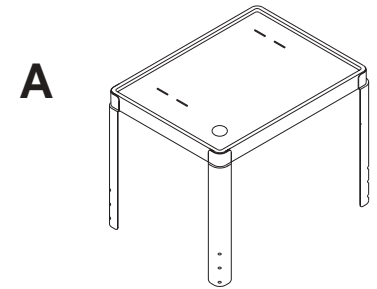

**1** Slide top shelf (A) onto bottom shelf (B).

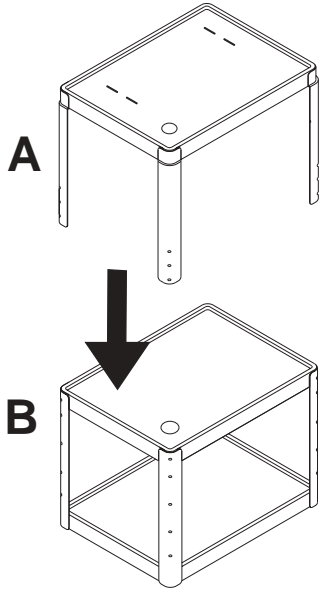

**2** Align corresponding holes of units to obtain desired height of table per illustration and legend below.

Desired Unit Height	Use These Corresponding Holes
25"	1 & EE
27"	2 & EE
30"	3 & EE
28"	1 & DD
32"	3 & DD
34"	2 & CC
36"	3 & CC
38"	2 & BB
40"	3 & BB
42"	3 & AA

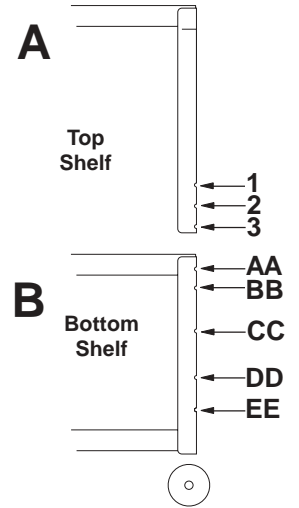

**3** Insert one bolt (C) and nut (D) into each leg of table. Tighten all bolts (C) and nuts (D).

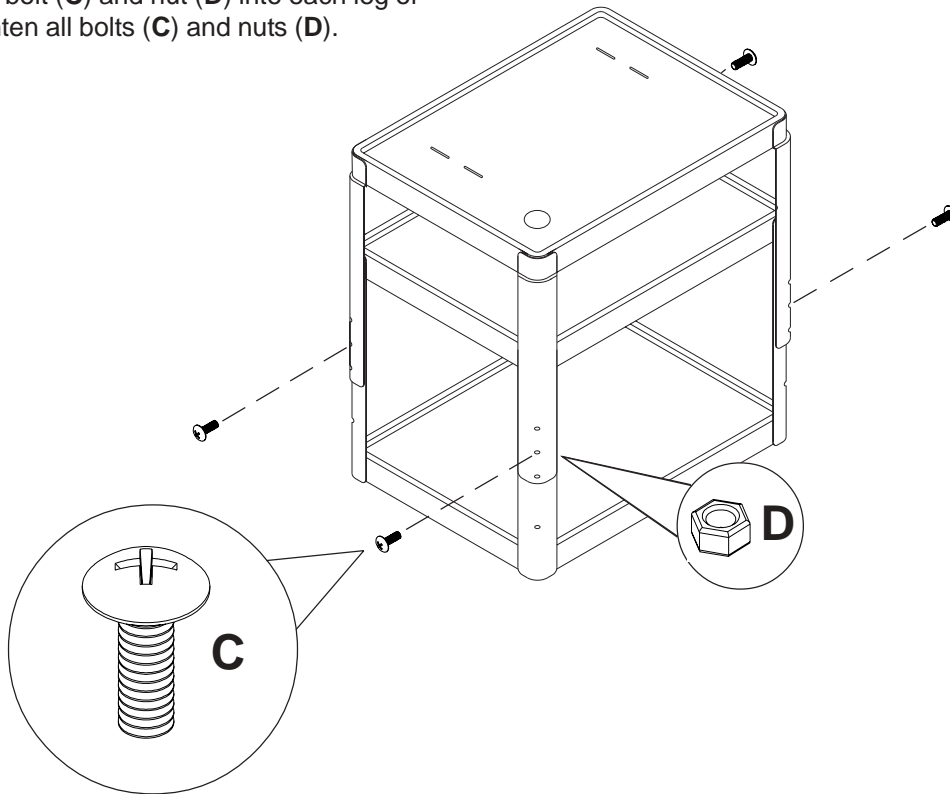

- 4** Lay unit upside down on floor. Insert caster with brakes (F) in two adjacent corner holes in the bottom of the unit. Insert other casters (E) into remaining holes of unit.

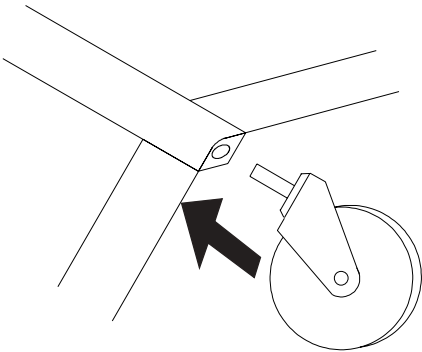

- 5** Stand unit onto casters and lay rubber mat (G) into desired shelf. Ribbed side of mat (G) should be upward.

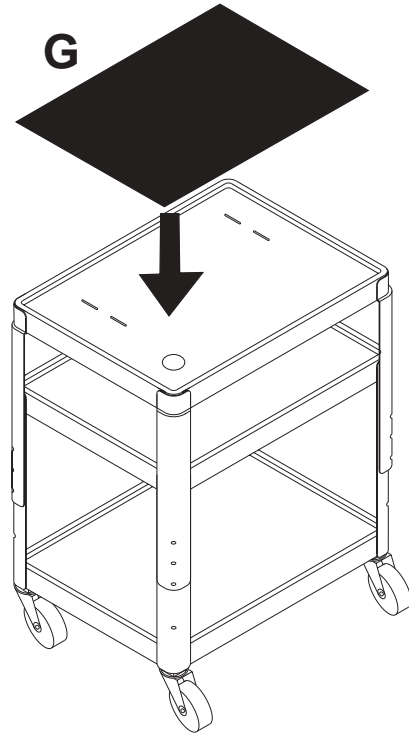

**This Step is for model JCT 2642E only!**

- 6** Fasten cord wrap clip (H) and extension cord (I) to desired shelf using two screws (J) and two wing nuts (K) as shown.

