

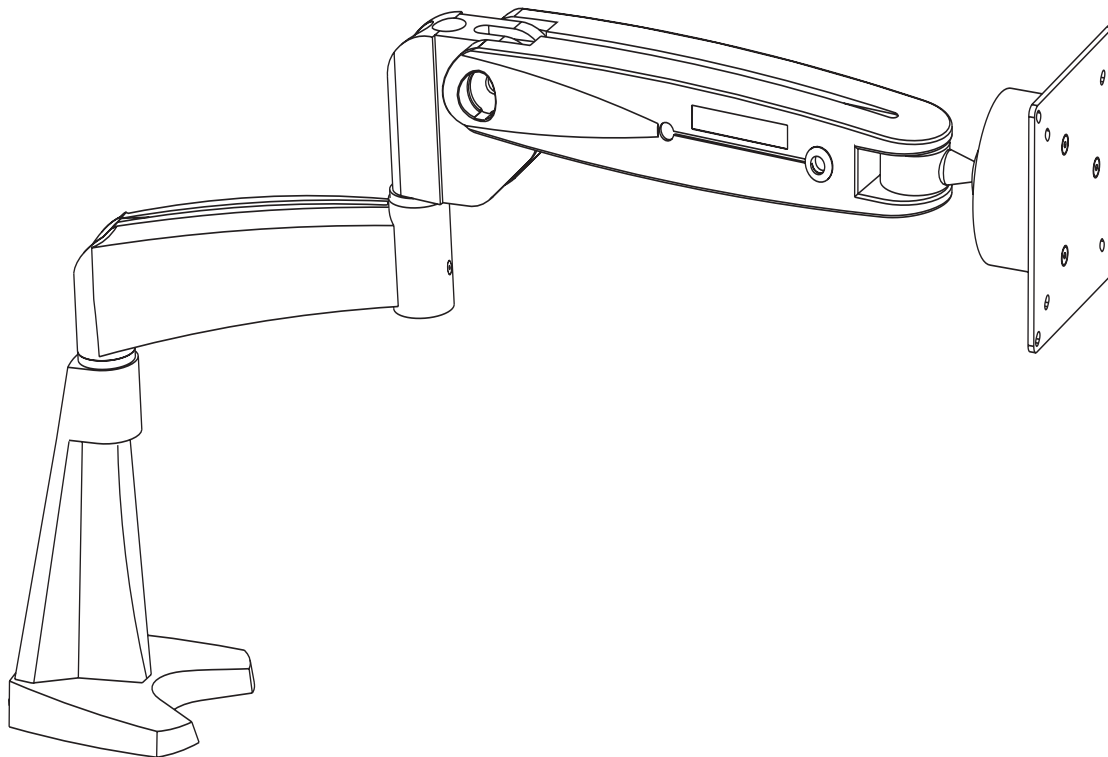

Installation and Assembly:
LCT Series LCD Arm

Model: LCT 101



Max Load Capacity: 25 lbs (11kg)

Note: Read entire instruction sheet before you start installation and assembly.

WARNING

- Do not begin to install your Peerless product until you have read and understood the instructions and warnings contained in this Installation Sheet. If you have any questions regarding any of the instructions or warnings, please call Peerless customer service at 1-800-729-0307.
- Make sure that the desk will safely support the combined load of the equipment and all attached hardware and components.
- Never exceed the Maximum Load Capacity of 25 lb (11 kg).
- Always use an assistant or mechanical lifting equipment to safely lift and position equipment.
- Tighten screws firmly, but do not overtighten. Overtightening can damage the items, greatly reducing their holding power.
- For safety reasons, the gas strut of the LCD Arm product was pre-adjusted in the factory to a lowest force for the prevention of arm body recoil during installation.
- During the installation, beware of the arm body recoil when attaching or detaching the LCD monitor to the LCD Arm. When changing LCD panels in the LCD Arm, please always readjust the gas strut to a lowest force level to control the recoil of the arm body. The LCD arm gas strut has been adjusted with the reserved force to load the original LCD panel, and the LCD Arm body will be recoiled when detaching the LCD panel directly without adjusting the gas strut.
- Do not attempt to disassemble, service or modify the product yourself.
- Use only a slightly damp cloth to clean the Arm surface. Never use flammable solvents like alcohol, benzene, thinner, etc.

Table of Contents

Parts List	3
Installation to desk with clamp option	4
Installation to desk with bolt option	4
Installing without extension arm	5
Installing extension arm	5
Monitor Attachment	6
Cable Management	7
Adjustment	7

For customer service call (800) 729-0307 or (708) 865-8870.

Parts List

	Description	Qty.
A	desk base assembly	1
B	arm assembly	1
C	plastic cap	1
D	plastic spacer	1
E	round head cap screw	1
F	M8 washer	1
G	M8 disk spring washer	1
H	set screw	1
I	M5 hex wrench	1
J	M2.5 hex wrench	1
P	base cushion with double sided adhesive	1
Q	u-bracket	1
R	M8 threaded rod	1
S	wing nut	1
T	M4 hex wrench	1
U	M4 x 6 mm screw	4
V	M4 x 10 mm screw	4
W	M3 screws	2
X	cable clip	1

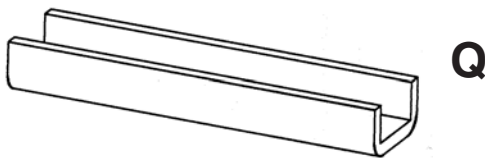
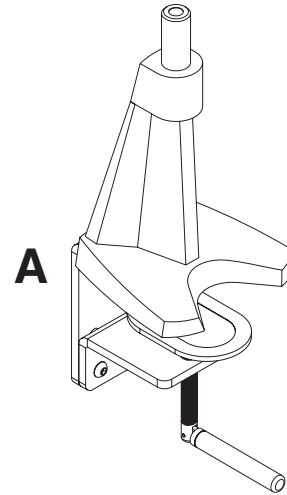
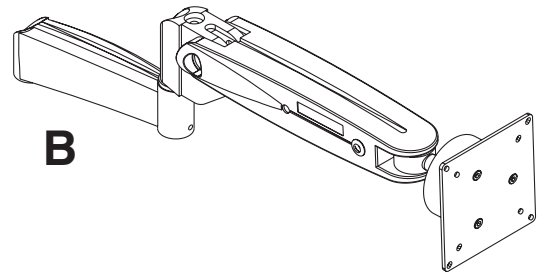

R



X

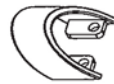

H



E

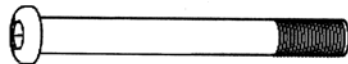

F



P

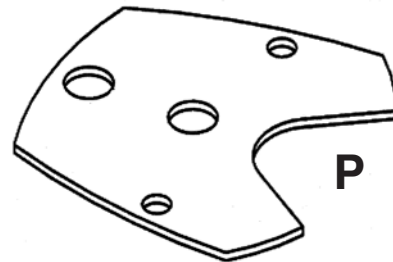

D

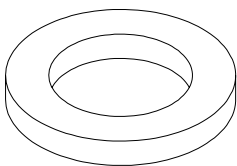

S

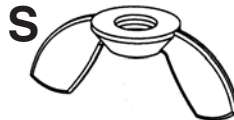

T



U



V

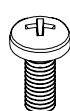

I



C

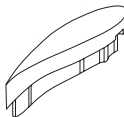

J



G

Installation to Desk

⚠ WARNING

- Make sure that the supporting surface will safely support the combined load of the equipment and all attached hardware and components.

Installation to desk with clamp option

- 1 Attach base cushion (P) to desk base assembly (A) by the double sided adhesive tape as shown below. Clamp desk base assembly to desk by tightening down clamp.

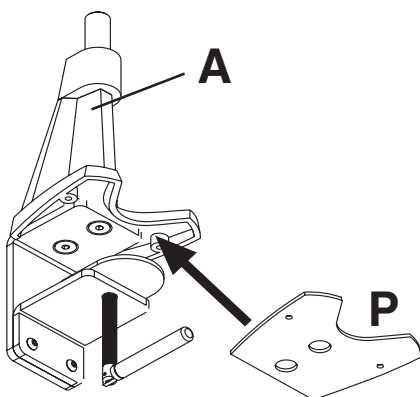

- 2 Drill a 12 mm hole through the desk. Attach base cushion (P) to desk base assembly (A) and place directly on top of the bolting hole. Tighten the M8 threaded rod (R) through the bolting hole using the M4 hex wrench (T).

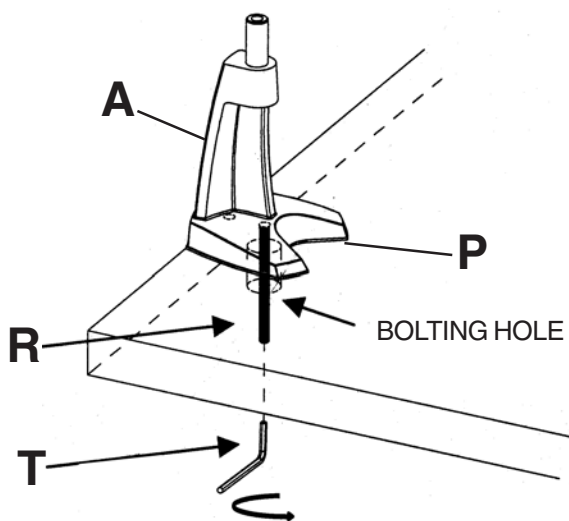

Installation with bolt option

- 1 Remove two flat head screws located underneath desk base assembly (A) using M5 hex wrench (I).

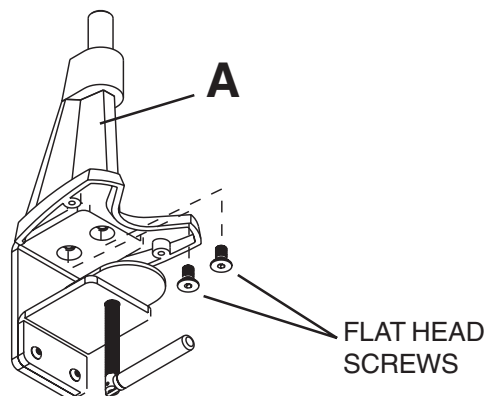

- 3 Place u-bracket (Q) and washer (F) onto the M8 threaded rod (R) and tighten with wing nut (S).

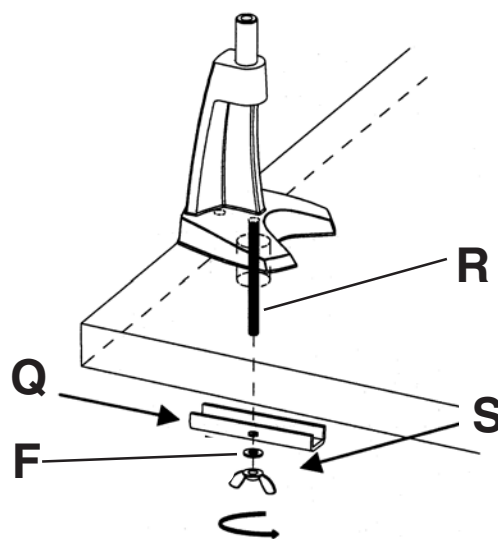

CAUTION

- Do not tighten screws with excessive force. Overtightening can cause damage to mount. Tighten screws to 40 in. • lb (4.5 N.M.) maximum torque.

Installing without extension arm (Optional)

- 4** Remove plastic cap, not shown, exposing round head cap screw. Use M5 hex wrench (I) to remove round head cap screw, M8 washer, and disk spring washer.

Place plastic spacer and arm assembly (B) onto the main shaft of the desk base (A) as shown in fig. 4.1.

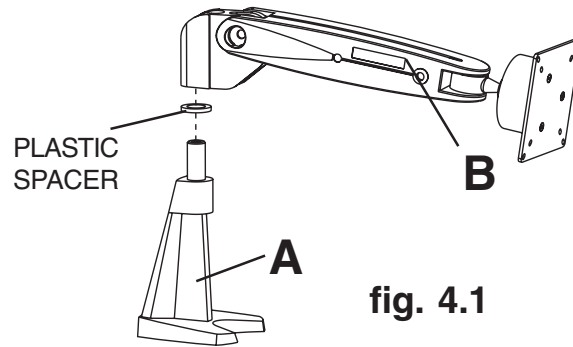
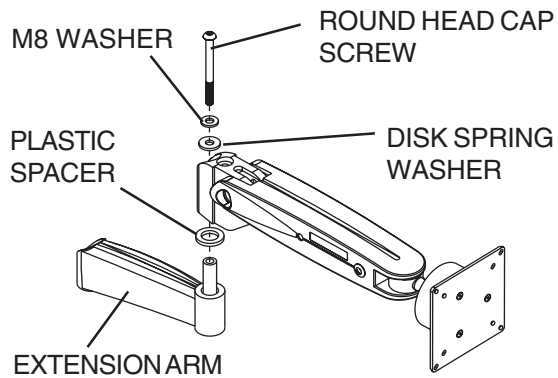

- 5** Place plastic spacer (D) and extension arm (B) onto the main shaft of the desk base (A) as shown.

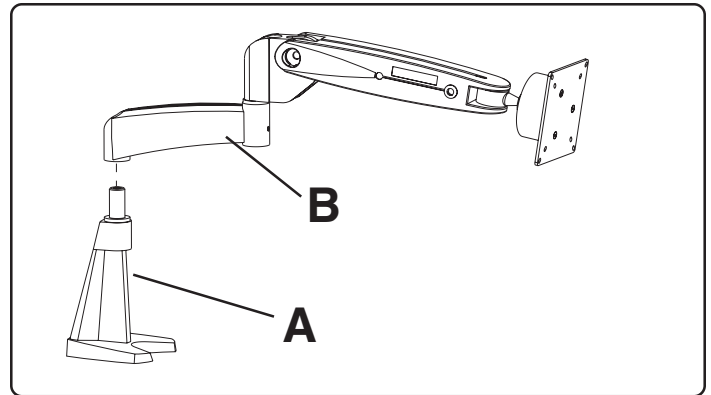
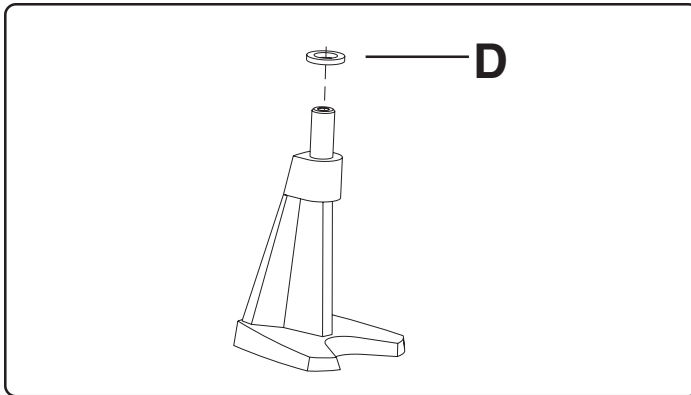

- 6** Insert round head cap screw (E) M8 washer (F) and disk spring washer (G) into extension arm (B) as shown. Tighten with the M5 hex wrench (I).

CAUTION

- Do not tighten screws with excessive force. Overtightening can cause damage to mount. Tighten screws to 40 in. • lb (4.5 N.M.) maximum torque.

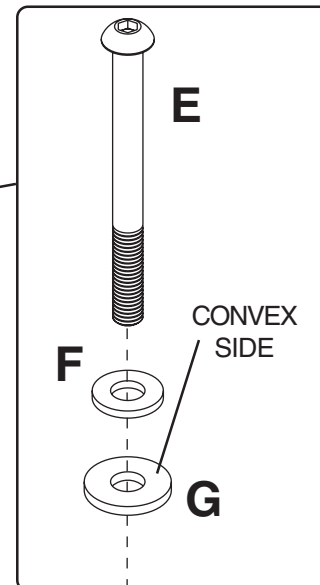
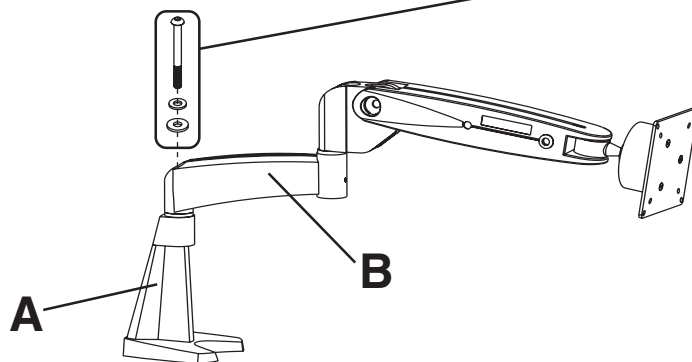

- 7 Place set screw (H) into the back of desk base (A). Tighten with the M2.5 hex wrench (J).

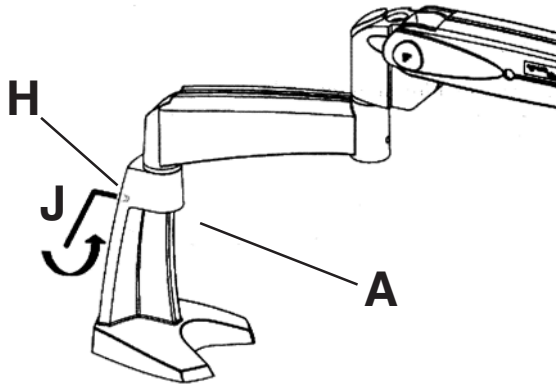

- 8 Snap plastic cap (C) into top of arm assembly (B).

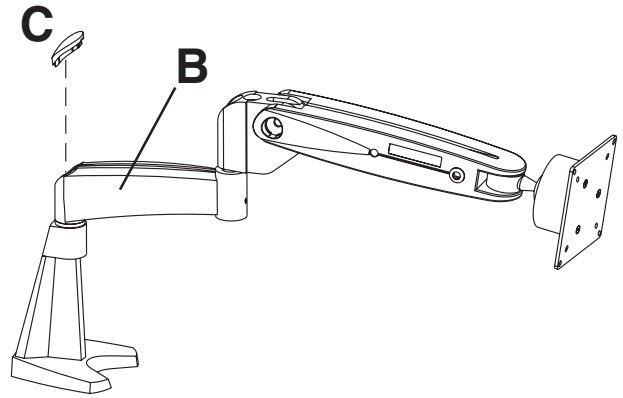

Installing monitor

- 9 Mount the LCD monitor directly to the front plate of arm assembly (B) using the M4 x 10 mm phillips screws (V) or M4 x 6mm phillips screws (U).

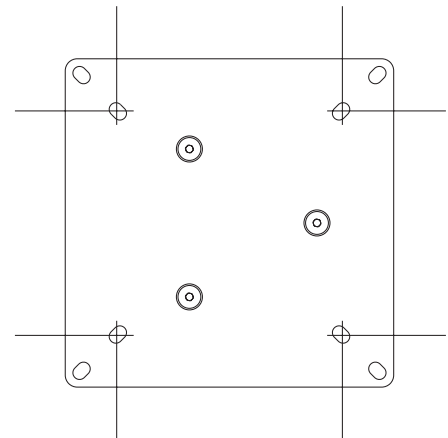
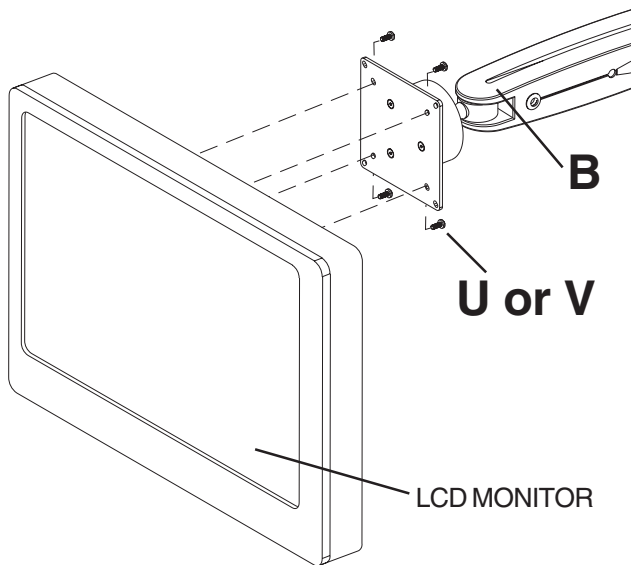

(Vesa 75 mm x 75 mm)

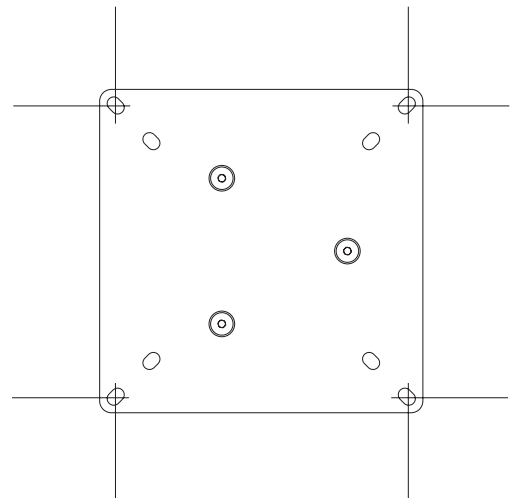

(Vesa 100 mm x 100 mm)

CAUTION

- It is important to always use the mounting screws provided by the manufacturer of the LCD monitor.

CAUTION

- Do not tighten screws with excessive force. Overtightening can cause damage to screen. Tighten screws to 40 in. • lb (4.5 N.M.) maximum torque.

Cable management

- 10** Route monitor cables through the cable mount at the bottom of arm assembly (**B**).

Note: To allow free motion of monitor and arm, leave sufficient slack in the cables.

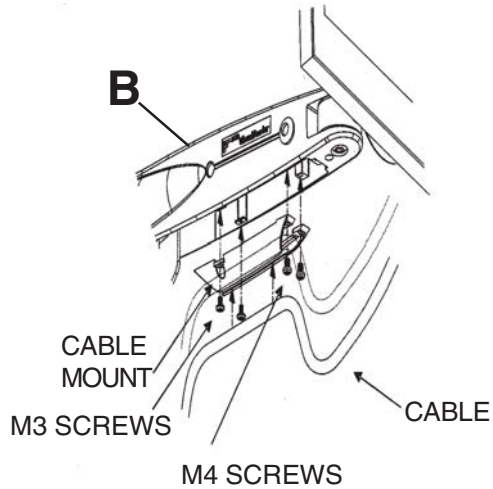

- 11** If extension arm is installed, route monitor cables through two 4" x 2.5 mm cable ties, as shown.

Note: To allow free motion of monitor and arm and extension, leave sufficient slack in the cables. Secure cables by tightening the cable tie.

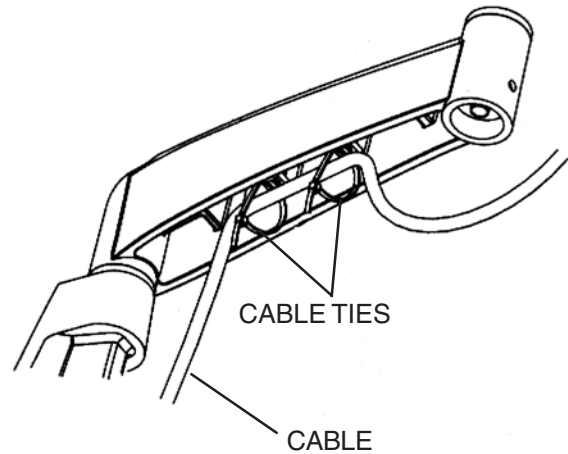

Adjustment

- 12** **Note:** Depending on the weight of the LCD monitor, adjustment may be required to the ball joint mechanism. When performing the adjustments, the arm must be in a horizontal position.

If the monitor does not hold its position or it is too tight, adjust the four tensioning screws located around the ball joint cover of arm assembly (**B**). **To tighten, adjust the tension clockwise. To loosen adjust counter clockwise.** (fig. 12.1)

Adjustment to the arm assembly may also be required if the arm tends to drift down or rise up. The adjustment screw is located at the back of the arm (**B**). Adjust using the M5 wrench (**I**). **To decrease tension, adjust the tension clockwise. To increase tension adjust counter clockwise.** (fig. 12.2)

CAUTION

- To prevent damage, remove hex wrench before releasing the arm from the horizontal position.

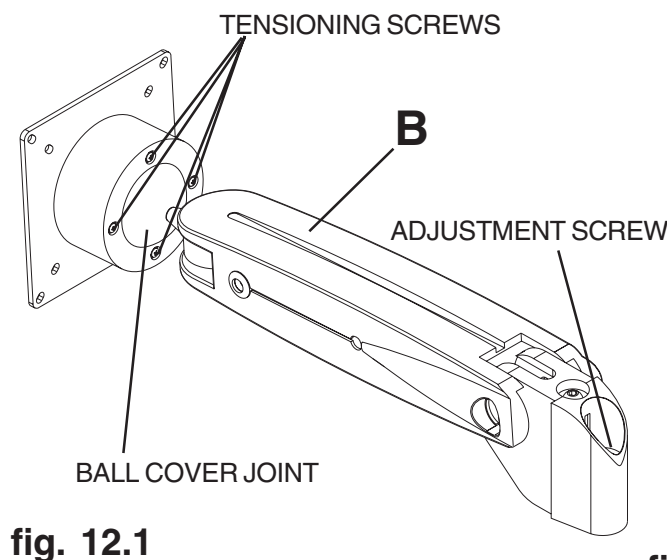
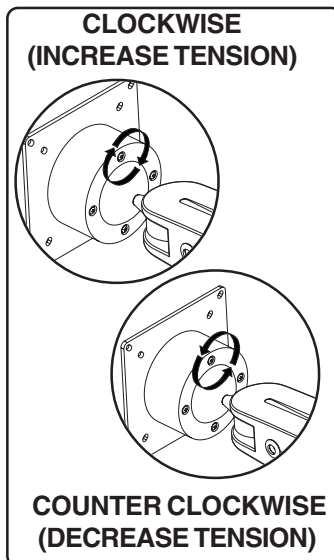

fig. 12.1

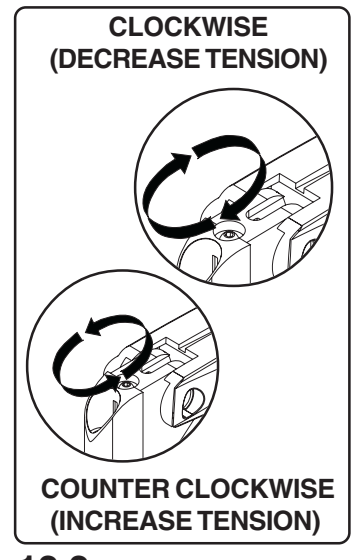

fig. 12.2